



**GENERAL COMMENTS**

In the 2013 Systems Engineering examination a number of students completed all of the questions involving formulas well, but had trouble with the design and interpretation of diagrams; other students were comfortable with the design and interpretation of diagrams, but had trouble with the formulas. This year, there was a move towards providing a standard formula sheet. For example, if students were required to calculate  $I$  then  $V = I \times R$  was given.

Questions 6 and 18 of Section B proved to be the most difficult. Question 9 of Section B was the only question where significant figures were enforced. Both significant figures and using the correct number of decimal places is of great importance.

**SPECIFIC INFORMATION**

This report provides sample answers or an indication of what the answers may have included. Unless otherwise stated, these are not intended to be exemplary or complete responses.

The statistics in this report may be subject to rounding errors resulting in a total less than 100 per cent.

**Section A – Multiple-choice questions**

The table below indicates the percentage of students who chose each option. The correct answer is indicated by shading.

Question	%A	%B	%C	%D	Comments
1	14	6	78	2	The common name is the rack and pinion. A pinion is the specific name for the small gear.
2	2	83	2	13	
3	27	8	59	7	The critical point here was on the end of link D. Point X is the load for link D but the effort for link C.
4	13	31	25	31	Although necessary for calculations, the number of measurements in the diagram seemed to confuse some students. There is no mechanical advantage of link D. As end B is connected halfway along link C, the mechanical advantage becomes 2. As a result, the force at end B is $2 \times 100 \text{ N} = 200 \text{ N}$ .
5	22	49	25	4	Basic understanding of how levers operate was required to answer this question.
6	15	5	74	6	
7	8	10	75	7	
8	55	26	12	8	The technical name is a latch.
9	3	59	22	15	Many students destroy the fuse in a multimeter when they use the ammeter function of the multimeter in parallel with a load.
10	14	13	61	11	The rating of a battery charger is the energy input. If it is 75% efficient, its output is 1.5 A. $12 \text{ Ah}/1.5 \text{ A} = 8 \text{ hours}$
11	11	12	24	54	The position of the decimal point on the screen represents the position of the thousands place value.
12	15	19	50	15	
13	2	75	16	7	$\frac{6 \times 4}{6 + 4} = 2.4 \Omega$
14	70	14	13	3	$V = 10 \text{ V}$ $R = 5 + 15 = 20 \text{ R}$ $\frac{V}{R} = \frac{10 \text{ V}}{20 \text{ R}} = 0.5 \text{ A}$
15	2	7	8	83	
16	4	28	63	5	$\frac{N_1}{N_2} = \frac{V_1}{V_2} \quad \frac{10}{5} = \frac{V_1}{110} \quad V_1 = 220 \text{ V}$

# 2013 Examination Report



Question	%A	%B	%C	%D	Comments
17	73	4	19	4	Design must come before any fabrication.
18	6	4	1	90	Field testing is conducted to check whether the product performs to design requirements.
19	3	77	17	2	Biomass energy sources are generated from living or recently living organisms.
20	6	0	89	5	

## Section B

### Question 1

Marks	0	1	2	Average
%	15	40	45	1.3

Safety was the key word. Some correct answers were

- cover for blades
- failsafe in case a person was in the way
- weatherproof of the system.

### Questions 2a.–b.

Marks	0	1	2	Average
%	41	46	13	0.8

### Question 2a.

Successful answers needed to mention issues relating to the transport of the waste materials. Clippings would be used as mulch whether they were left on the ground or put in a green waste bin.

### Question 2b.

If the grass was to be left on the field, the design needed to incorporate a means of spreading the grass or making sure the grass did not get clogged in the lawnmower.

### Questions 3a.–3b.

Marks	0	1	2	Average
%	21	28	52	1.3

### Question 3a.

The motors worked independently. To turn left, the left-hand motor would need to slow down, or the right-hand motor would need to speed up.

### Question 3b.

One of the motors can be reversed, meaning that the turning circle of option 1 is smaller.

### Questions 4a.–b.

Marks	0	1	2	3	4	5	6	Average
%	22	6	18	15	24	9	7	2.7

### Question 4a.

The simplest solution was to use a servo. An electric motor and lead screw is another possibility. Other good designs included the use of a rack and pinion gear and hydraulics.

An electric motor driving the shaft directly was not accepted.

### Question 4b.

To be awarded full marks, a description of the input, process and output of the steering system needed to be given.

# 2013 Examination Report



## Question 5

Marks	0	1	2	Average
%	31	19	50	1.2

Speed =  $\frac{\text{distance}}{\text{time}}$  1 m travelled in 0.5 seconds. Speed =  $\frac{1}{0.5} = 2\text{ms}^{-1}$

## Question 6a.–e.

Marks	0	1	2	3	4	5	6	7	Average
%	19	18	27	21	11	2	1	1	2

Many students struggled with the latter part of this question.

### Question 6a.

$2 \times 25 = 50$  rps (rpm was not accepted)

### Question 6b.

$\frac{250 \text{ mm}}{25} = 10 \text{ mm}$

### Question 6c.

A pulley uses the friction between itself and the belt. The smaller the pulley, the less friction there is.

### Question 6d.

Torque = force  $\times$  distance. The transposition of this formula to  $\text{force} = \frac{\text{torque}}{\text{distance}}$  caused problems for students in determining the correct calculation.

$\text{force} = \frac{75}{0.125} = 600 \text{ N}$

### Question 6e.

The application of the torque formula is exactly the same here as in Question 6d., except the distance becomes the radius of the wheel.  $\text{radius} = \frac{c}{2\pi} = \frac{1}{2\pi} = 0.16$

$\text{force} = \frac{75}{0.16} = 472 \text{ N}$

## Question 7a.–b.

Marks	0	1	2	3	4	Average
%	21	31	11	18	19	1.9

### Question 7a.

	Diameter of pulley (mm)
pulley A	150 mm
pulley B	30 mm
driven pulley	150 mm

As a ratio of 25:1 was required, compound pulleys of 5:1 and 5:1 can be used.

### Question 7b.

One possible solution is including a slot for the compound pulley to slide along.

# 2013 Examination Report



## Question 8a.–b.

Marks	0	1	2	Average
%	56	24	20	0.7

### Question 8a.

Option B is the only design that will raise the main body of the lawnmower.

### Question 8b.

Options A and C will force the main body of the lawn mower down instead of up.

## Question 9

Marks	0	1	2	3	Average
%	44	15	35	5	1

$Force = pressure \times area$  needed to be transposed to  $pressure = \frac{force}{area}$

Hence,  $pressure = \frac{60.0 N}{1.00 \times 10^{-3}} = 60.0 kPa$ .

## Question 10

Marks	0	1	2	3	Average
%	26	20	23	31	1.6

Students needed to demonstrate that they knew how the pump operated. Correct answers had to mention how the valves worked.

## Question 11a.–b.

Marks	0	1	2	3	Average
%	50	31	14	6	0.8

### Question 11a.

There are only two states.

### Question 11b.

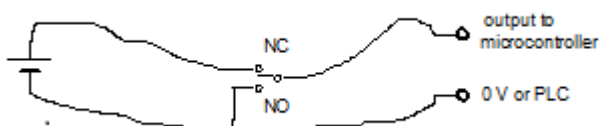

## Question 12a.–d.

Marks	0	1	2	3	4	Average
%	11	18	23	27	21	2.3

### Question 12a.

10 fixed capacitors

### Question 12b.

To store electric charge

### Question 12c.

12 V

### Question 12d.

Orange, white, orange, gold

# 2013 Examination Report



## Question 13a.–b.

Marks	0	1	2	3	4	Average
%	33	15	23	11	17	1.6

### Question 13a.

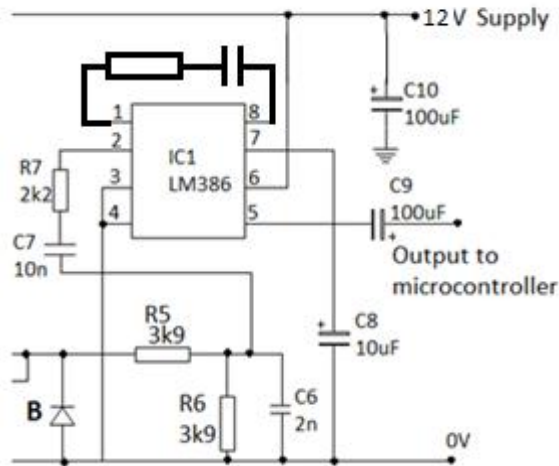

### Question 13b.

$$I = v/r = 1.2/3900 = 3.1 \text{ mA}$$

## Question 14a.–b.

Marks	0	1	2	Average
%	10	55	35	1.3

### Question 14a.

200 mV

### Question 14b.

An accurate distance to the wires could be used, rather than simply having an on/off switch.

## Questions 15a.–e.

Marks	0	1	2	3	4	5	6	7	8	9	Average
%	10	12	15	16	14	11	10	8	5	1	3.6

### Question 15a.

Closed-loop

### Question 15b.

Sensor 1 will produce a higher voltage output. Sensor 2 will produce a lower voltage output.

### Question 15c.

The smaller the output from the sensor, the slower the speed of the associated motor. The larger the output voltage, the faster the speed. So, if the output from sensor 1 is reduced, the speed of motor 1 is reduced, and if the output from the sensor is increased, the speed is increased.

### Question 15d.

Pins 3, 5 and 6 all have an analog to digital converter (ADC). You could also connect to pin 4, but it would not be as effective.

As it was not specified that the metal detector required a supply voltage, pins 1 and 8 were also accepted, but were not required.

# 2013 Examination Report



### Question 15e.

All pins that could be used as an output were required (out 0, out 1, out 2, out 4) – pins 3, 5, 6 and 7 of the Integrated Circuit (IC).

### Questions 16a.–c.

Marks	0	1	2	3	Average
%	26	25	25	24	1.5

### Question 16a.

NPN transistor

### Question 16b.

In this circuit the transistor acts as a switch.

### Question 16c.

The required answer, and the answer most students gave, was an exclusive OR gate. Technically, a combination of other gates could also be used, and were accepted.

### Question 17a.–c.

Marks	0	1	2	3	4	Average
%	40	14	24	9	12	1.4

### Question 17a.

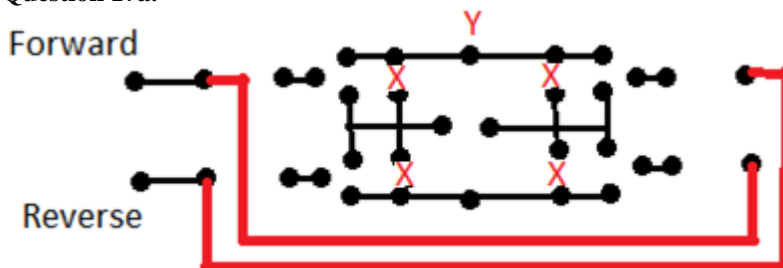

### Question 17b.

See diagram above for X positions. Any of these four positions were correct.

### Question 17c.

See diagram above for Y position.

### Question 18a.–c.

Marks	0	1	2	3	4	5	Average
%	61	20	9	5	2	3	0.8

### Question 18a.

200 W is the output of the panels.  $efficiency = \frac{output\ energy}{input\ energy} \times 100\%$

$$25 = \frac{200\ W}{input\ energy} \times 100\%. \quad \text{So input energy} = \frac{200}{0.25} = 800\ W.$$

Once again, the need to manipulate the formula caused problems.

### Question 18b.

Many students used the result from Question 18a. to work out the answer, resulting in an incorrect answer. The output energy is 200 W and the sun shines for an average of 4 hours a day.  $200\ W \times 4\ \text{hours}$  gives 800 Wh

### Question 18c.

The lawnmower needs  $2\ \text{h} \times 1.5\ \text{kW} = 3.0\ \text{kWh}$  to mow the lawns each week. The energy produced was  $800\ \text{Wh} \times 7\ (\text{days}) = 5.6\ \text{kWh}$ . This should be more than enough energy to power the lawnmower.

# 2013 Examination Report



## Question 19a.–b.

<b>Marks</b>	<b>0</b>	<b>1</b>	<b>2</b>	<b>Average</b>
<b>%</b>	6	20	75	

## Question 19a.

The correct answer was 1.30 pm. Any time between 1 and 2 pm was accepted.

## Question 19b.

The most common answer given was a tree shading the panels.

## Question 19ci.–ii.

<b>Marks</b>	<b>0</b>	<b>1</b>	<b>2</b>	<b>3</b>	<b>Average</b>
<b>%</b>	19	13	45	23	

The graph for Question 19ci. needed to show a lower peak in the production of electricity. Justifications given in Question 19cii. needed to explain that this was due to the sun shining at a lower angle and for a shorter amount of time during winter.

## Question 20

<b>Marks</b>	<b>0</b>	<b>1</b>	<b>2</b>	<b>3</b>	<b>Average</b>
<b>%</b>	8	35	26	31	

In order to gain full marks, the Systems Engineering Process must have been followed. (Note: the question did not list all of the possible processes.) Simulation must occur before construction. The construction of the frame should also occur before mounting of subsystems.

## Question 21

<b>Marks</b>	<b>0</b>	<b>1</b>	<b>2</b>	<b>3</b>	<b>4</b>	<b>5</b>	<b>Average</b>
<b>%</b>	12	9	18	29	23	9	

This question was well answered. A key word in the question was ‘discuss’. Just a list of advantages and disadvantages was not enough to receive high marks. The other key word was ‘implementing’. The question asked for the advantages and disadvantages of implementing the autonomous car, not just the advantages and disadvantages of the car itself.