



Victorian Certificate of Education 2008

SUPERVISOR TO ATTACH PROCESSING LABEL HERE

STUDENT NUMBER

Figures

Words

Letter

--

SYSTEMS ENGINEERING

Written examination

Friday 14 November 2008

Reading time: 9.00 am to 9.15 am (15 minutes)

Writing time: 9.15 am to 10.45 am (1 hour 30 minutes)

QUESTION AND ANSWER BOOK

Structure of book

<i>Section</i>	<i>Number of questions</i>	<i>Number of questions to be answered</i>	<i>Number of marks</i>
A	20	20	20
B	31	31	63
			Total 83

- Students are permitted to bring into the examination room: pens, pencils, highlighters, erasers, sharpeners, rulers, one scientific calculator.
- Students are NOT permitted to bring into the examination room: blank sheets of paper and/or white out liquid/tape.

Materials supplied

- Question and answer book of 24 pages including formulas on page 24.
- Answer sheet for multiple-choice questions.

Instructions

- Write your **student number** in the space provided above on this page.
- Check that your **name** and **student number** as printed on your answer sheet for multiple-choice questions are correct, **and** sign your name in the space provided to verify this.
- All calculations must show appropriate formulas and working.
- All written responses must be in English.

At the end of the examination

- Place the answer sheet for multiple-choice questions inside the front cover of this book.

Students are NOT permitted to bring mobile phones and/or any other unauthorised electronic devices into the examination room.

SECTION A – Multiple-choice questions**Instructions for Section A**

Answer **all** questions in pencil on the answer sheet provided for multiple-choice questions.

Choose the response that is **correct** for the question.

A correct answer scores 1, an incorrect answer scores 0.

Marks will **not** be deducted for incorrect answers.

No marks will be given if more than one answer is completed for any question.

A formula sheet is provided on page 24.

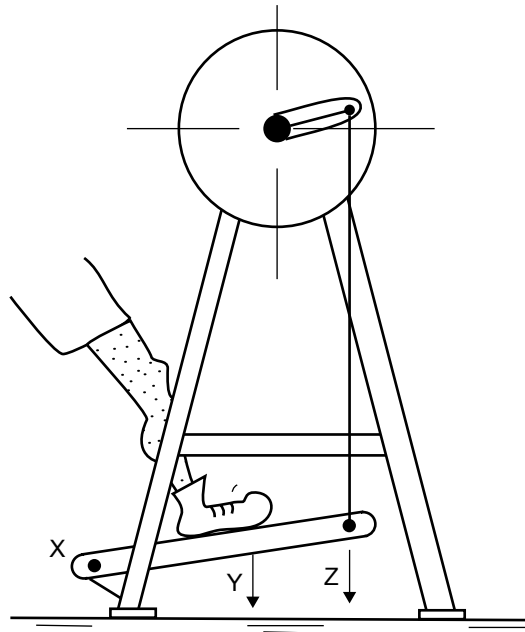
Question 1

Which of the answers below shows the correct position of the effort, load and fulcrum on the pedal attached to the grinding wheel?

- | | X | Y | Z |
|-----------|---------|---------|---------|
| A. | effort | load | fulcrum |
| B. | load | fulcrum | effort |
| C. | load | effort | fulcrum |
| D. | fulcrum | effort | load |

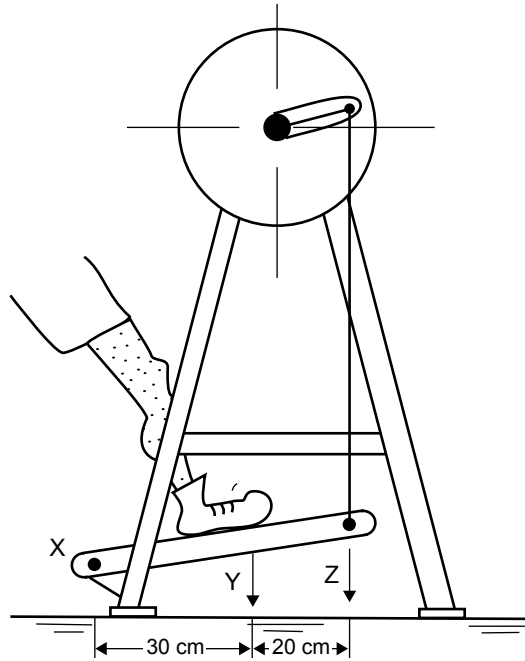
Question 2

If the effort at point Y is 60 newtons, then the force at point Z is

- A. 100 N
- B. 80 N
- C. 40 N
- D. 36 N

Question 3

The gear above is best described as a

- A. bevel gear.
- B. rack and pinion gear.
- C. worm gear.
- D. crown gear.

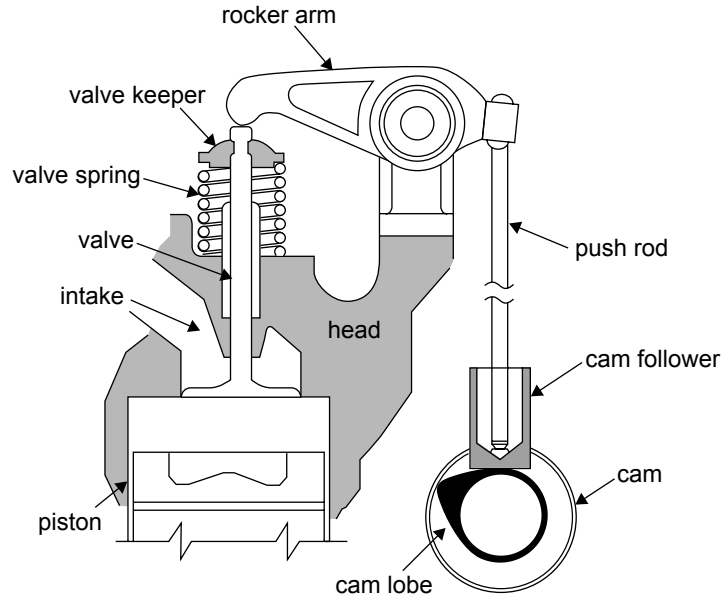
Question 4

The best description for the motion of the rocker arm in the engine is

- A. linear.
- B. rotary.
- C. forward.
- D. oscillating.

Question 5

The torsion (torque) wrench is a tool **designed** to

- A. undo the bolts in an engine.
- B. provide a longer handle to tighten nuts more effectively.
- C. give the torque in joules.
- D. tighten nuts and bolts to a specific torque.

Use the following diagram of a hydraulic pump to answer Questions 6 and 7.

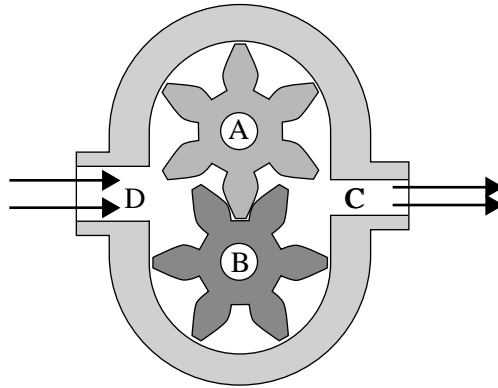

Question 6

The pump moves fluid from a tank to the outlet.

The rotors A and B have rotary motion that is

- A. clockwise for A and anticlockwise for B.
- B. clockwise for both.
- C. anticlockwise for both.
- D. anticlockwise for A and clockwise for B.

Question 7

The fluid pressures are

- A. low at point C and high at point D.
- B. high at point C and low at point D.
- C. the same at point C and point D.
- D. zero at point C and point D.

Question 8

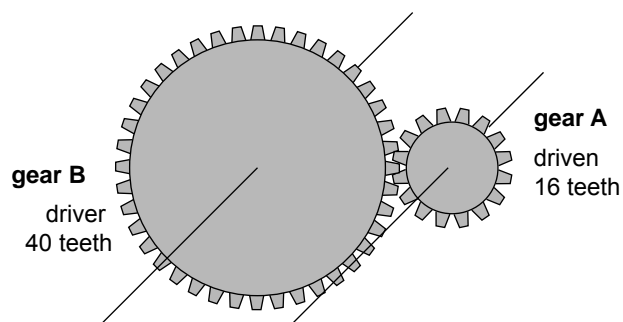

If gear A rotates at 200 rpm, gear B will rotate at

- A. 80 rpm
- B. 200 rpm
- C. 400 rpm
- D. 500 rpm

Question 9

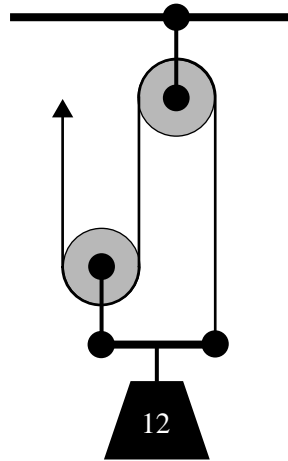

Given that the downward force is 12 newtons, what is the force required on the rope to lift the weight?

- A. 3 newtons
- B. 4 newtons
- C. 6 newtons
- D. 12 newtons

Question 10

The colour code for a 27 K, 5% tolerance resistor is

- A. red violet red gold.
- B. red violet orange gold.
- C. red violet brown gold.
- D. red violet black gold.

Question 11

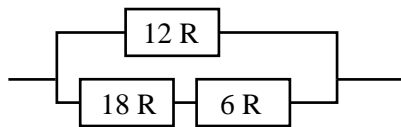

The total resistance is

- A. 6 R
- B. 8 R
- C. 9 R
- D. 12 R

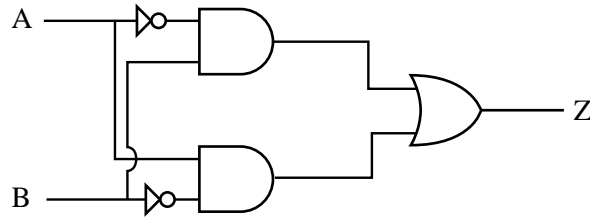
Question 12

Which of the truth tables below represents the circuit above?

A.

A	B	Z
0	0	1
0	1	1
1	0	0
1	1	0

B.

A	B	Z
0	0	0
0	1	1
1	0	1
1	1	0

C.

A	B	Z
0	0	0
0	1	0
1	0	1
1	1	1

D.

A	B	Z
0	0	1
0	1	0
1	0	0
1	1	1

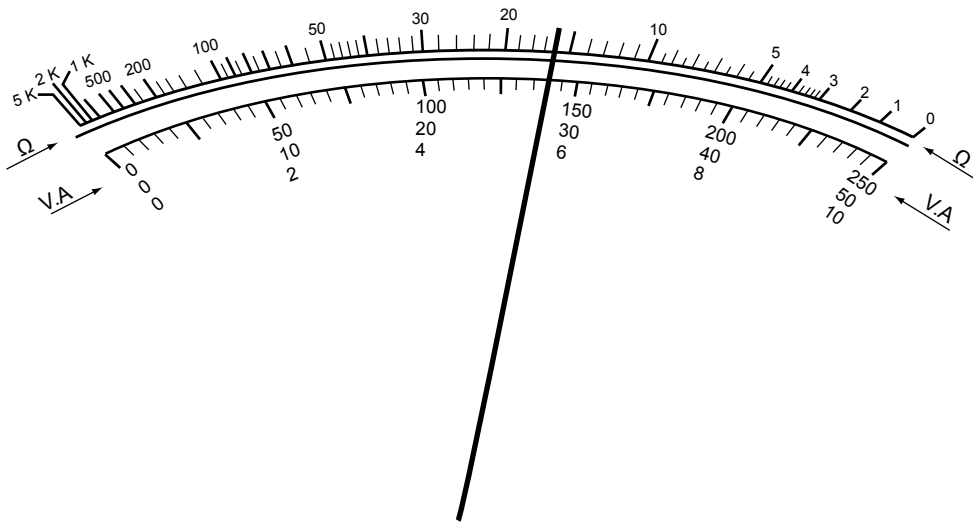
Question 13

The selector on the analog multimeter is set to direct current (DC) with a full-scale deflection of 10 A.

How much current does the reading on the meter show?

- A. 16 A
- B. 5.3 A
- C. 5.6 A
- D. 28 A

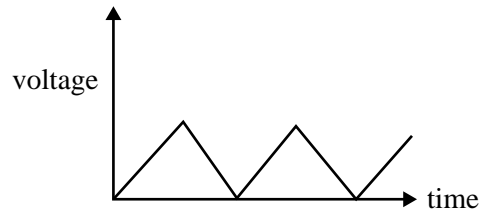
Question 14

The waveform shown in this graph is best described as

- A. alternating current.
- B. square wave current.
- C. varying direct current.
- D. digital current.

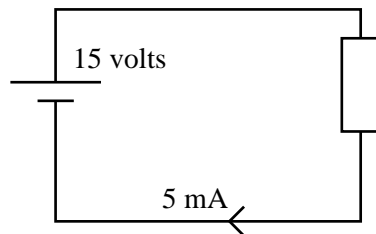
Question 15

The value of the resistor is

- A. 3Ω
- B. 75Ω
- C. 3000Ω
- D. 75000Ω

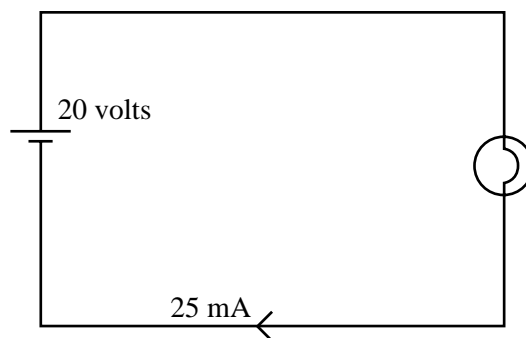
Question 16

The power output of the electric light in the circuit above is

- A. 800 mW
- B. 50 W
- C. 80 W
- D. 0.5 W

Question 17

The name of this circuit symbol is

- A. variable DC power supply.
- B. variable AC power supply.
- C. variable capacitor.
- D. variable resistor.

Question 18

When a new product (for example a new car) is designed for the market there is usually extensive field-testing carried out on the product.

The purpose of this testing is to

- A. check whether people like the product.
- B. check whether the product performs to its design requirements.
- C. check whether the product has the right range of colours.
- D. check whether the product will sell.

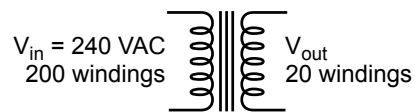
Question 19

The value of the voltage across the output windings is

- A. 24 V
- B. 240 V
- C. 12 V
- D. 2400 V

Question 20

Biofuel is best described as energy produced from

- A. water.
- B. burning wood.
- C. plant matter.
- D. crude oil.

SECTION B – Short answer questions

Instructions for Section B

Answer **all** questions in the spaces provided.
 A formula sheet is provided on page 24.

Farmer Bill wants to build a gate for his farm. He will use the following devices in the construction of a gate.

Question 1

Under each of the diagrams below, name the class of lever used in each object.

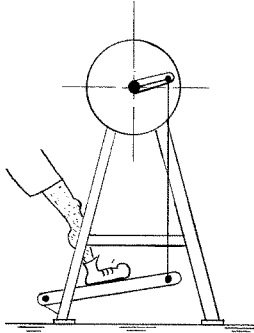

Grinding wheel

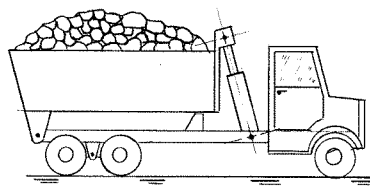

Tip truck

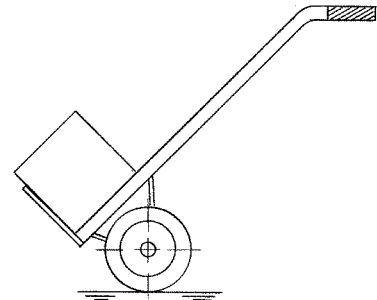

Trolley

3 marks

The gate Farmer Bill constructs is shown in Figure 1. Farmer Bill will need to drive his tractor through the gate when it is open and he would like to make a self-closing mechanism (a mechanism that closes the gate after he has passed through it) for the gate.

He will construct the mechanism from the materials he has in his shed.

He has the following materials in his shed.

- a small tool kit
- a tension spring
- a reel of fencing wire
- a pile of bricks
- nuts and bolts
- a compression spring
- 10 m of rope
- a star post
- pulley

The gate is 2 m high and 3 m wide.

The tractor is 2.6 m high.

Question 2

- a. On the diagram below, design, draw and label a self-closing mechanism from the **materials** that Farmer Bill has in his shed.

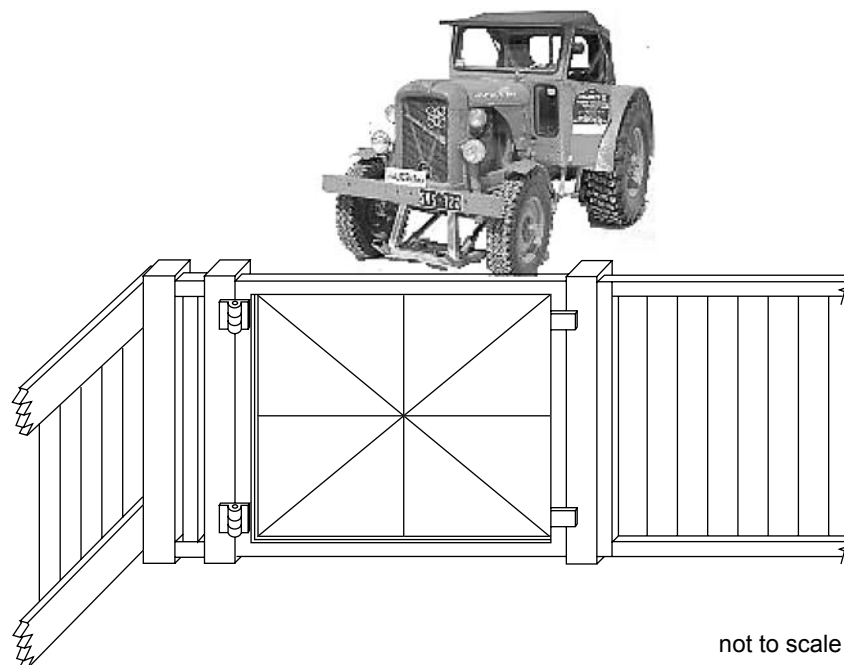

Figure 1

4 marks

- b. Give a safety problem that could occur during the construction of the self-closing mechanism.

1 mark

Farmer Bill changes his mind and decides against the self-closing mechanism. He decides to design an integrated system to open and close the gate. The integrated system includes a mechanical subsystem built on hydraulic principles. The integrated system will be operated by a radio-controlled system. The integrated system is shown in Figure 2 below.

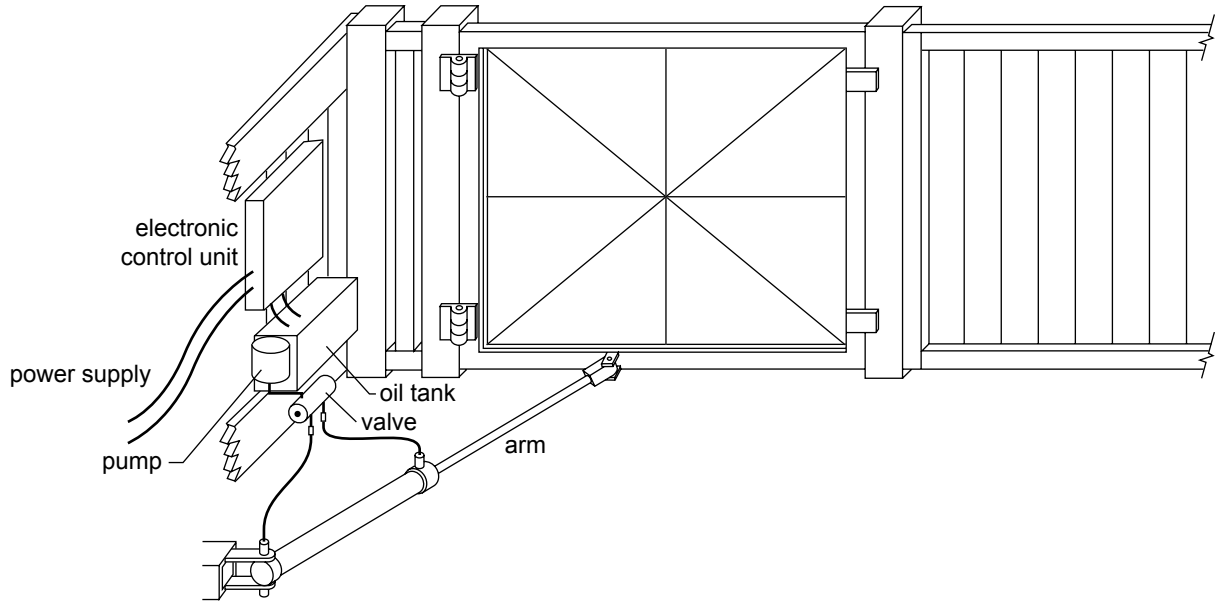
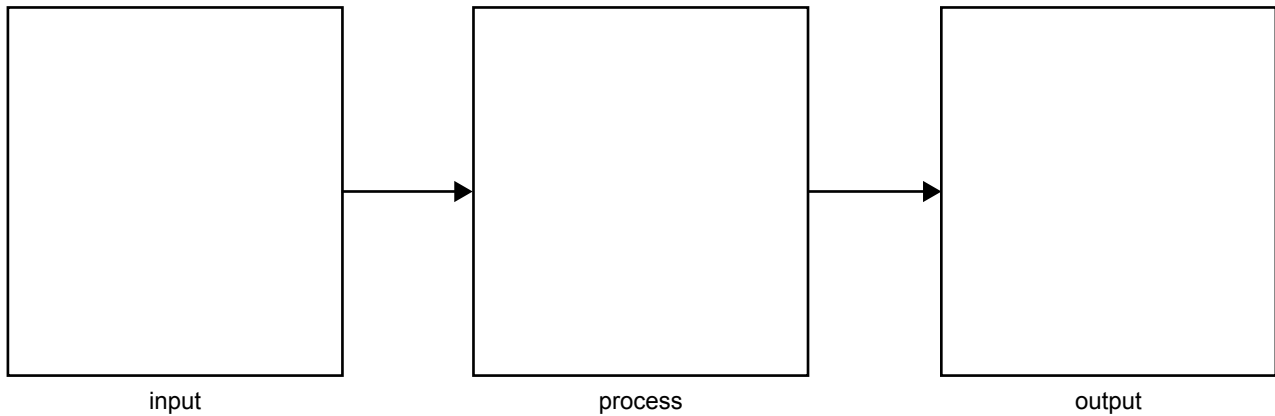

Figure 2

Question 3

Complete the systems block diagram below for the **integrated system** shown above.



3 marks

A bolt attaches the arm to the gate as shown in Figure 3.

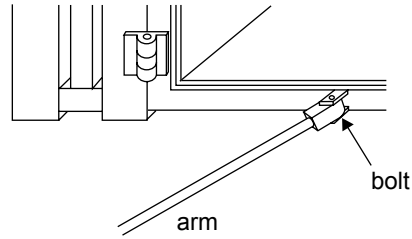

Figure 3

Question 4

- a. This bolt should not be fully tightened. Why?

1 mark

- b. Design one method to secure the nut on the bolt and use a diagram to explain it.

2 marks

A diagram of the mechanical subsystem based on hydraulic principles which Farmer Bill designed is shown in Figure 4.

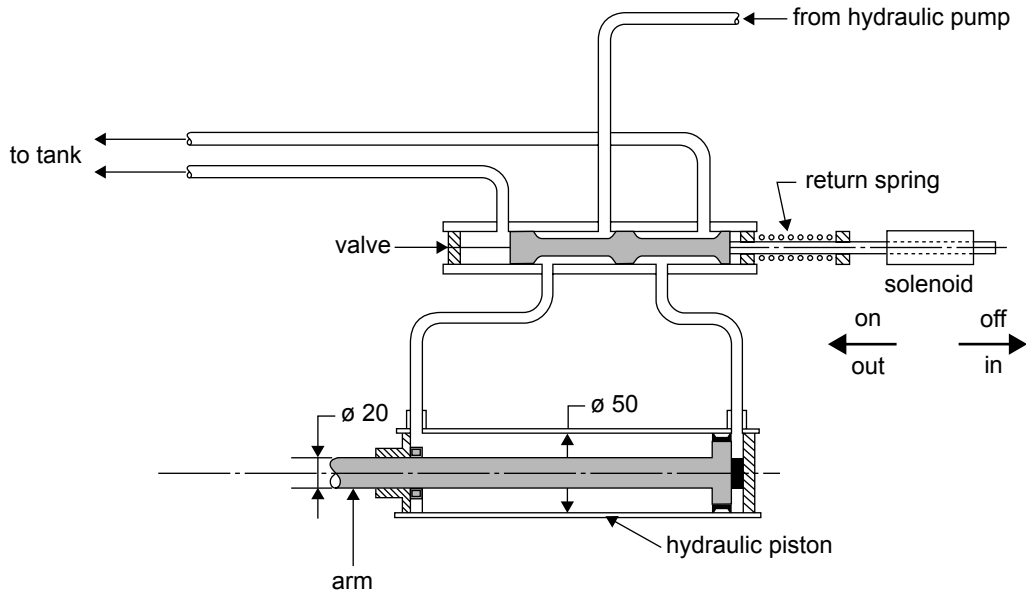

Figure 4

Question 5

On Figure 4 above, draw the flow of the fluid that is under pressure from the hydraulic pump to the hydraulic piston.

1 mark

Reverse is obtained by sliding the valve to its new position as shown in Figure 5.

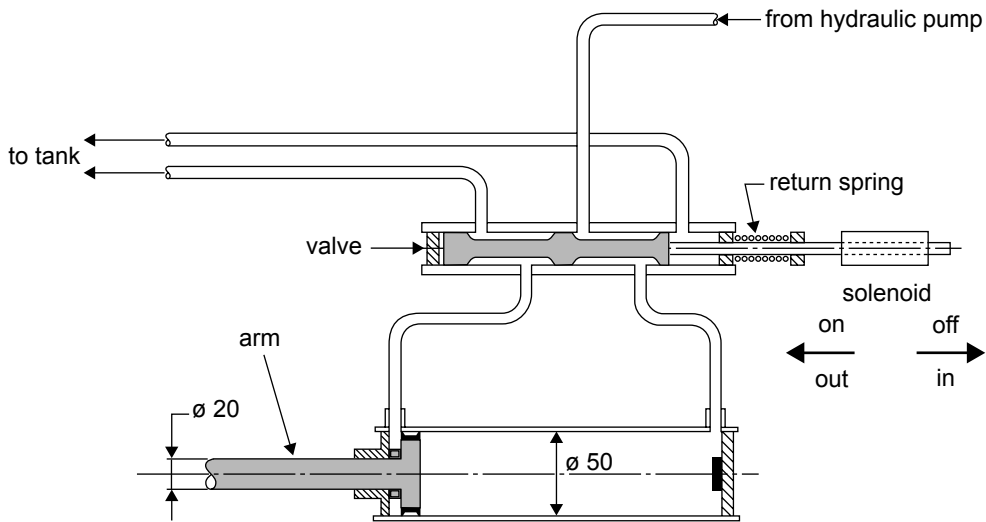

Figure 5

Question 6

On Figure 5 above, draw the flow of fluid where the fluid is under pressure with the valve in its new position.

1 mark

Figure 6 shows the piston of the arm.

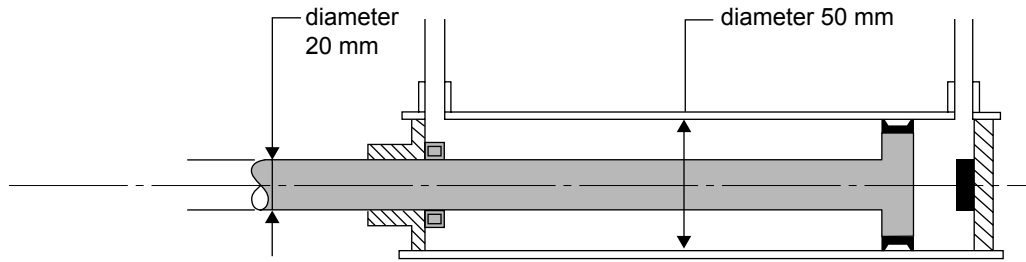

Figure 6

Question 7

Does the piston have an equal force acting on it in both directions?

1 mark

Question 8

Calculate the force on the piston, when it is moving to the right, if the pressure of the fluid is 2000 Pa. The piston is a cylinder.

You must show your working.

4 marks

Figure 7 shows the gate with the integrated system.

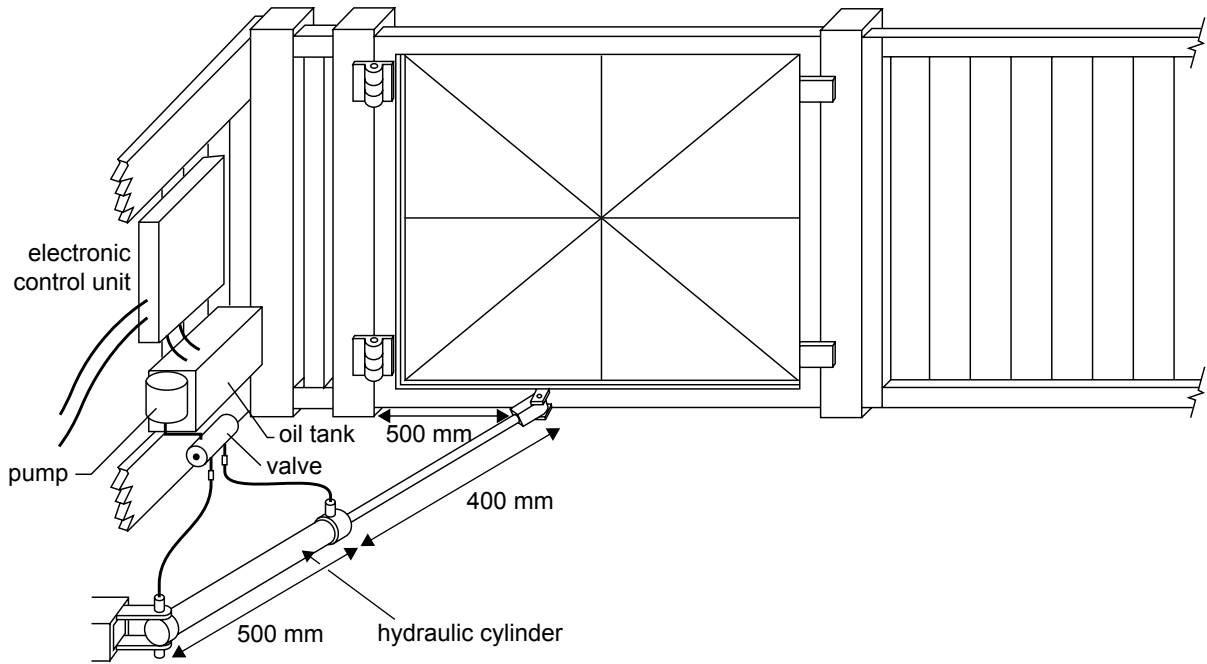

Figure 7

The shaft of the cylinder can move 400 mm. With the present equipment, the gate closes fully but it does not open fully.

Question 9

What alteration could be made, using the same hydraulic cylinder, so that the gate will open and close fully?

1 mark

An alternative design for the gate is to have it operated by an electric motor and gear mechanism as shown in Figure 8.

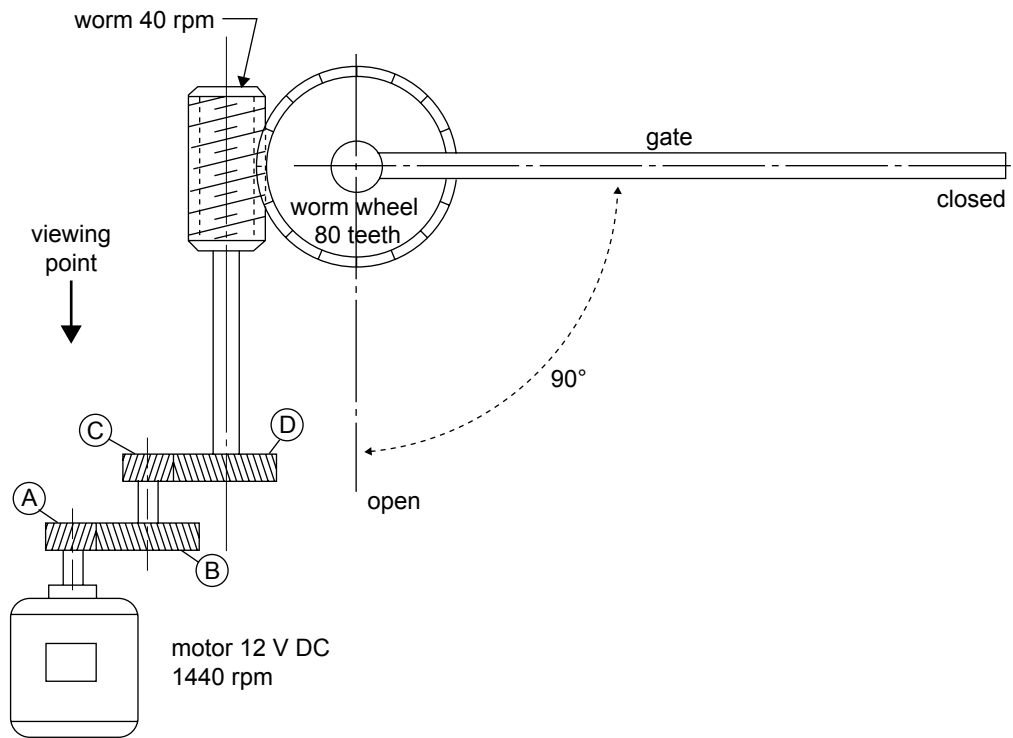

Figure 8

Farmer Bill looks at gear A and the shaft of the motor from the viewing point shown in Figure 8.

Question 10

In which direction (clockwise or anticlockwise) will the shaft of the motor turn to open the gate?

1 mark

Question 11

The motor is rotating at 1440 rpm and it needs to turn the worm gear at 40 rpm.

Identify the number of teeth on gear B and gear C.

Gear	Number of teeth
A	15
B	
C	
D	72

2 marks

The worm gear in Figure 8 above has a single start.

Question 12

The worm wheel has 80 teeth. How many turns of the worm gear will it take to move the gate to the open position?

1 mark

The worm continues to rotate at 40 rpm.

Question 13

How much time does it take the gate to move to the open position?

1 mark

The 12 V DC electric motor is designed to rotate at 1440 rpm. This needs to be tested but it is too fast to count by eye.

Question 14

Describe a realistic diagnostic test, using a stop watch, that would allow you to test the 1440 rpm rating of the motor.

1 mark

Question 15

What results do you expect from your diagnostic test?

1 mark

Farmer Bill decides that he will need a safety system that will stop the gate closing if an object is in the way of the gate.

His first idea is to have a motion sensor at point A as shown in Figure 9.

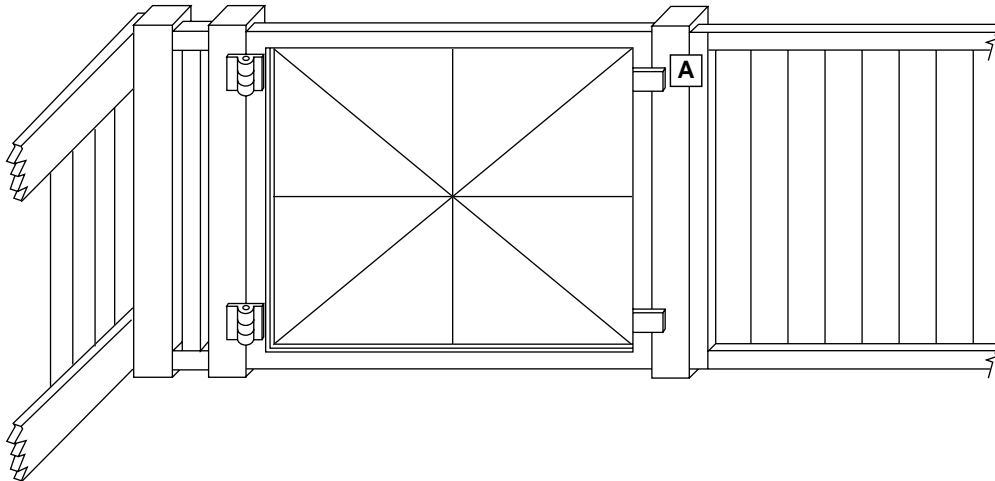

Figure 9

Question 16

Why is a motion sensor at point A not a very good idea? Give a valid reason.

1 mark

A 12 V DC motor, a 12 V DC power supply and a double pole double throw (DPDT) switch are to be connected to make a simple reversing switch.

Question 17

Explain what would happen if Farmer Bill connected the motor as shown in each of the following cases.

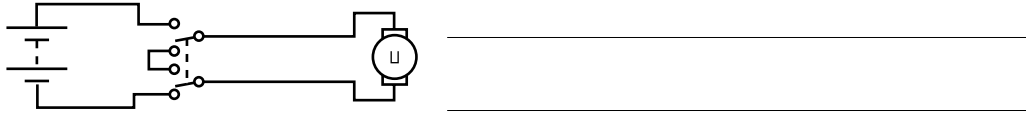

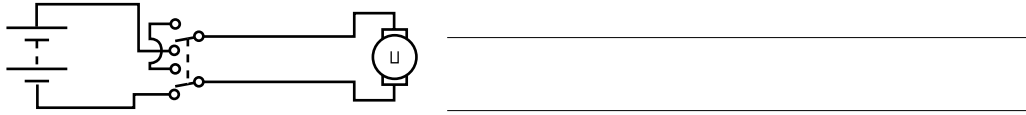

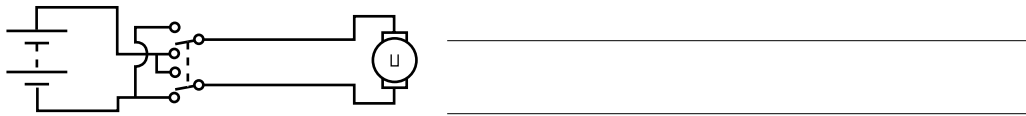

3 marks

Question 18

The electric motor is rated at 240 watts. Calculate the current through the circuit.
You must show working.

2 marks

Question 19

The power used to close the gate was measured to be 150 watts. Calculate the efficiency of the total system.
You must show working.

2 marks

If there is an object that is in the way of the gate, so that it cannot close, this can have an impact on parts of the system.

Question 20

Name one possible impact to one part of the system.

1 mark

Two pressure sensors are to be fitted on the gate, one at point B and the other at point C as shown in Figure 10. The pressure sensors are used to sense whether the gate is fully open or fully closed.

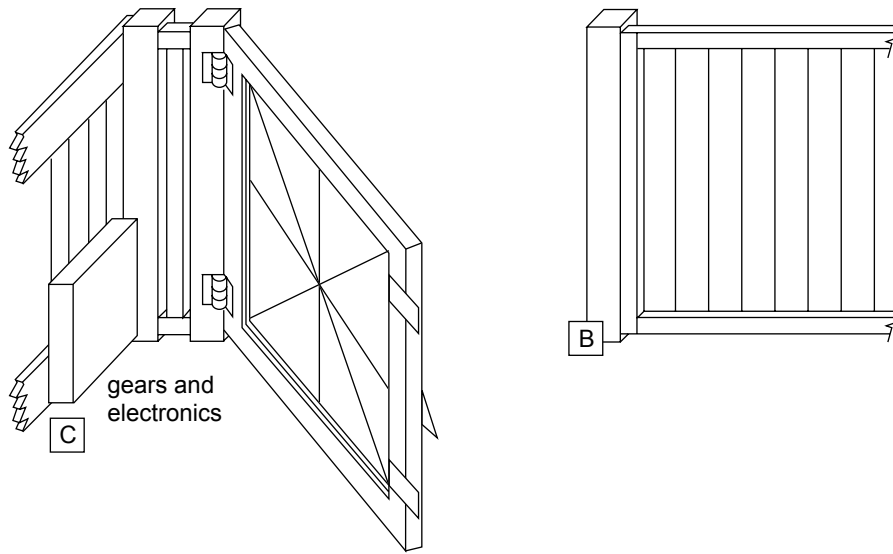
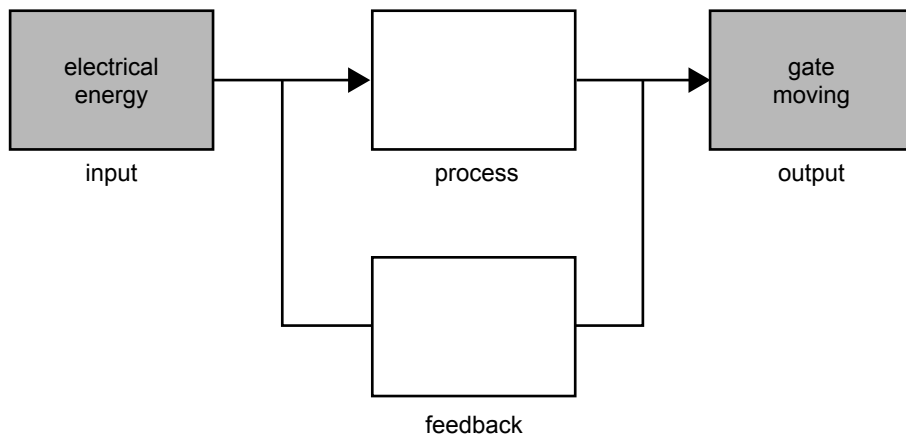

Figure 10

Question 21

Describe the process and the feedback in the systems diagram below.



2 marks

Question 22

Is this system an integrated system? Give one reason for your answer.

2 marks

Question 23

Is this system a closed-loop or open-loop system? Give one reason for your answer.

2 marks

To fit the pressure sensors, Farmer Bill will need to drill a 5 mm hole in a holding bracket. He will need to be careful when using the drill.

Question 24

Describe three different safety precautions Farmer Bill should take.

1. _____
2. _____
3. _____

3 marks

Electronic circuitry is used to convert 240 V AC to 12 V DC. This is shown in Figure 11 below.

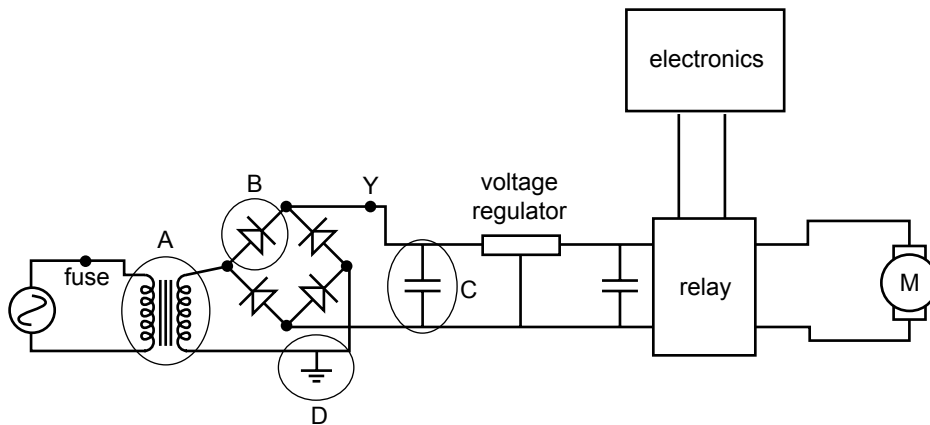

Figure 11

Question 25

Name the component represented by the circuit symbols at

point A _____

point B _____

point C _____

point D _____

4 marks

Question 26

Draw the rectified wave form at point Y on Figure 11 on the axis below.

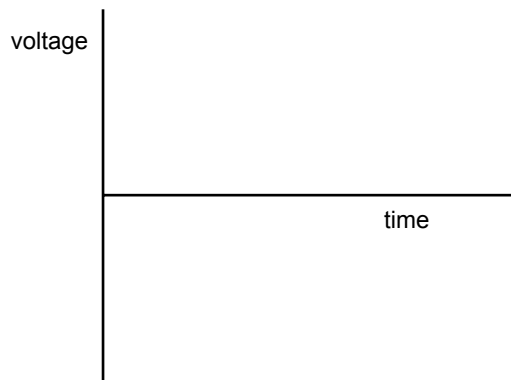

1 mark

Question 27

A voltmeter and ammeter are to be used to measure the voltage and current in the motor. On the diagram below, draw where they should be placed.

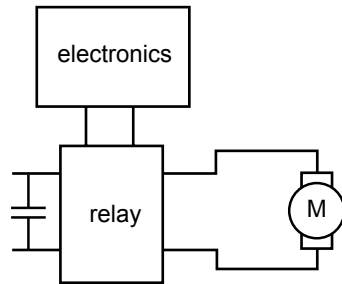

2 marks

Once the farm gate is open and anything that has gone through the gate has moved away, the gate should stay open for a short time and then close.

Farmer Bill has a circuit diagram of a timer (Figure 12a). He tries to make a circuit board (Figure 12b) from the circuit diagram but he makes a mistake. The circuit board tracks from pins 2 to 6 and the 100 nF component have been left off the printed circuit board. (In Figure 12b, the printed circuit board is viewed from bottom.)

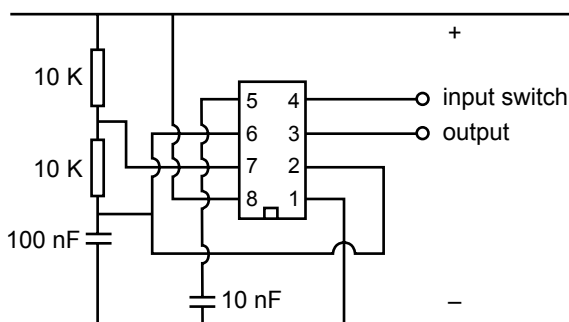

Figure 12a
circuit diagram of timer

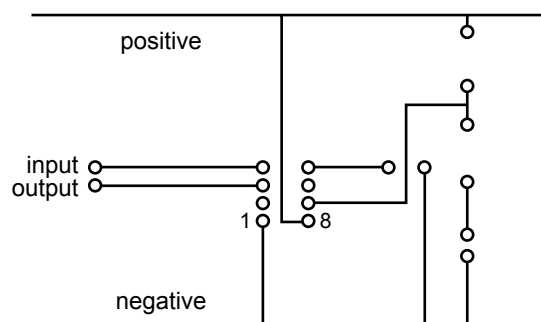

Figure 12b
circuit board of timer

Question 28

Draw the missing wires on the printed circuit board in Figure 12b.

2 marks

Farmer Bill investigates the possibility of using solar cells (photovoltaic cells), Figure 13, instead of mains electricity, to power his gate.

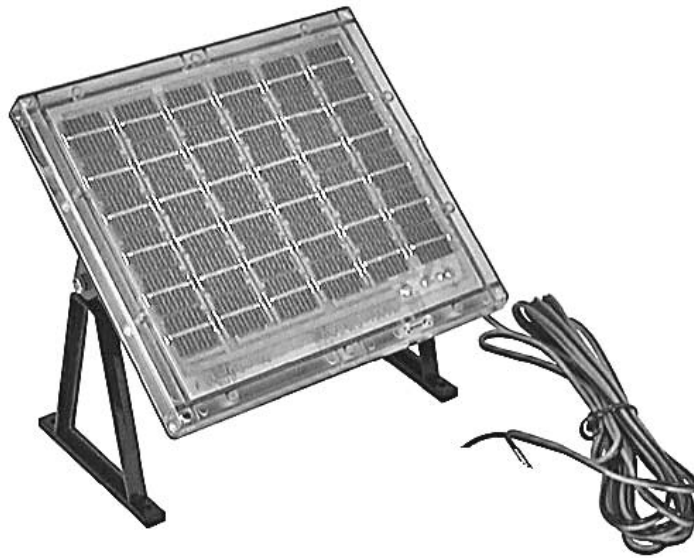
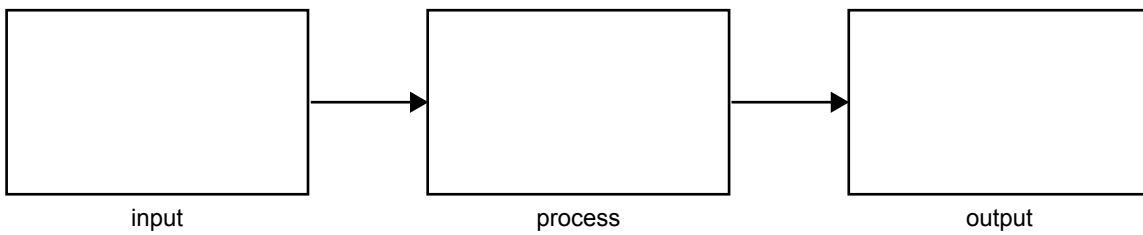

Figure 13

Question 29

In terms of energy, give the input, process and output of a solar cell.



3 marks

Question 30

Give two environmental advantages of using a solar cell instead of mains power.

2 marks

Question 31

Give two environmental advantages of using mains power instead of solar cells.

2 marks

Formula sheet

Work done = force \times distance moved

Resistance in series = $R_1 + R_2$

Gear ratio final = gear ratio 1 \times gear ratio 2

$P = V \times I$

Efficiency = $\frac{\text{output energy}}{\text{input energy}} \times 100\%$

Area of circle = πr^2 ($\pi = 3.14$)

Voltage = current \times resistance

Force = pressure \times area

Resistance in parallel = $\frac{R_1 \times R_2}{R_1 + R_2}$

$\frac{\text{gear A rpm}}{\text{gear B rpm}} = \frac{\text{number of teeth gear B}}{\text{number of teeth gear A}}$

$\frac{V_{\text{in}}}{V_{\text{out}}} = \frac{N_{\text{in}}}{N_{\text{out}}}$

Colour codes

Colour	Value
black	0
brown	1
red	2
orange	3
yellow	4
green	5
blue	6
violet	7
grey	8
white	9
gold	5%
silver	10%

END OF QUESTION AND ANSWER BOOK

