



Victorian Certificate of Education 2011

SUPERVISOR TO ATTACH PROCESSING LABEL HERE

STUDENT NUMBER

Letter

Figures										
Words										

PHYSICS

Written examination 1

Tuesday 14 June 2011

Reading time: 11.45 am to 12.00 noon (15 minutes)

Writing time: 12.00 noon to 1.30 pm (1 hour 30 minutes)

QUESTION AND ANSWER BOOK

Structure of book

<i>Section</i>	<i>Number of questions</i>	<i>Number of questions to be answered</i>	<i>Number of marks</i>
A – Core – Areas of study			
1. Motion in one and two dimensions	23	23	42
2. Electronics and photonics	12	12	24
B – Detailed studies			
1. Einstein's special relativity OR	12	12	24
2. Materials and their use in structures OR	12	12	24
3. Further electronics	12	12	24
			Total 90

- Students are permitted to bring into the examination room: pens, pencils, highlighters, erasers, sharpeners, rulers, up to two pages (one A4 sheet) of pre-written notes (typed or handwritten) and one scientific calculator.
- Students are NOT permitted to bring into the examination room: blank sheets of paper and/or white out liquid/tape.

Materials supplied

- Question and answer book of 46 pages. A formula sheet.
- Answer sheet for multiple-choice questions.

Instructions

- Write your **student number** in the space provided above on this page.
- Check that your **name** and **student number** as printed on your answer sheet for multiple-choice questions are correct, **and** sign your name in the space provided to verify this.
- Unless otherwise indicated, the diagrams in this book are **not** drawn to scale.
- All written responses must be in English.

At the end of the examination

- Place the answer sheet for multiple-choice questions inside the front cover of this book.

Students are NOT permitted to bring mobile phones and/or any other unauthorised electronic devices into the examination room.

SECTION A

Instructions for Section A

Answer **all** questions **for both** Areas of study in this section in the spaces provided. Write using black or blue pen.
 Where an answer box has a unit printed in it, give your answer in that unit.
 You should take the value of g to be 10 m s^{-2} .
 In questions where more than one mark is available, appropriate working should be shown.

Areas of study	Page
Motion in one and two dimensions	2
Electronics and photonics	18

Area of study 1 – Motion in one and two dimensions

The following information relates to Questions 1–3.

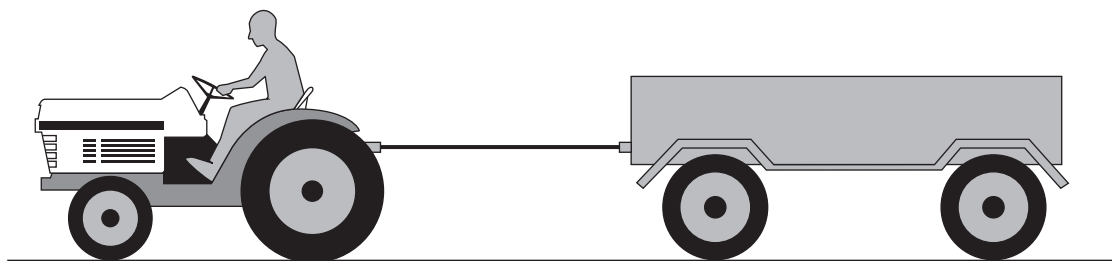

Figure 1

A tractor, including the driver, has a mass of 500 kg and is towing a trailer of mass 2000 kg as shown in Figure 1. The tractor and trailer are accelerating at 0.50 m s^{-2} . Ignore any retarding friction forces. Ignore the mass of the towing rope. The tractor and trailer start from rest.

Question 1

What is the magnitude of the net force on the system of the tractor and trailer?

N

1 mark

SECTION A – continued

NO WRITING ALLOWED IN THIS AREA

Question 2

What is the tension in the rope connecting the tractor and trailer?

 N

2 marks

Question 3

How far does the tractor move in the first 5.0 s?

 m

2 marks

SECTION A – Area of study 1 – continued
TURN OVER

NO WRITING ALLOWED IN THIS AREA

The following information relates to Questions 4–6.

A demonstration at a show involves a bike being ridden around a circular banked track.

The horizontal path the bike takes is a circle of radius 20 m, and the bike travels at a constant speed of 15 m s^{-1} .

The bike and rider have a total mass of 300 kg. Ignore retarding friction.

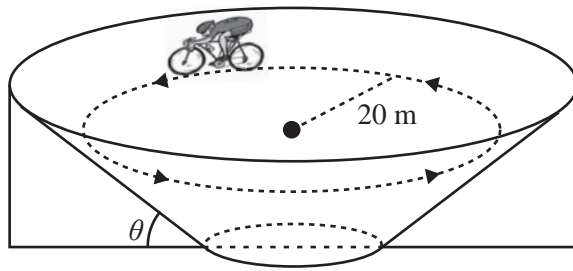

Figure 2a

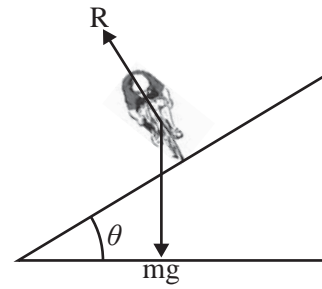

Figure 2b

Question 4

What is the magnitude of the net force on the bike and rider?

 N

1 mark

SECTION A – Area of study 1 – continued

Question 5

Figure 2b shows the only two forces on the bike and rider. On Figure 2b draw an arrow to show the direction of the net force on the bike and rider. Explain how the forces shown cause this net force.

2 marks

Question 6

What is the correct angle of the banked track, θ , to achieve this net force?



2 marks

SECTION A – Area of study 1 – continued
TURN OVER

NO WRITING ALLOWED IN THIS AREA

The following information relates to Questions 7 and 8.

Three children's toy blocks, A (0.050 kg), B (0.10 kg) and C (0.20 kg), are sitting on a table as shown in Figure 3.

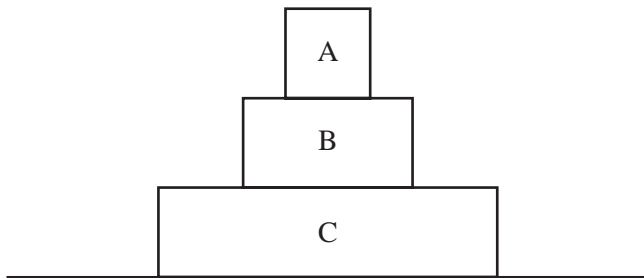

Figure 3

Question 7

What is the force by block C on block B?

Explain your answer in terms of Newton's laws.

N

2 marks

NO WRITING ALLOWED IN THIS AREA

Question 8

The table is now removed and the blocks free fall.

What is now the force by block B on block C?

Ignore air resistance.

Explain your answer.

N

2 marks

SECTION A – Area of study 1 – continued
TURN OVER

NO WRITING ALLOWED IN THIS AREA

The following information relates to Questions 9–11.

A ride at a fun fair involves a car travelling around a vertical circle of radius 15 m. The arrow indicates the direction of travel as shown in Figure 4.

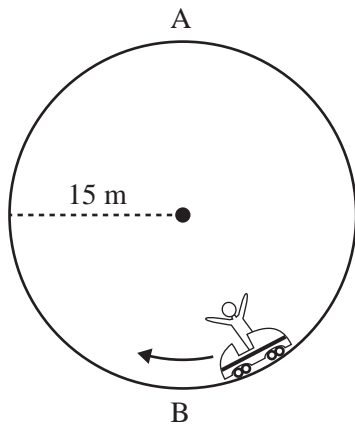

Figure 4

Question 9

What is the minimum speed that the car can have at position A if it is not to leave the rails and start to fall?

<input type="text"/>

m s⁻¹

2 marks

SECTION A – Area of study 1 – continued

NO WRITING ALLOWED IN THIS AREA

Melanie, who has a mass of 60 kg, is a passenger in the car.

Question 10

What will be Melanie's apparent weight at position A when the car is travelling at this minimum speed?

Explain your answer.

N

2 marks

As the car passes point B at the bottom of the circle, it has a speed of approximately 5.5 m s^{-1} .

Question 11

What is Melanie's apparent weight at this point?

Show your working.

N

3 marks

SECTION A – Area of study 1 – continued
TURN OVER

The following information relates to Questions 12 and 13.

Domenic fires a toy cannon, and the projectile leaves the barrel with a velocity of 24 m s^{-1} at an angle of 37° to the horizontal as shown in Figure 5. Ignore air resistance.

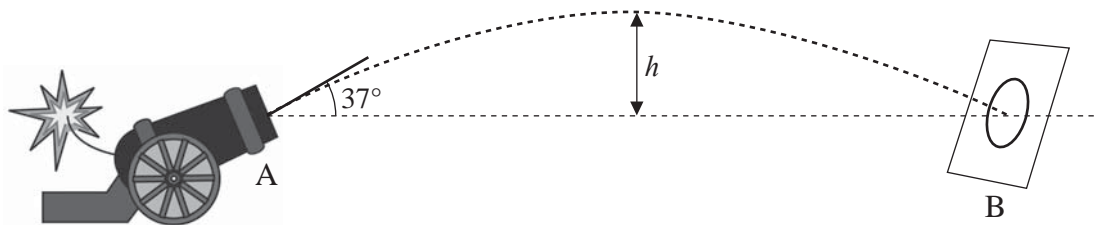

Figure 5

Question 12

How long does the projectile take to travel from point A to point B?

s

2 marks

Question 13

What is the maximum height of the trajectory (h) in Figure 5?

m

2 marks

SECTION A – Area of study 1 – continued

NO WRITING ALLOWED IN THIS AREA

The following information relates to Questions 14 and 15.

Fred is riding his sled on snow. Fred and the sled have a total mass of 60 kg. He travels downhill from A to B. The sled starts from rest.

A is a vertical height of 12.8 m above B. At B he then travels along a horizontal snowfield to point C. From A to C (on snow) there is no friction force.

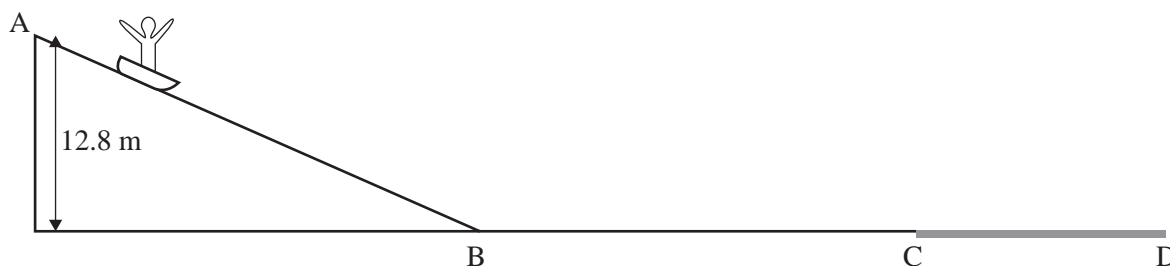

Figure 6

Question 14

What is the momentum of Fred and his sled at point C?

2 marks

At point C he runs off snow onto grass where there is now a (constant) friction force and he slows to a stop at D after a time of 6.0 s.

Question 15

What is the magnitude of the friction force as he travels from point C to point D?

2 marks

SECTION A – Area of study 1 – continued
TURN OVER

NO WRITING ALLOWED IN THIS AREA

This page is blank

NO WRITING ALLOWED IN THIS AREA

SECTION A – Area of study 1 – continued

The following information relates to Questions 16–20.

Physics students are conducting an experiment on a spring which is suspended from the ceiling. Ignore the mass of the spring.

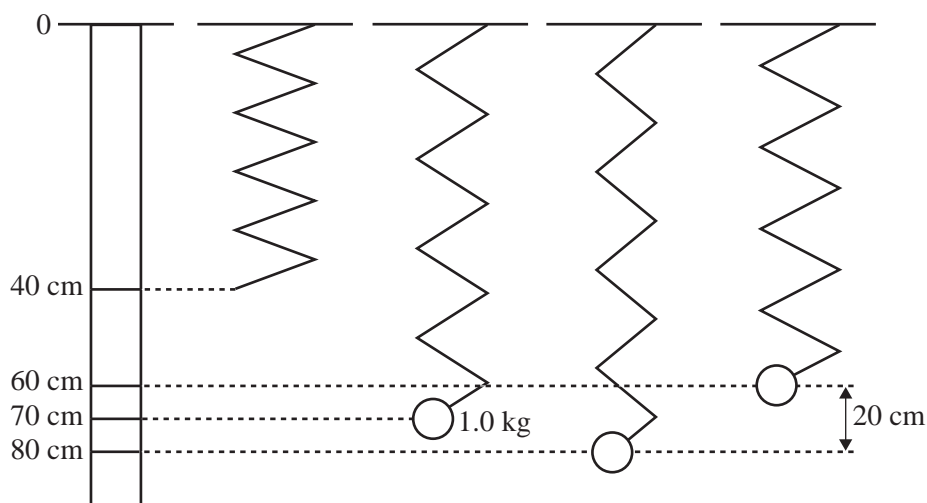

Figure 7

Without the mass attached, the spring has an unstretched length of 40 cm. A mass of 1.0 kg is then attached. When the 1.0 kg mass is attached, with the spring and mass stationary, the spring has a length of 70 cm.

Question 16

What is the spring constant, k , of the spring?

N m^{-1}

2 marks

SECTION A – Area of study 1 – continued
TURN OVER

NO WRITING ALLOWED IN THIS AREA

The spring is now pulled down a further 10 cm from 70 cm to 80 cm and released so that it oscillates. Gravitational potential energy is measured from the point at which the spring is released (80 cm on Figure 7).

Use the following graphs (A–H) in answering Questions 17–20.

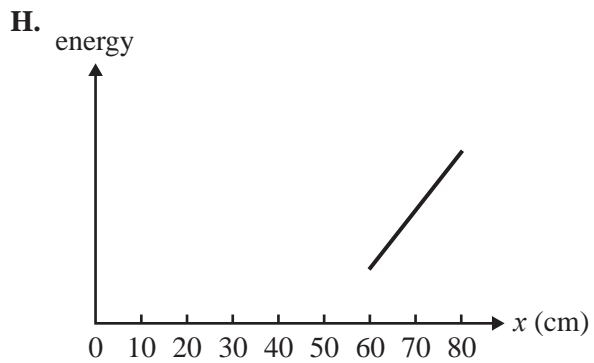
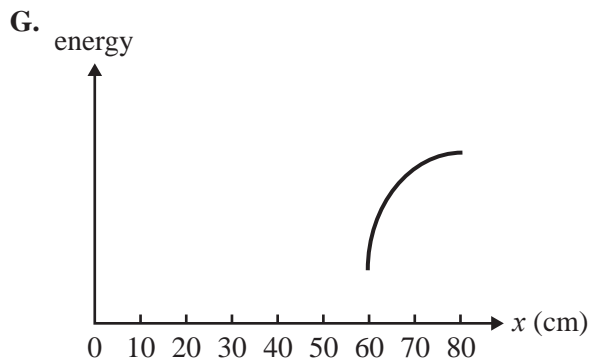
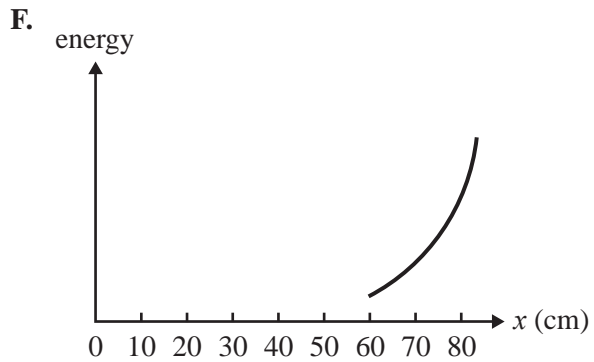
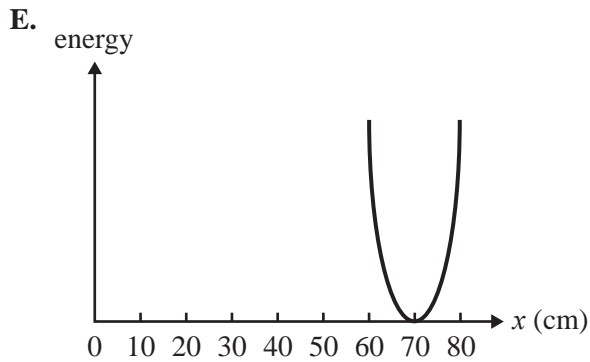
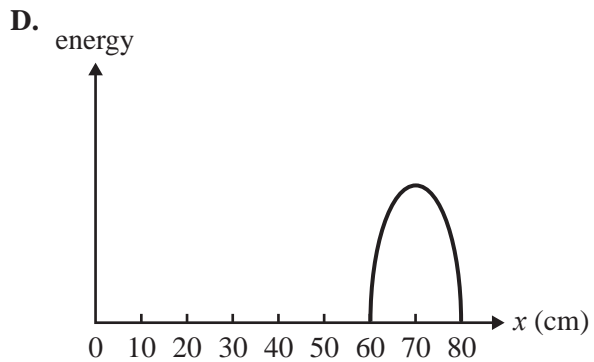
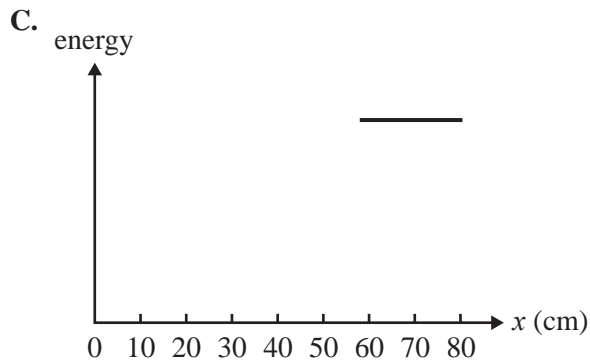
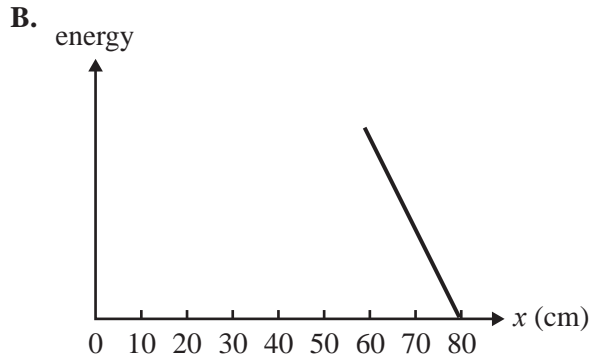
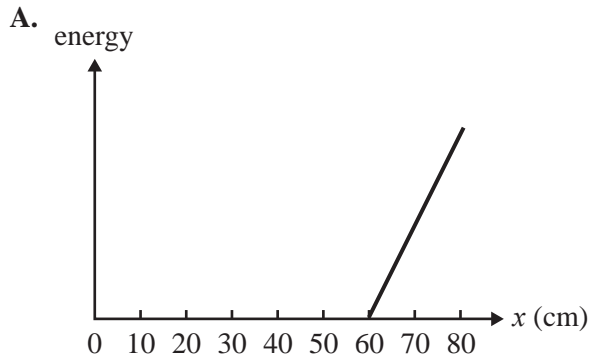

NO WRITING ALLOWED IN THIS AREA

Question 17

Which of the graphs (A–H) best shows the variation of the kinetic energy of the system plotted against the length of the stretched spring?

1 mark

Question 18

Which of the graphs (A–H) best shows the variation of the total energy of the system of spring and mass plotted against the length of the stretched spring?

1 mark

Question 19

Which of the graphs (A–H) best shows the variation of the gravitational potential energy of the system of spring and mass (measured from the lowest point as zero energy) plotted against the length of the stretched spring?

1 mark

Question 20

Which of the graphs (A–H) best shows the variation of the spring (strain) potential energy plotted against the length of the stretched spring?

Give your reasons for choosing this answer for the spring (strain) potential energy.

3 marks

SECTION A – Area of study 1 – continued
TURN OVER

NO WRITING ALLOWED IN THIS AREA

The following information relates to Questions 21–23.

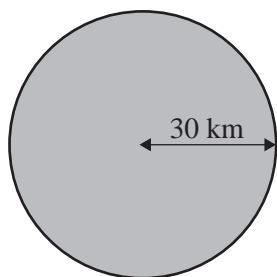

Figure 8

Assume that somewhere in space there is a small spherical planet with a radius of 30 km. By some chance a person living on this planet visits Earth. He finds that he weighs the same on Earth as he did on his home planet, even though Earth is so much larger.

Earth has a radius of 6.37×10^6 m and a mass of 5.98×10^{24} kg.

The acceleration due to gravity (g), or the gravitational field, at the surface of Earth, is approximately 10 N kg^{-1} .

The universal gravitational constant, G , = $6.67 \times 10^{-11} \text{ Nm}^2 \text{ kg}^{-2}$.

Question 21

What is the value of the gravitational field on the surface of the visitor's planet?

1 mark

Question 22

What is the mass of the visitor's planet?

Explain your answer by showing clear working.

2 marks

SECTION A – Area of study 1 – continued

NO WRITING ALLOWED IN THIS AREA

The visitor's home planet is in orbit around its own small star at a radius of orbit of 1.0×10^9 m. The star has a mass of 5.7×10^{25} kg.

Question 23

What would be the period of the orbit of the visitor's planet? Show working.

s

2 marks

END OF AREA OF STUDY 1
SECTION A – continued
TURN OVER

Area of study 2 – Electronics and photonics

The following information relates to Questions 1–4.

Four 2.0 ohm resistors (A, B, C and D) are connected as in Figure 1.

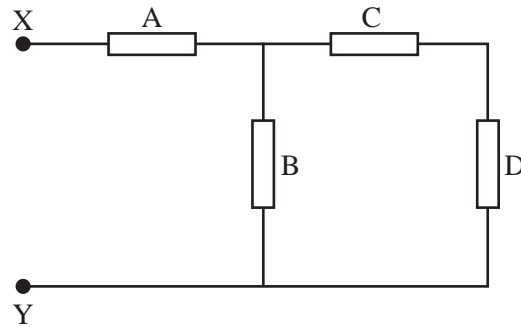

Figure 1

Question 1

Show that the total resistance of the circuit between X and Y is 3.3 ohm.

2 marks

Question 2

A 10 V battery is now connected across XY as shown in Figure 2.

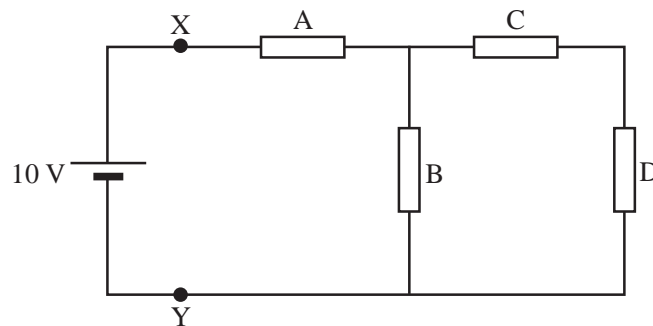

Figure 2

What is the current through resistor B?

 A

2 marks

SECTION A – Area of study 2 – continued

Question 3

What is the voltage drop (potential difference) across resistor A?

2 marks

Question 4

What is the power dissipated in resistor D?

2 marks

SECTION A – Area of study 2 – continued
TURN OVER

NO WRITING ALLOWED IN THIS AREA

The following information relates to Questions 5 and 6.

Two students have built a model house and wish to install a fan that will turn on when the temperature is **greater** than 20°C. The students used the following.

- a thermistor – The characteristics are shown in Figure 3 below.

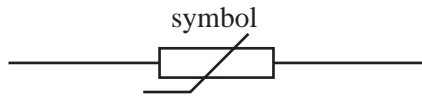

- a 6.0 V battery



- **one** only of the following resistors: 500 ohm, 1500 ohm or 4500 ohm



- a switching circuit that turns on the fan when the voltage across the input of the switching circuit is **greater** than 4.5 V

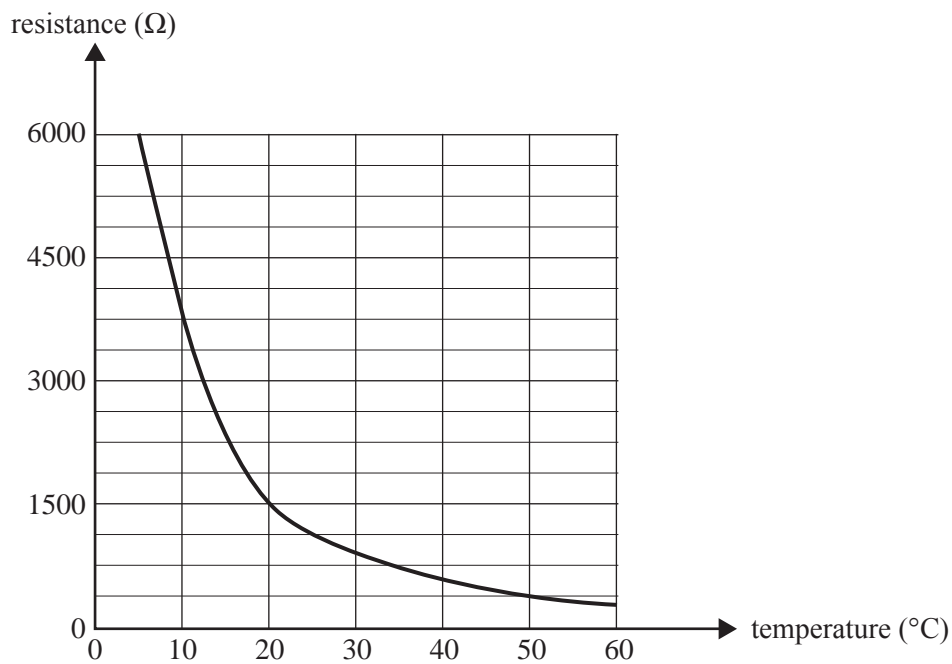
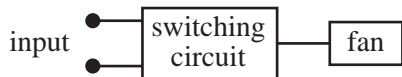

Figure 3

Question 5

What is the resistance of the thermistor when the temperature is 20°C?

Ω

1 mark

NO WRITING ALLOWED IN THIS AREA

Question 6

Using the thermistor, the 6 V battery and one resistor from the listed resistors, draw a circuit to produce a voltage greater than 4.5 V at the input of the switching circuit, and so turn the fan on, when the temperature is **greater** than 20°C. You **must** include the value of the resistor you have used on your diagram.

3 marks

SECTION A – Area of study 2 – continued
TURN OVER

NO WRITING ALLOWED IN THIS AREA

The following information relates to Questions 7 and 8.

A security system uses a light-emitting diode (LED) that emits ultraviolet light, and a photodiode that responds to this ultraviolet light.

The circuits are shown in Figure 4.

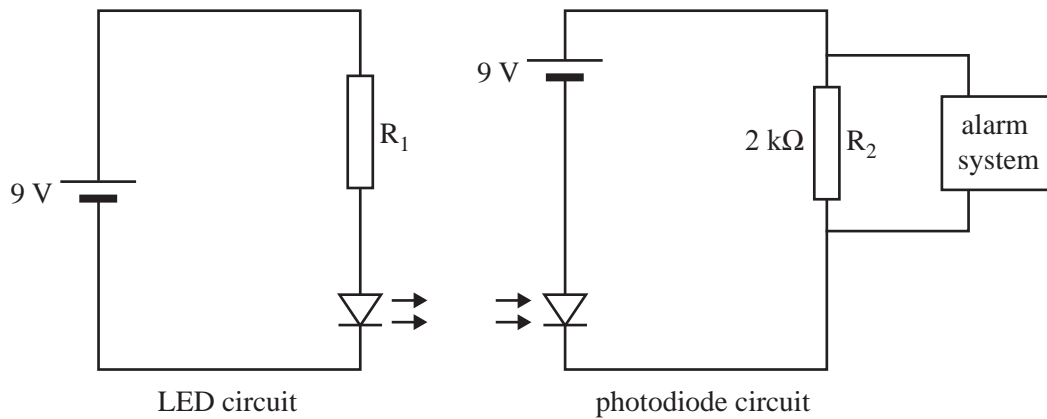

Figure 4

The current-voltage characteristics of the LED and photodiode are in Figures 5 and 6 respectively.

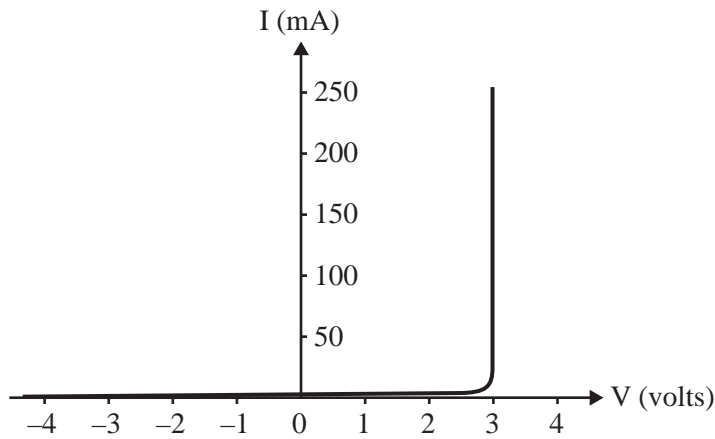

Figure 5

The LED operates at full brightness with a forward current of 150 mA.

Question 7

Use the information above to determine the maximum value of resistor R_1 for the LED to operate at full brightness.

Ω

2 marks

NO WRITING ALLOWED IN THIS AREA

Figure 6 shows the current through the photodiode (in mA) for different values of the power (in mW) of the light falling on it.

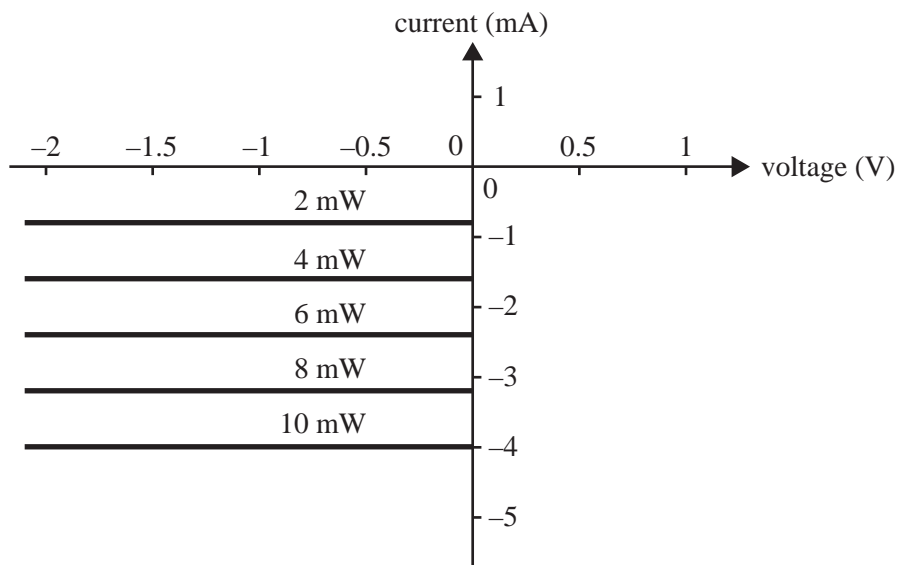

Figure 6

Question 8

Use the information in Figure 6 to determine the voltage across the $2\text{ k}\Omega$ resistor in Figure 4, when the power of the light falling on the photodiode is 10 mW .

 V

2 marks

The following information relates to Questions 9 and 10.

Two students construct a circuit to demonstrate modulation in a communication system.

The circuit is shown in Figure 7. The circuit consists of

- a battery
- an LED
- a fixed resistor, R_2 , to protect the LED from excessive current
- a variable resistor, R_1 .

The sliding contact on the variable resistor changes the current through the LED.

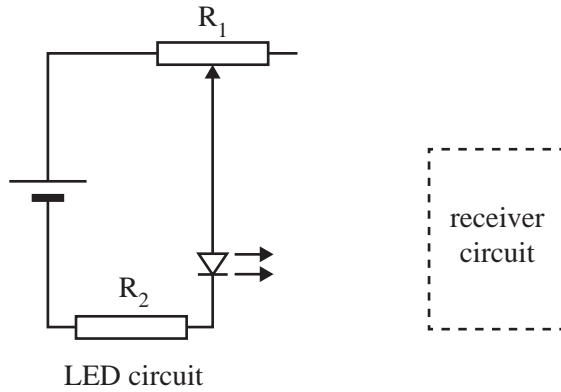

Figure 7

The sliding contact is moved to the right, then to the left, several times. The LED stays on. Figure 8 shows the amount of the resistance the variable resistor contributes to the circuit with time.

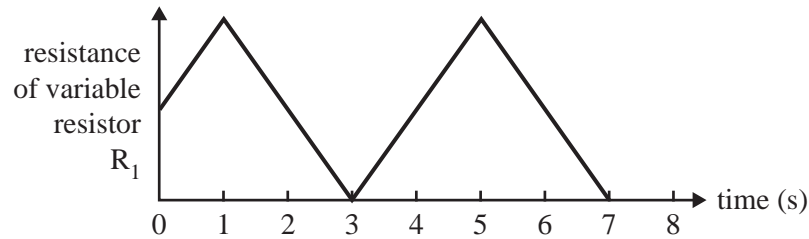
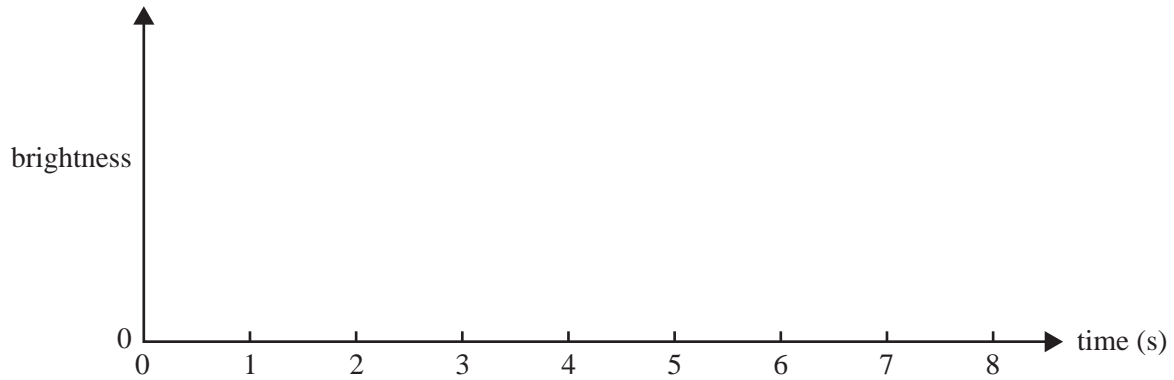

Figure 8

Question 9

On the axes below, draw the variation in the brightness of the LED with time.



2 marks

Question 10

Why is this an example of modulation? In your answer, identify the carrier wave.

2 marks

SECTION A – Area of study 2 – continued
TURN OVER

NO WRITING ALLOWED IN THIS AREA

The following information relates to Questions 11 and 12.

A voltage amplifier has the characteristics displayed in Figure 9a below.

The input signal to the voltage amplifier is displayed in Figure 9b.

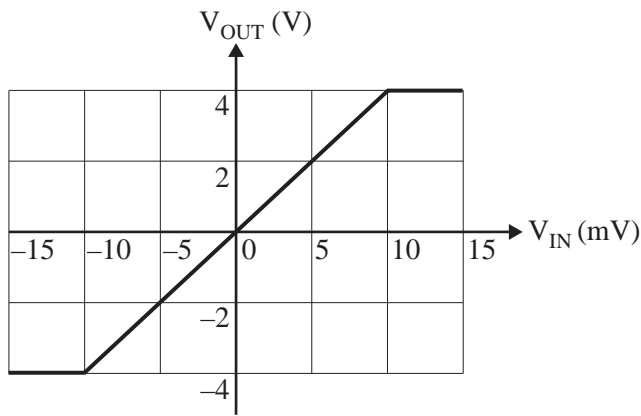

Figure 9a

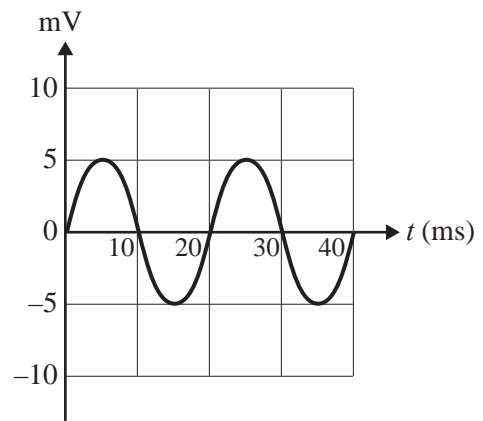
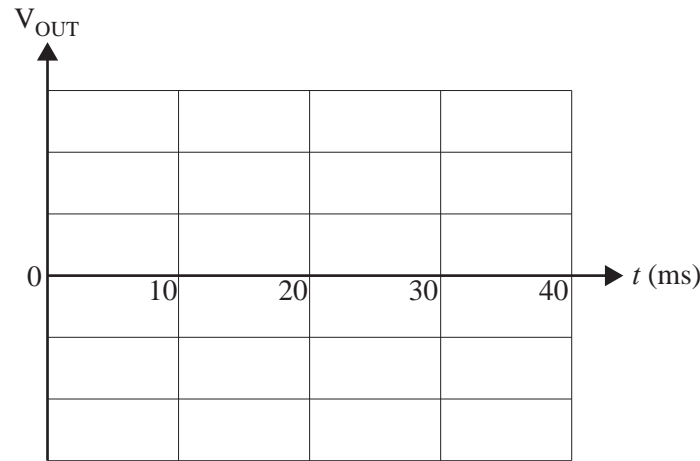

Figure 9b

Question 11

On the axes below, draw a graph of the output voltage against time. Include a scale on the voltage axis.



2 marks

Question 12

The performance of a voltage amplifier is limited by ‘clipping’.

Describe a situation using the amplifier described in Figure 9a that causes clipping to occur. What is the effect of clipping on the output voltage?

2 marks

END OF SECTION A

NO WRITING ALLOWED IN THIS AREA

SECTION B**Instructions for Section B**

Select **one** Detailed study.

Answer **all** questions from the Detailed study, in pencil, on the answer sheet provided for multiple-choice questions.

Write the name of your chosen Detailed study on the multiple-choice answer sheet **and** shade the matching box.

Choose the response that is **correct** or that **best answers** the question.

A correct answer scores 2, an incorrect answer scores 0.

Marks will **not** be deducted for incorrect answers.

No marks will be given if more than one answer is completed for any question.

You should take the value of g to be 10 m s^{-2} .

Detailed study	Page
Einstein's special relativity	28
Materials and their use in structures	32
Further electronics	38

SECTION B – continued
TURN OVER

NO WRITING ALLOWED IN THIS AREA

Detailed study 1 – Einstein’s special relativity

Question 1

An experiment is done where two protons with very high kinetic energy collide in order to try to create a single stationary ‘Higgs’ particle.

Each proton in the reaction has a kinetic energy of 1.1×10^{-6} J. No other particles are produced in the reaction and the protons will not exist after the production of the Higgs particle.

The proton rest mass is equal to 1.6726×10^{-27} kg.

Which of the following options is the best estimate of the mass of the Higgs particle?

- A. 1.2×10^{-23} kg
- B. 2.4×10^{-23} kg
- C. 3.3×10^{-27} kg
- D. 1.7×10^{-27} kg

Question 2

According to the theory of special relativity, the mass, m , of a particle, and its total energy, E , are equivalent. The relationship is

$$E = mc^2 \text{ where } m = \gamma m_0, \text{ and } \gamma = \frac{1}{\sqrt{1 - \frac{v^2}{c^2}}}$$

The amount of energy required to increase the speed of an electron from $0.18c$ to $0.19c$ is 0.004 J. By contrast, the amount of energy required to increase this electron’s speed by the same amount ($0.01c$) from $0.98c$ to $0.99c$ is 27.7 J.

Which of the following best explains why much more energy is required to produce the same change in speed for the electron when it is moving at the higher speed?

- A. The rest mass (m_0) of the electron is not a constant but depends on the speed v .
- B. The electron mass-energy is proportional to v , so it is more massive at high speed.
- C. Because $E = \frac{1}{2} mv^2$, the larger v , the more energy is required to increase it further.
- D. The total mass-energy of the electron depends on γ , which increases rapidly as v approaches c .

Question 3

When stationary, a proton has a rest mass-energy of 1.50×10^{-10} J.

A proton is accelerated from a speed with $\gamma = 1.05$ to a speed with $\gamma = 1.10$.

Which of the following is closest to the work done on the proton during its acceleration from the first speed to the second speed?

- A. 2.9×10^6 J
- B. 3.2×10^{-10} J
- C. 7.5×10^{-12} J
- D. 8.3×10^{-29} J

NO WRITING ALLOWED IN THIS AREA

Question 4

A tower is 300 m tall. A cosmic ray particle is travelling from the upper atmosphere. It is travelling perpendicular to the ground. As it speeds past the top of the tower, it measures the height of the tower to be 200 m.

Which of the following options is the best estimate of the speed of the cosmic ray?

- A. $0.56c$
- B. $0.67c$
- C. $0.75c$
- D. $0.81c$

Question 5

In deep space, a spaceship, A, passes a second spaceship, B, at a relative speed of $0.5c$. At this instant, each spaceship sends a radio message to their home base that is the same distance away from each spaceship.



Which of the following statements about the arrival time of the message at the home base is correct?

- A. Both signals will arrive at the same time.
- B. The signal from spaceship A will arrive sooner than the signal from spaceship B.
- C. The signal from spaceship A will arrive later than the signal from spaceship B.
- D. Spaceship A has a value of $\gamma = 1.15$ and this will mean that its signal will arrive approximately 15% sooner than the signal from spaceship B.

Question 6

Two cars, travelling at the same speed, are approaching a country motel from opposite directions. In Figure 1 below they are equidistant from the motel at the same time, and simultaneously sound their horns to indicate the motel of their approach.

There is a strong wind blowing from the left, as shown. Relative to the ground, the cars are travelling slightly faster than the speed of the wind.

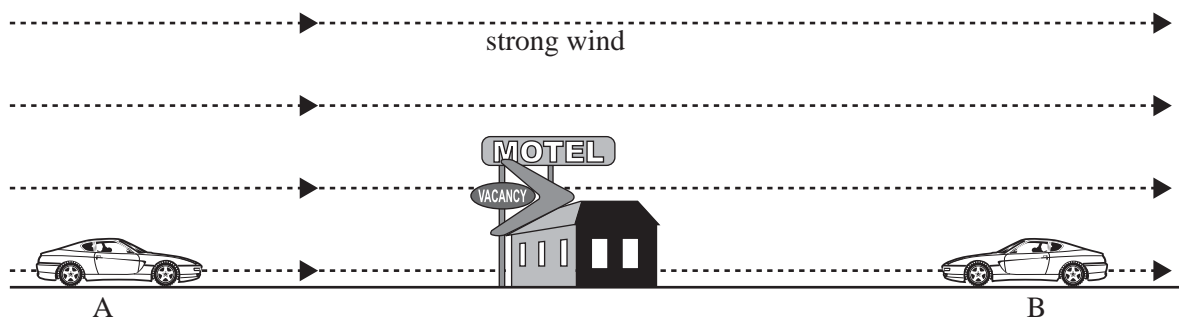

Figure 1

Which of the following options best describes which signal arrives first at the motel?

- A. The sound signal from car A arrives first.
- B. The sound signal from car B arrives first.
- C. Both sound signals arrive at the same time.
- D. The sound signal from car B never reaches the motel.

Question 7

Which of the following statements best describes what the Michelson–Morley experiment attempted to measure?

- A. the speed of Earth through space
- B. changes in the speed of Earth through space
- C. accuracy obtainable with an optical interferometer
- D. differences in the speed of light in different directions

Question 8

One of Einstein’s postulates of special relativity was that ‘the laws of physics are the same in all inertial reference frames’. Scientists are planning an experiment that must be conducted in an inertial reference frame. They choose a location in deep space, far from the gravitational field of any star or planet.

Which of the following is the best option for them to choose?

- A. a laboratory in a stationary slowly rotating spaceship
- B. a laboratory in a spaceship hurtling through space at $0.99c$
- C. a laboratory in a spaceship moving at $0.99c$ that is gradually slowing down
- D. a laboratory in a very slowly moving spaceship that is gaining speed

Question 9

Scientists observe the path of a short-lived elementary particle in a detector. It is created in the detector and exists only for a short time, leaving a path of length 5.4 mm long. The scientists measure its speed as $2.5 \times 10^8 \text{ m s}^{-1}$, giving $\gamma = 1.81$.

What is the proper lifetime of the particle?

- A. $5.3 \times 10^{-11} \text{ s}$
- B. $3.3 \times 10^{-11} \text{ s}$
- C. $1.8 \times 10^{-11} \text{ s}$
- D. $1.2 \times 10^{-11} \text{ s}$

Question 10

Which of the following statements best explains why it is impossible to accelerate particles (such as electrons) so that they are travelling at the speed of light?

- A. It is directly forbidden by one of Einstein’s postulates.
- B. As particles increase in speed, the rest mass (m_0) tends towards an infinite value.
- C. The kinetic energy of particles, given by $E_K = (\gamma - 1)m_0c^2$, tends towards an infinite value.
- D. The speed of particles is given by L/t ; this is equal to $L_0/t_0\gamma^2$ and this value tends towards infinity.

Question 11

Which of the following statements about proper length is the most accurate?

- A. The proper length of an object is always greater than or equal to another measure of the length of the object.
- B. The proper length of an object is always less than another measure of the length of the object.
- C. The proper length of an object is sometimes less than another measure of the length of the object, and sometimes greater than or equal to another measure of the length of the object.
- D. The proper length of an object can only be measured by an observer who is moving relative to the object.

Question 12

A spaceship is travelling through space with a value of $\gamma = 1.04$ relative to a stationary observer.

Which of the following values of γ is closest to that of a spaceship travelling at **twice** the speed, relative to the stationary observer?

- A. 1.08
- B. 1.12
- C. 1.16
- D. 1.20

NO WRITING ALLOWED IN THIS AREA

END OF DETAILED STUDY 1
SECTION B – continued
TURN OVER

Detailed study 2 – Materials and their use in structures

In this section, take the acceleration due to gravity, g , as 10 m s^{-2} .

The following information relates to Questions 1–6.

Engineers are testing samples of different types of steel to determine the best type to use in construction of a bridge.

The samples they are testing have a cross-section area of $2.0 \times 10^{-5} \text{ m}^2$. They are all 0.10 m long.

The samples are under tension.

They first test a sample of material P. The force-extension graph for this test is shown in Figure 1.

The sample breaks at X.

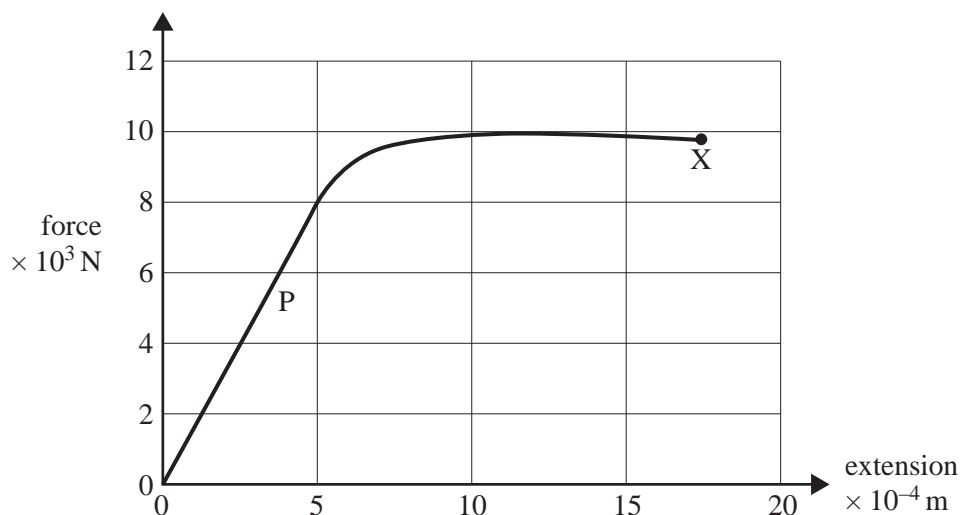

Figure 1

In Questions 1–4, a tension force of $8.0 \times 10^3 \text{ N}$ is applied to the sample.

Question 1

Which of the following best gives the stress (σ)?

- A. $8.0 \times 10^3 \text{ N m}^{-2}$
- B. $4.0 \times 10^7 \text{ N m}^{-2}$
- C. $4.0 \times 10^8 \text{ N m}^{-2}$
- D. $4.0 \times 10^9 \text{ N m}^{-2}$

Question 2

Which of the following best gives the strain (ϵ) when the force is $8.0 \times 10^3 \text{ N}$?

- A. 5.0×10^{-7}
- B. 5.0×10^{-4}
- C. 5.0×10^{-3}
- D. 5.0

Question 3

Which of the following best gives Young's modulus for material P?

- A. $3.0 \times 10^7 \text{ N m}^{-2}$
- B. $8.0 \times 10^{10} \text{ N m}^{-2}$
- C. $1.3 \times 10^{11} \text{ N m}^{-2}$
- D. $8.0 \times 10^{11} \text{ N m}^{-2}$

Question 4

Which of the following best gives the energy stored in the sample when the force of $8.0 \times 10^3 \text{ N}$ is acting on it?

- A. $2.0 \times 10^{-7} \text{ J}$
- B. 2.0 J
- C. 4.0 J
- D. $8.0 \times 10^6 \text{ J}$

Question 5

Which of the following is closest to the measure of the toughness of material P?

- A. $2.7 \times 10^{-5} \text{ J m}^{-3}$
- B. 10 J m^{-3}
- C. 16.5 J m^{-3}
- D. $6.6 \times 10^6 \text{ J m}^{-3}$

SECTION B – Detailed study 2 – continued
TURN OVER

NO WRITING ALLOWED IN THIS AREA

Question 6

The engineers test another sample of a different material, material Q.

The force-extension graph for the sample of material Q is given in Figure 2.

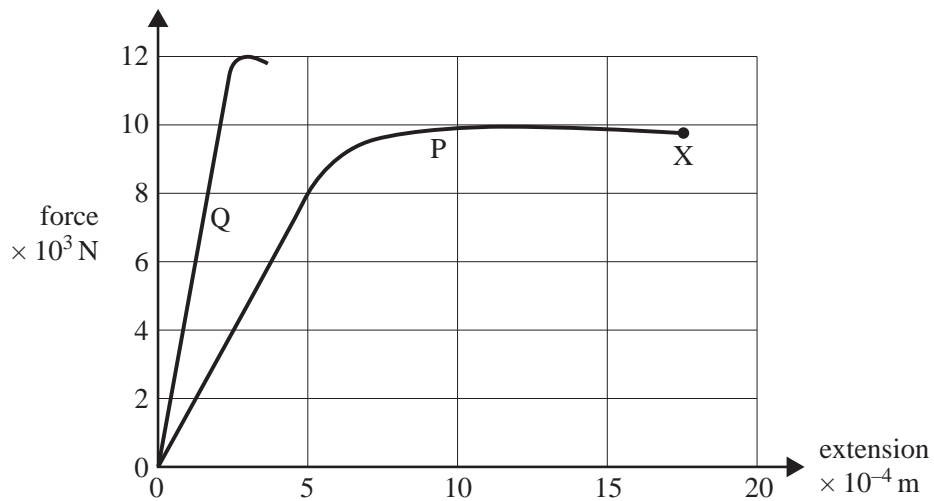

Figure 2

The engineers decide against using material Q, preferring P.

Using only the data above, which of the following is the most likely reason for this decision?

- A. P is stronger than Q.
- B. Q is more brittle than P.
- C. Compared with P, Q would stretch too much at a given load.
- D. Young's modulus is greater for P than Q, indicating more strength.

NO WRITING ALLOWED IN THIS AREA

The following information relates to Questions 7 and 8.

A school crossing sign is supported by a rigid rod, AC, smoothly hinged to an upright pole at point A, and a cable, BC, as shown in Figure 3.

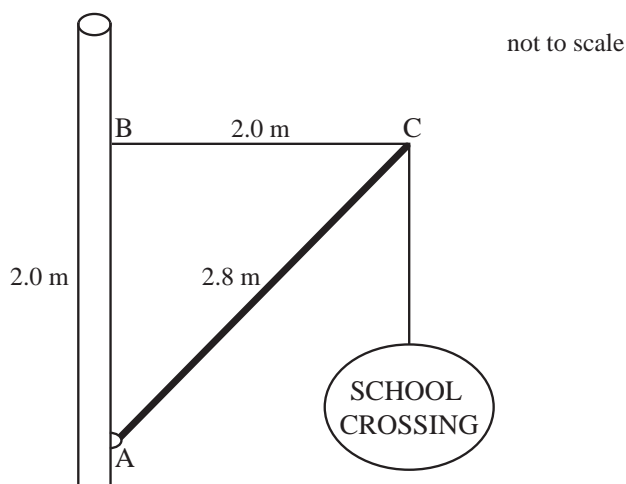

Figure 3

Length of rod AC = 2.8 m

Length of cable BC = 2.0 m

Length AB = 2.0 m

Mass of sign = 40 kg

Ignore mass of rod and all cables.

Question 7

Which of the following best describes the stress in AC and BC?

- A. AC and BC are both in tension.
- B. AC and BC are both in compression.
- C. AC is in tension, BC in compression.
- D. AC is in compression, BC in tension.

Question 8

Which of the following best gives the magnitude of the force in the cable BC?

- A. 40 N
- B. 60 N
- C. 400 N
- D. 560 N

SECTION B – Detailed study 2 – continued
TURN OVER

The following information relates to Questions 9 and 10.

A diving board is constructed of concrete (strong in compression), reinforced by steel wires (strong in tension). It is mounted with two supports at A and B, as shown. The board has a mass of 80 kg and a length of 4.0 m. A diver of mass 100 kg is standing stationary on the very end of the board at C. Support A is at one end of the board. Support B is 1.0 m from A. The situation is shown in Figure 4.

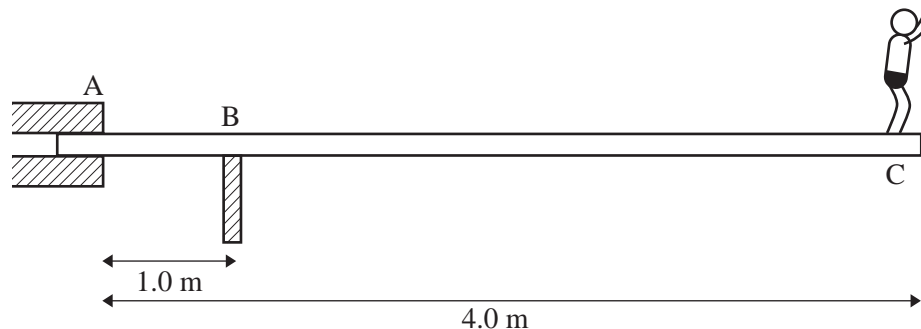

Figure 4

Question 9

Which of the following best gives the magnitude of the force by the support at B on the board?

- A. 560 N
- B. 1800 N
- C. 5600 N
- D. 18000 N

Question 10

Which of the following diagrams best gives the optimum placement for the steel wires in the diving board?

- A.
- B.
- C.
- D.

----- steel wires

NO WRITING ALLOWED IN THIS AREA

The following information relates to Questions 11 and 12.

A cable supporting a large mass is wound around a drum as shown in Figure 5. The drum consists of a solid metal cylinder. The drum is held stationary.

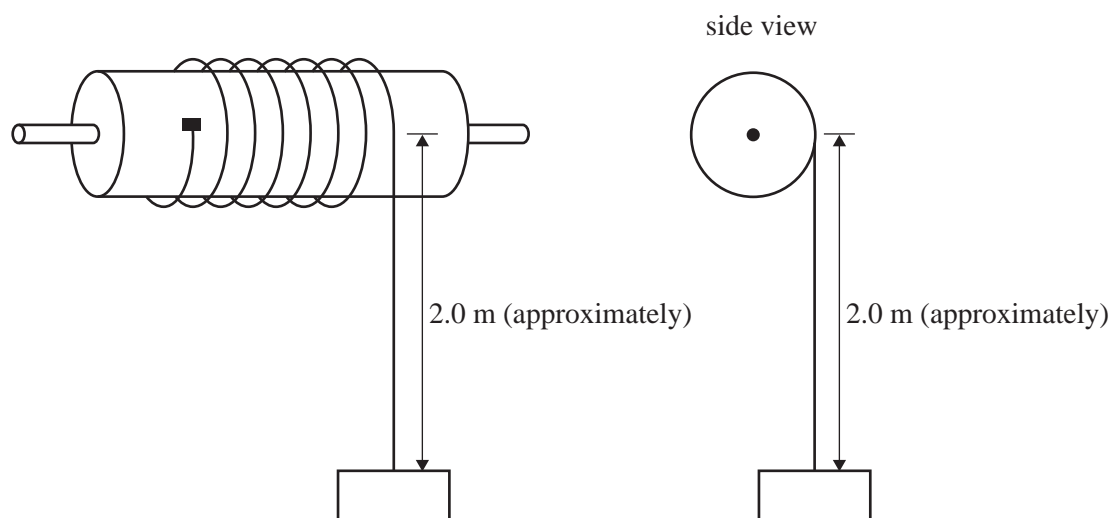

Figure 5

Question 11

Which of the following best describes the type of stress force on the drum?

- A. shear
- B. elastic
- C. tension
- D. plastic

Question 12

The cable has an unstretched length of 2.0 m. When the mass is attached, the strain (ϵ) in the cable is 0.010.

Assuming no slippage of the cable or movement of the cylinder, which of the following best indicates by how much the cable stretches?

- A. 0.020 cm
- B. 2.0 cm
- C. 10 cm
- D. 20 cm

END OF DETAILED STUDY 2
SECTION B – continued
TURN OVER

Detailed study 3 – Further electronics

The following information relates to Questions 1–4.

John is designing, building and testing an AC to DC power supply system to provide the high voltage to a cathode-ray tube. The DC voltage has to be approximately 5000 V and the effective resistance of the cathode-ray tube in the circuit is $5\text{ M}\Omega$ ($5 \times 10^6\ \Omega$).

The circuit is shown below in Figure 1.

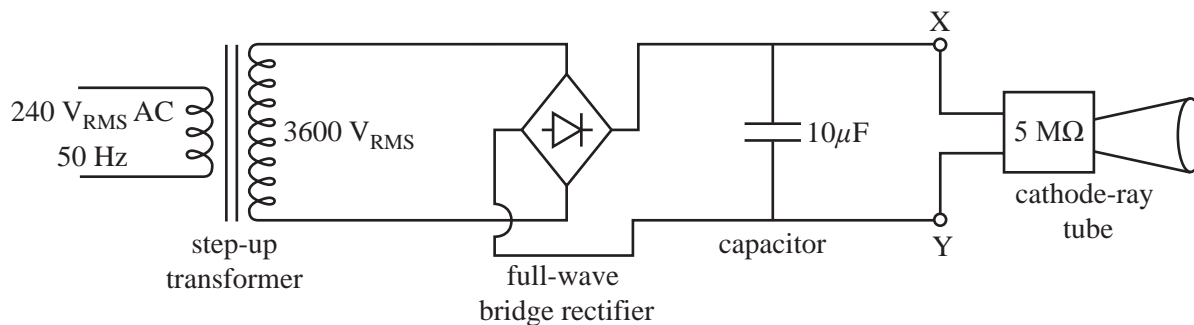

Figure 1

The bridge rectifier consists of four diodes connected appropriately, and the smoothing capacitor has a value of $10\ \mu\text{F}$ ($10 \times 10^{-6}\text{ F}$).

Question 1

Which of the following best gives the time constant, τ , for the circuit consisting of the smoothing capacitor and cathode-ray tube?

- A. $5 \times 10^{-6}\text{ s}$
- B. 0.5 s
- C. 5 s
- D. 50 s

NO WRITING ALLOWED IN THIS AREA

Question 2

Which of the following graphs best shows the signal as observed across XY?

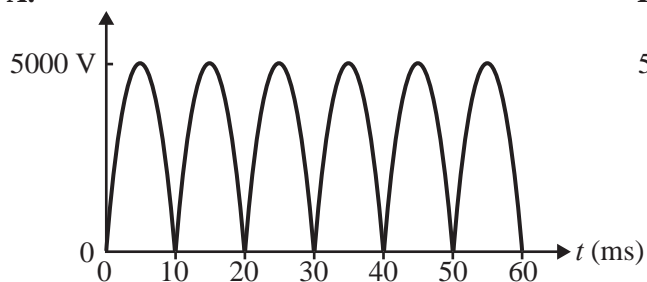
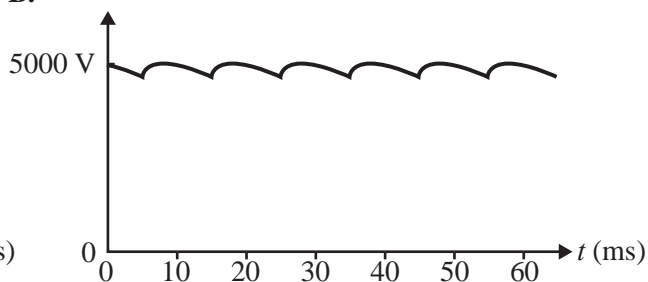
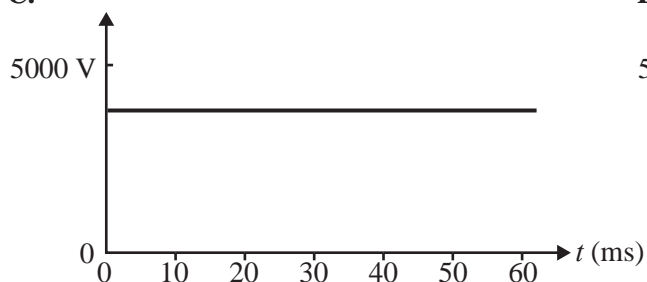
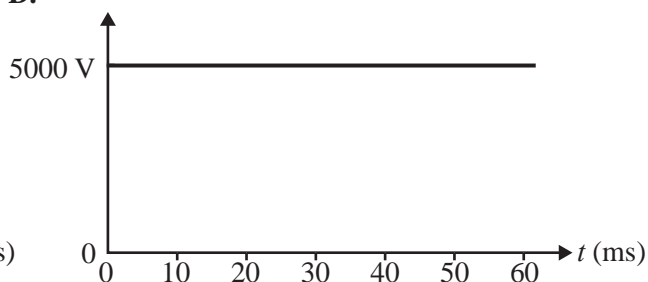
A.**B.****C.****D.****Question 3**

The next step of the design of the system is to select the power of the transformer. This factor affects the price and the size of the transformer, so John must choose the smallest transformer that delivers the required power.

A catalogue quoted only the following four available power ratings for transformers: 2 W, 10 W, 100 W, 1000 W.

Which of the following will be the **minimum** power rating transformer to meet the task?

- A. 2 W
- B. 10 W
- C. 100 W
- D. 1000 W

Question 4

Bill lives in the USA. He intends to build the same system as John. Due to the fact that the mains voltage in the USA is $110 V_{\text{RMS}}$ and 60 Hz instead of $240 V_{\text{RMS}}$ and 50 Hz in Australia, Bill has to make some changes to the design.

He has to replace the transformer.

It is an ideal transformer.

Which of the following best gives the reason for this?

- A. A different transformer is needed to allow for the different input voltage only.
- B. A different transformer is needed to allow for the different frequency only.
- C. A different transformer is needed to allow for both the different input voltage and different frequency.
- D. A different transformer is needed to allow for the different power required.

Question 5

Mary wants to build a regulated power supply powered by a 9 V battery. The required output voltage of the power supply has to be 5.5 V to suit the music player she bought overseas.

She built the regulator with the electric circuit depicted below, consisting of a 9 V battery, a 20 k Ω resistor and a 5.5 V Zener diode.

The circuit is shown in Figure 2a.

The voltage-current characteristics of the Zener diode are depicted in Figure 2b.

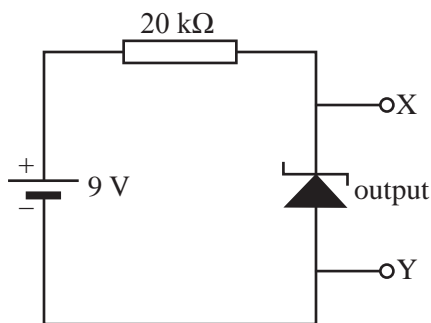

Figure 2a

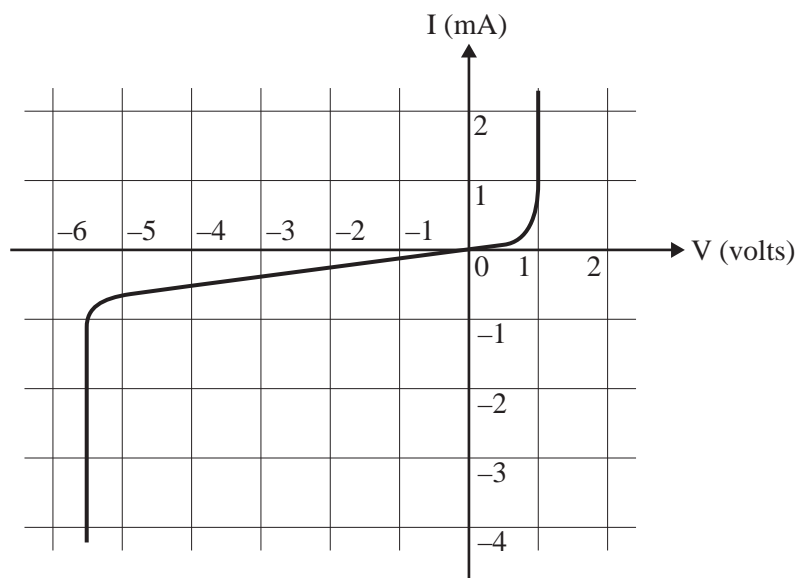

Figure 2b

She measured the output voltage V_{XY} to be 3.5 V.

Which of the following is the most likely reason for the output being lower than she wanted?

- A. The Zener diode requires at least 1 mA to operate correctly, and the current will be less than this.
- B. The 20 k Ω resistor is to protect the Zener diode from excessive currents, and the value of the resistor is too low.
- C. The battery has too high a voltage to allow 5.5 V across XY.
- D. The Zener diode is installed incorrectly, with its polarity reversed.

NO WRITING ALLOWED IN THIS AREA

CONTINUES OVER PAGE

SECTION B – Detailed study 3 – continued
TURN OVER

The following information relates to Questions 6–8.

Mary decides to use a transformer-rectifier power supply in place of the battery to provide the 5.5 V she needs. It is connected to a $240 \text{ V}_{\text{RMS}}$ AC 50 Hz supply. The output of the secondary windings of the transformer is $10 \text{ V}_{\text{RMS}}$. The circuit for this is shown below in Figure 3a.

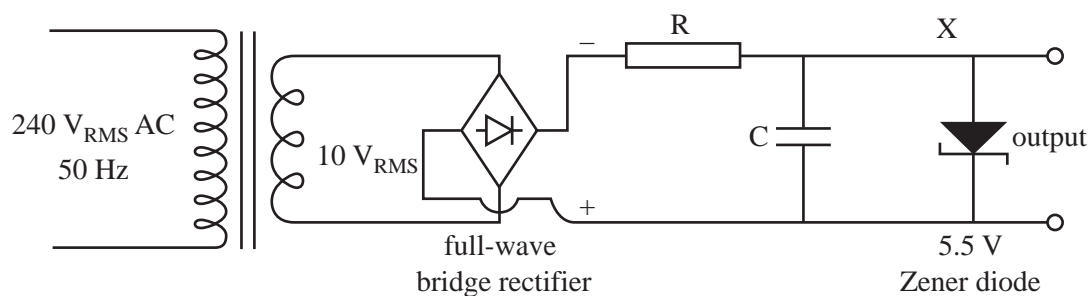

Figure 3a

Question 6

The primary windings of the transformer have 4800 turns.

Which of the following best gives the number of windings required in the secondary windings?

- A. 10
- B. 200
- C. 4800
- D. 1 152 000

Question 7

Initially the circuit operates correctly, providing 5.5 V DC smoothed output.

However, a fault then develops and the output is as shown in Figure 3b below.

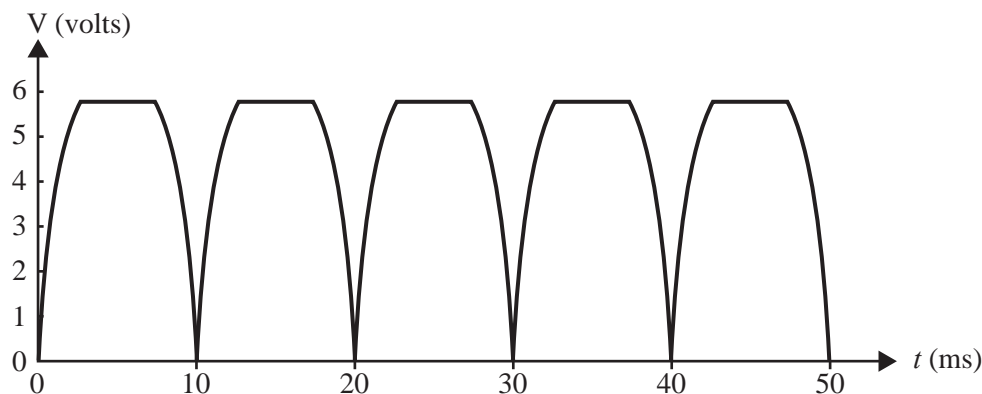

Figure 3b

Which of the following is the most likely cause of this fault?

A failure of

- A. the transformer.
- B. the capacitor used for smoothing the signal.
- C. all the diodes in the bridge rectifier (blown).
- D. one only of the diodes in the bridge rectifier (blown).

Question 8

After fixing this fault another develops, causing the signal below at the output.

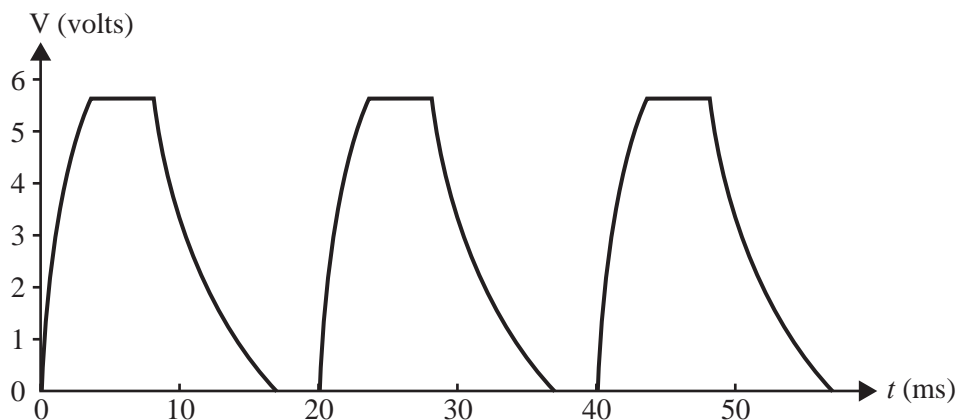

Figure 3c

Which of the following is the most likely cause of this fault?

A failure of

- A. one only of the diodes in the bridge rectifier (blown).
- B. all the diodes in the bridge rectifier (blown).
- C. the capacitor used for smoothing the signal.
- D. the transformer.

SECTION B – Detailed study 3 – continued
TURN OVER

The following information relates to Questions 9 and 10.

Tom suggests that a much cheaper circuit could be used to provide the 5.5 V DC smoothed output required. This circuit is shown in Figure 4.

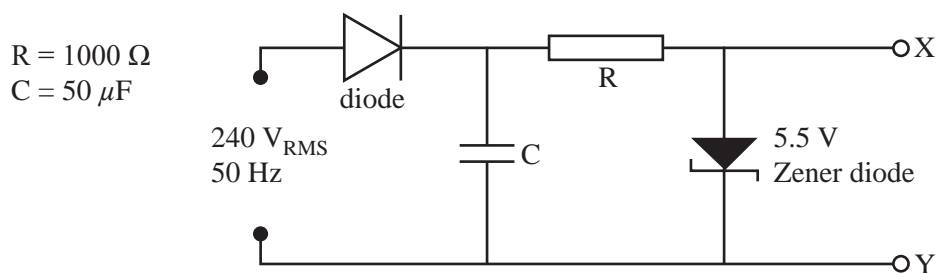
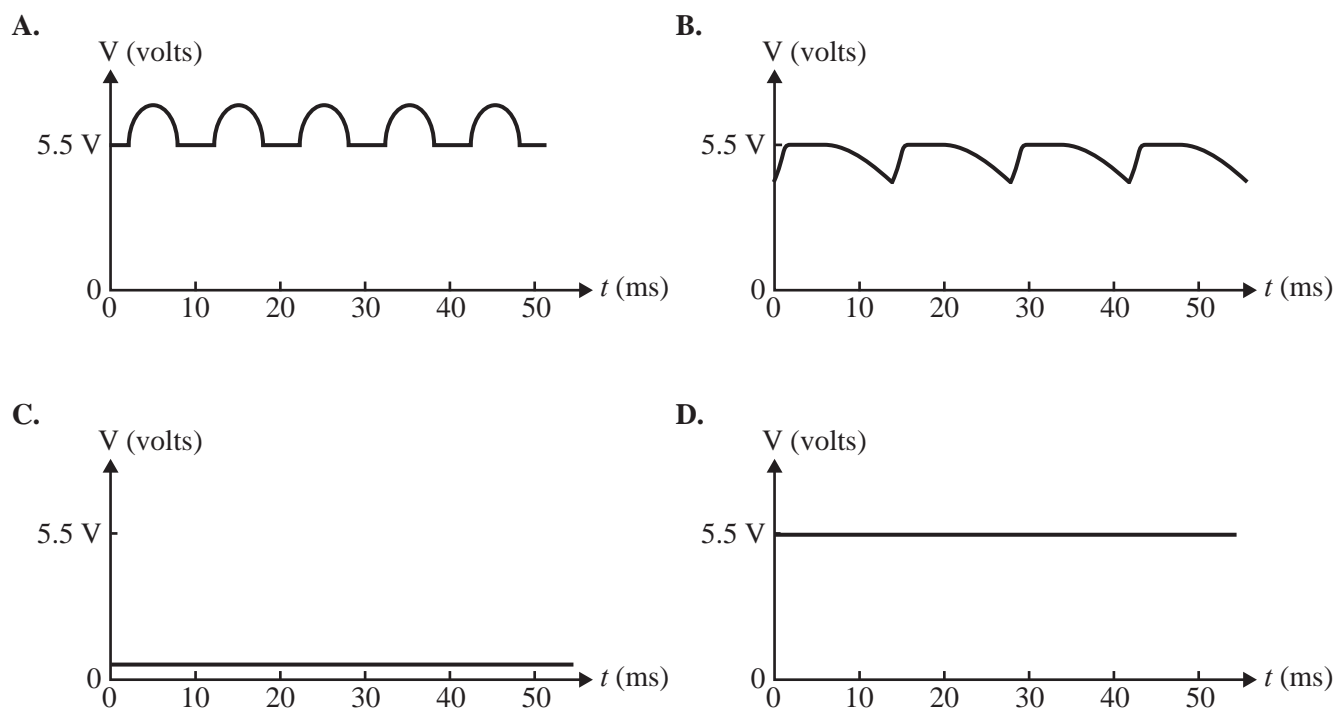

Figure 4

Question 9

Which of the following will best show the shape of the output as seen by an oscilloscope connected across XY?



Question 10

While this cheaper circuit is sometimes used, it is normally avoided because of safety concerns. If a particular component fails, 240 V will appear across the output.

The failure of which of the following components would cause 240 V to appear across the output? Assume that the failure of the component will cause an open circuit (that is, a break in the circuit where the component was).

- A. Zener diode
- B. resistor
- C. capacitor
- D. diode

The following information relates to Questions 11 and 12.

Mickie is attempting to measure the input resistance of a piece of electronic equipment, E. She sets up the following circuit.

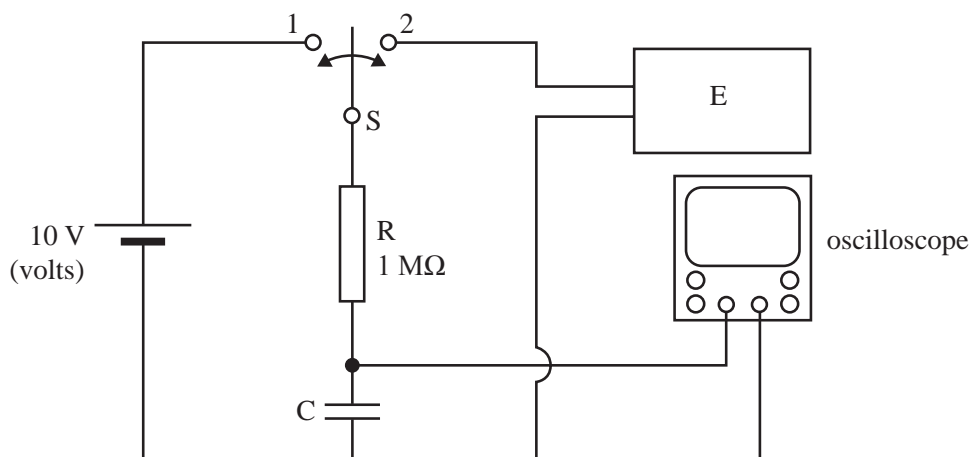

Figure 5

Question 11

She uses the oscilloscope to observe the voltage across capacitor C. Assume the oscilloscope has a very large input resistance.

The capacitor is initially uncharged.

Moving the switch to position 1, she observes the following signal on the oscilloscope.

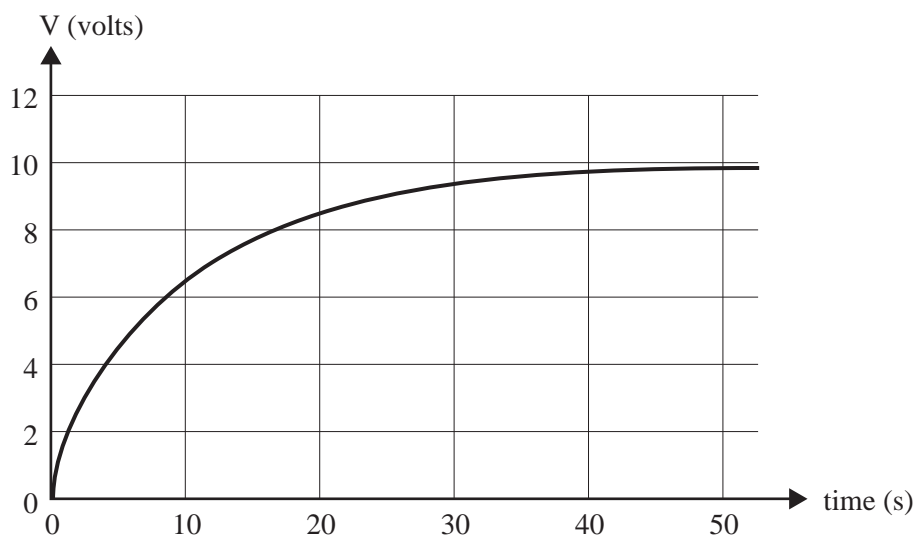

Figure 6

Which of the following best gives the value of the capacitor C?

- A. $5 \mu\text{F}$
- B. $10 \mu\text{F}$
- C. $50 \mu\text{F}$
- D. $1000 \mu\text{F}$

Question 12

After 5 minutes, she moves the switch to position 2 and observes the following signal.

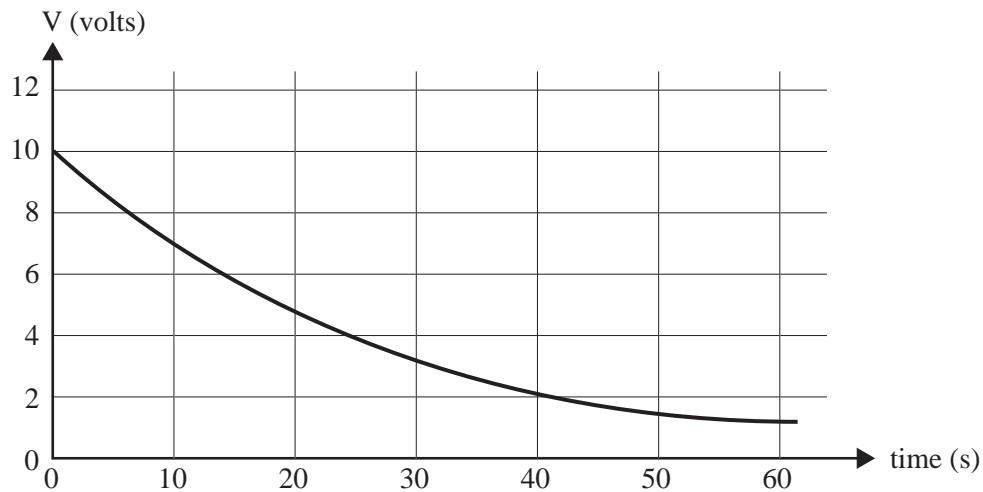

Figure 7

Which of the following best gives the value of the input resistance of the piece of equipment, E?

- A. $0.5 \text{ M}\Omega$
- B. $1.0 \text{ M}\Omega$
- C. $1.6 \text{ M}\Omega$
- D. $2.6 \text{ M}\Omega$

NO WRITING ALLOWED IN THIS AREA

END OF QUESTION AND ANSWER BOOK



**Victorian Certificate of Education
2011**

PHYSICS

Written examination 1

Tuesday 14 June 2011

Reading time: 11.45 am to 12.00 noon (15 minutes)

Writing time: 12.00 noon to 1.30 pm (1 hour 30 minutes)

FORMULA SHEET

Directions to students

- A question and answer book is provided with this formula sheet.

Students are NOT permitted to bring mobile phones and/or any other unauthorised electronic devices into the examination room.

1	velocity; acceleration	$v = \frac{\Delta x}{\Delta t}; \quad a = \frac{\Delta v}{\Delta t}$
2	equations for constant acceleration	$v = u + at$ $x = ut + \frac{1}{2}at^2$ $v^2 = u^2 + 2ax$ $x = \frac{1}{2}(v + u)t$
3	Newton's second law	$\Sigma F = ma$
4	circular motion	$a = \frac{v^2}{r} = \frac{4\pi^2 r}{T^2}$
5	Hooke's law	$F = -kx$
6	elastic potential energy	$\frac{1}{2}kx^2$
7	gravitational potential energy near the surface of the Earth	mgh
8	kinetic energy	$\frac{1}{2}mv^2$
9	Newton's law of universal gravitation	$F = G \frac{M_1 M_2}{r^2}$
10	gravitational field	$g = G \frac{M}{r^2}$
11	stress	$\sigma = \frac{F}{A}$
12	strain	$\varepsilon = \frac{\Delta L}{L}$
13	Young's modulus	$E = \frac{\text{stress}}{\text{strain}}$
14	transformer action	$\frac{V_1}{V_2} = \frac{N_1}{N_2}$
15	AC voltage and current	$V_{\text{RMS}} = \frac{1}{2\sqrt{2}} V_{\text{p-p}} \quad I_{\text{RMS}} = \frac{1}{2\sqrt{2}} I_{\text{p-p}}$
16	voltage; power	$V = RI \quad P = VI = I^2 R$

17	resistors in series	$R_T = R_1 + R_2$
18	resistors in parallel	$\frac{1}{R_T} = \frac{1}{R_1} + \frac{1}{R_2}$
19	capacitors	time constant : $\tau = RC$
20	Lorentz factor	$\gamma = \frac{1}{\sqrt{1 - v^2 / c^2}}$
21	time dilation	$t = t_o \gamma$
22	length contraction	$L = L_o / \gamma$
23	relativistic mass	$m = m_o \gamma$
24	total energy	$E_{total} = E_k + E_{rest} = mc^2$
25	universal gravitational constant	$G = 6.67 \times 10^{-11} \text{ N m}^2 \text{ kg}^{-2}$
26	mass of Earth	$M_E = 5.98 \times 10^{24} \text{ kg}$
27	radius of Earth	$R_E = 6.37 \times 10^6 \text{ m}$
28	mass of the electron	$m_e = 9.1 \times 10^{-31} \text{ kg}$
29	charge on the electron	$e = -1.6 \times 10^{-19} \text{ C}$
30	speed of light	$c = 3.0 \times 10^8 \text{ m s}^{-1}$

Prefixes/Units

p = pico = 10^{-12}

n = nano = 10^{-9}

μ = micro = 10^{-6}

m = milli = 10^{-3}

k = kilo = 10^3

M = mega = 10^6

G = giga = 10^9

t = tonne = 10^3 kg

END OF FORMULA SHEET