



# Victorian Certificate of Education

## 2008

SUPERVISOR TO ATTACH PROCESSING LABEL HERE

STUDENT NUMBER

Letter

Figures

Words

# PHYSICS

## Written examination 1

Wednesday 11 June 2008

Reading time: 11.45 am to 12.00 noon (15 minutes)

Writing time: 12.00 noon to 1.30 pm (1 hour 30 minutes)

## QUESTION AND ANSWER BOOK

### Structure of book

#### Section A – Areas of study

<i>Number of Areas of study</i>	<i>Number of Areas of study to be answered</i>	<i>Number of marks</i>
2	2	64

#### Section B – Detailed studies

<i>Number of Detailed studies</i>	<i>Number of Detailed studies to be answered</i>	<i>Number of marks</i>
3	1	26
		Total 90

- Students are permitted to bring into the examination room: pens, pencils, highlighters, erasers, sharpeners, rulers, up to two pages (one A4 sheet) of pre-written notes (typed or handwritten) and one scientific calculator.
- Students are NOT permitted to bring into the examination room: blank sheets of paper and/or white out liquid/tape.

#### Materials supplied

- Question and answer book of 47 pages. The question and answer book has a detachable data sheet in the centrefold.
- Answer sheet for multiple-choice questions.

#### Instructions

- Detach the data sheet from the centre of this book during reading time.
- Write your **student number** in the space provided above on this page.
- Check that your **name** and **student number** as printed on your answer sheet for multiple-choice questions are correct, **and** sign your name in the space provided to verify this.
- Unless otherwise indicated, the diagrams in this book are **not** drawn to scale.
- All written responses must be in English.

#### At the end of the examination

- Place the answer sheet for multiple-choice questions inside the front cover of this book.

**Students are NOT permitted to bring mobile phones and/or any other unauthorised electronic devices into the examination room.**

[www.theallpapers.com](http://www.theallpapers.com)

**SECTION A****Instructions for Section A**

Answer **all** questions **for both** Areas of study in this section in the spaces provided.

Where an answer box has a unit printed in it, give your answer in that unit.

You should take the value of  $g$  to be  $10 \text{ m s}^{-2}$ .

<b>Areas of study</b>	<b>Page</b>
Motion in one and two dimensions .....	4
Electronics and photonics .....	18

**This page is blank**

## Area of study 1 – Motion in one and two dimensions

Use the following information to answer Questions 1 and 2.

A tugboat is towing a ship with a tow rope as shown in Figure 1.

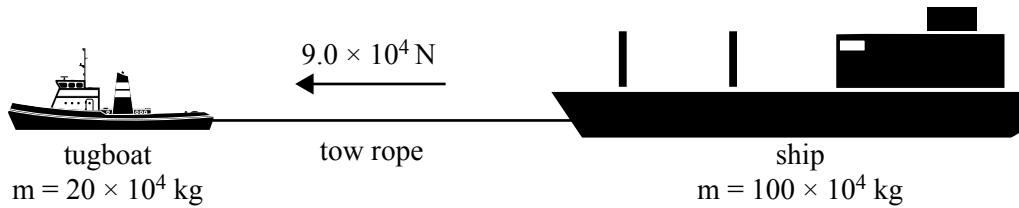

Figure 1

Mass of tugboat =  $20 \times 10^4 \text{ kg}$

Mass of ship =  $100 \times 10^4 \text{ kg}$

The tugboat exerts a constant force of  $9.0 \times 10^4 \text{ N}$  on the tow rope.

The water resistance on the ship as a function of speed is shown in Figure 2.

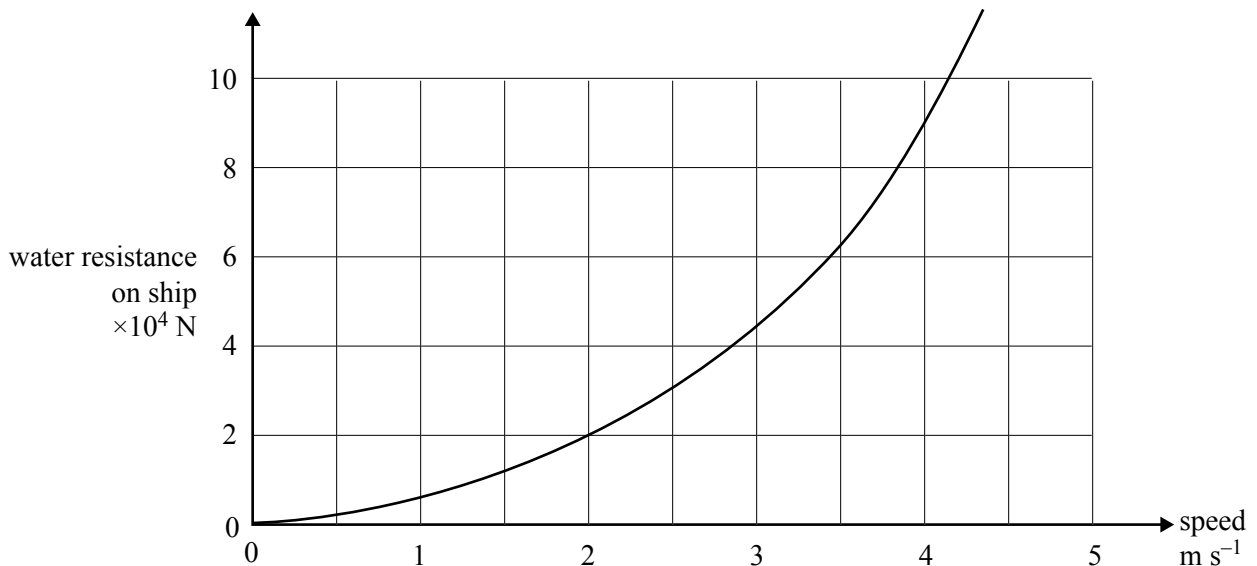

Figure 2

**Question 1**

What is the acceleration of the ship when the tugboat and ship are travelling at  $2.0 \text{ m s}^{-1}$ ?

You must show your working.

$\text{m s}^{-2}$

2 marks

**Question 2**

After a time, the tugboat and ship are travelling at a constant speed.

What is this constant speed?

$\text{m s}^{-1}$

2 marks

Use the following information to answer Questions 3 and 4.

Students set up an experiment to investigate circular motion. They use a battery-powered model car. The car is connected with a string to a fixed point as shown in Figure 3a. A diagram of the experimental arrangement they use is shown in Figure 3b where Y represents the fixed point and X represents the car. The car has a mass of 2.4 kg. It moves at a constant speed of  $2.0 \text{ m s}^{-1}$ , around a circle of radius 1.6 m.

Ignore mass of string and measuring device.

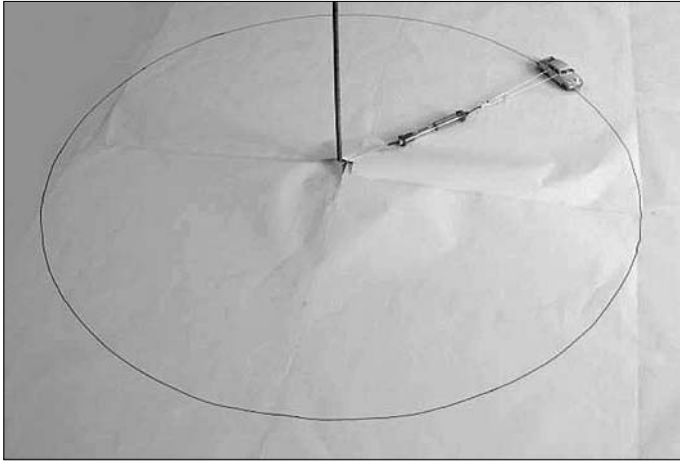

Figure 3a

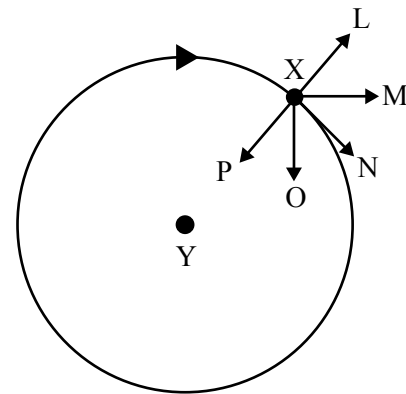

Figure 3b

**Question 3**

What is the tension in the string?

You must show your working.

N

2 marks

**Question 4**

Which of the arrows (L–P) in Figure 3b best indicates the direction of the resultant force on the car when it is at the point X?

2 marks

**This page is blank**

Use the following information to answer Questions 5–7.

A batsman hits a cricket ball (from ground level) at a speed of  $30.0 \text{ m s}^{-1}$  and at an angle of  $36.9^\circ$  to the horizontal as shown in Figure 4. Air resistance can be ignored.

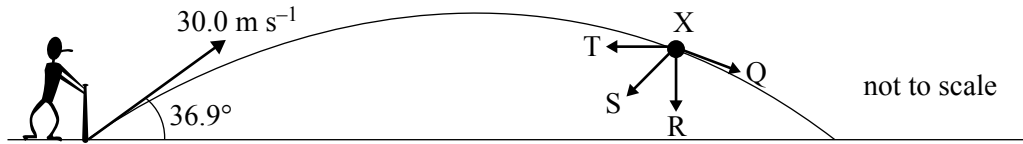

Figure 4

**Question 5**

What is the maximum height that the ball reaches?

You must show your working.

2 marks

**Question 6**

Which of the arrows (Q–T) in Figure 4 best represents the resultant force on the ball at point X?

2 marks



An advertising board is now placed on the boundary of the cricket ground at a distance 72.0 m from the batsman as shown in Figure 5.

**Question 7**

Assuming the ball is hit exactly the same way as in the previous question, at what height above the ground will the ball strike the advertising board?

You must show your working.

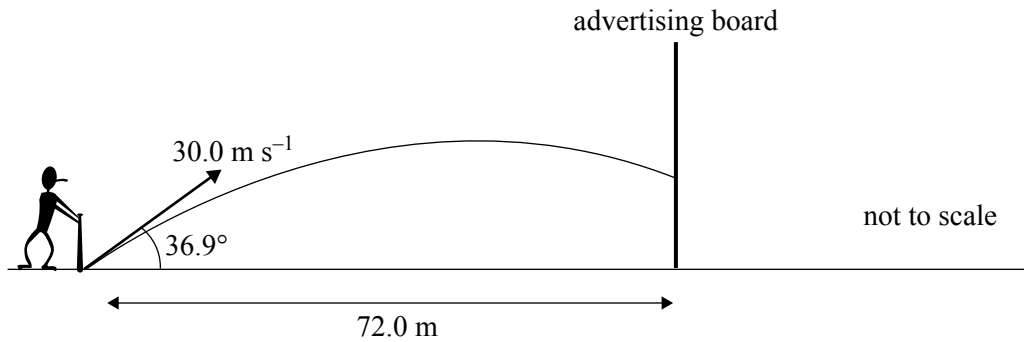

**Figure 5**

m
---

3 marks

Use the following information to answer Questions 8–11.

A locomotive, of mass  $20 \times 10^3$  kg, moving at  $8.0 \text{ m s}^{-1}$  east, collides with and couples to three trucks, each of mass  $20 \times 10^3$  kg, initially stationary, as shown in Figure 6.

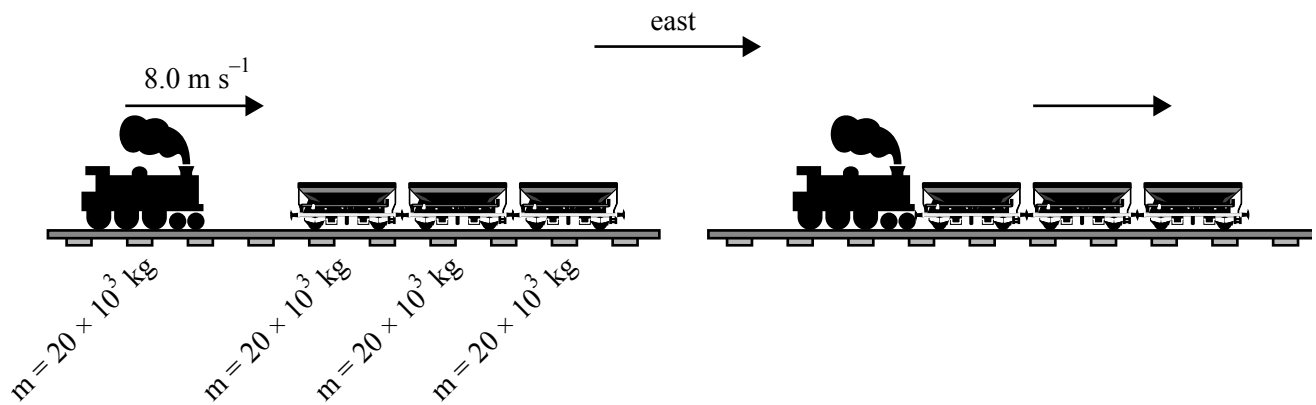

Figure 6

### Question 8

What is the speed of the coupled locomotive and trucks after the collision?

You must show your working.

$\text{m s}^{-1}$
-------------------

2 marks

### Question 9

What is the impulse given **to** the locomotive **by** the trucks in the collision (magnitude and direction)?

You must show your working.

$\text{kg m s}^{-1}$	direction
----------------------	-----------

3 marks

**Question 10**

Was this collision elastic or inelastic?

Support your conclusion by appropriate calculation.

elastic/inelastic?

3 marks

During the collision, the magnitude of the average force exerted by the locomotive on the trucks is  $F_L$  and the magnitude of the average force exerted by the trucks on the locomotive is  $F_T$ .

**Question 11**

Will  $F_L$  be greater, equal to, or less than  $F_T$ ?

Explain your answer.

---

---

---

---

---

---

---

---

2 marks

Use the following information to answer Questions 12–14.

A novelty toy consists of a metal ball of mass  $0.20 \text{ kg}$  hanging from a spring of spring constant  $k = 10 \text{ N m}^{-1}$ . The spring is attached to the ceiling of a room as shown in Figure 7. Ignore the mass of the spring.

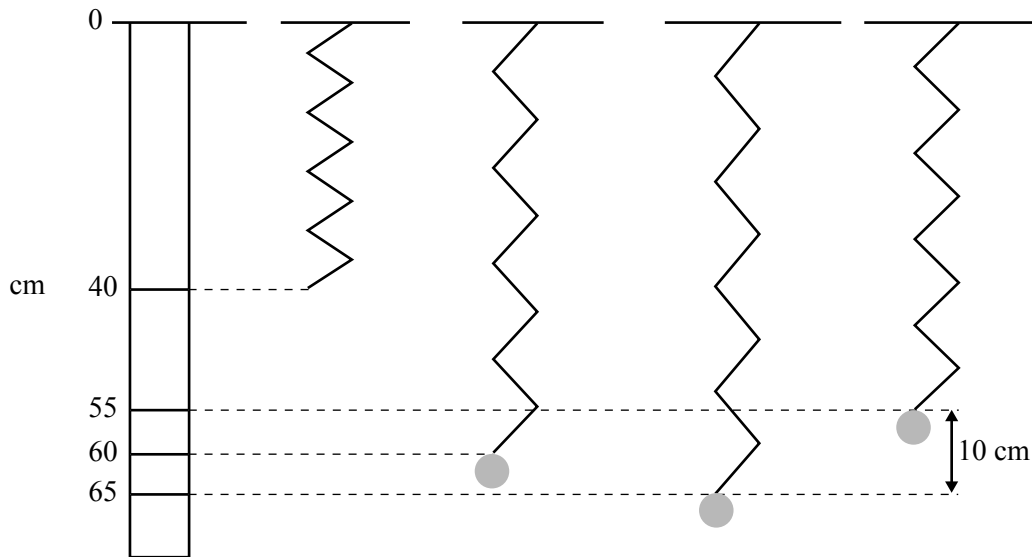

**Figure 7**

Without the ball attached, the spring has an unstretched length of  $40 \text{ cm}$ . When the ball is attached, but not oscillating, the spring stretches to  $60 \text{ cm}$ .

**Question 12**

How much energy is stored in the spring when the ball is hanging stationary on it?

You must show your working.

J
---

2 marks

The ball is now pulled down a further 5 cm and released so that it oscillates vertically over a range of approximately 10 cm.

Gravitational potential energy is measured from the level at which the ball is released. Ignore air resistance.

Use Graphs A–E in answering Questions 13 and 14.

A.

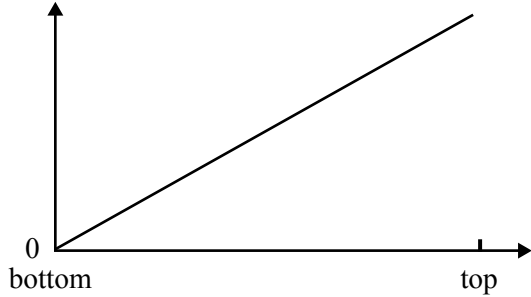

B.

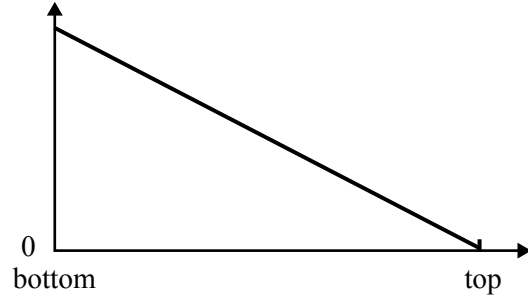

C.



D.

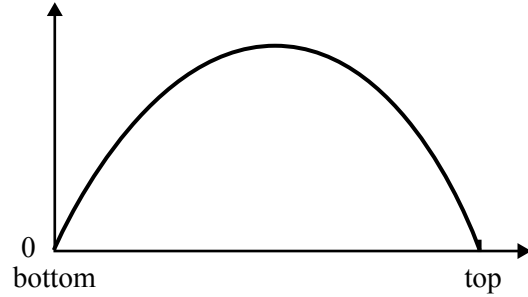

E.

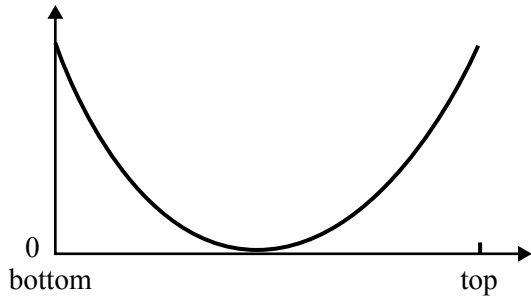

### Question 13

Which of the graphs best represents the shape of the graph of **kinetic** energy of the system as a function of height?

2 marks

### Question 14

Which of the graphs best represents the **gravitational potential** energy of the system as a function of height?

2 marks

Figure 8 shows the orbit of a comet around the Sun.

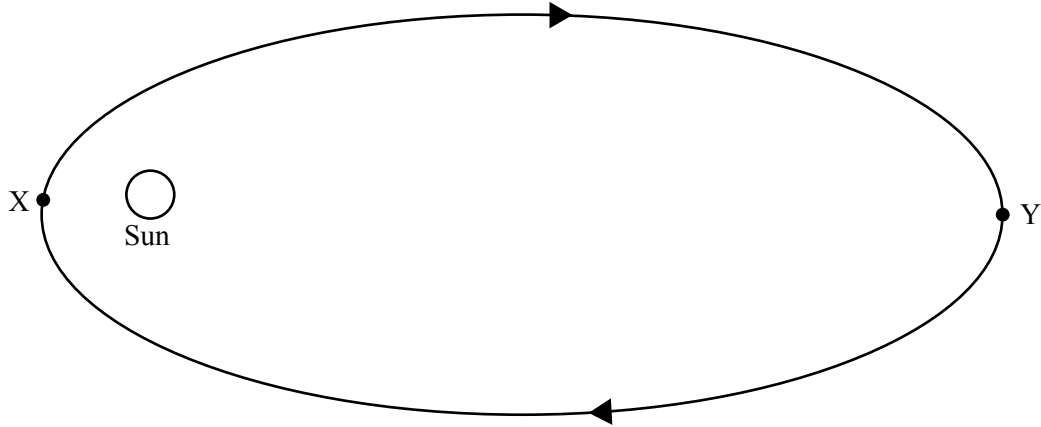

Figure 8

**Question 15**

Describe how the **speed** and **total energy** of the comet vary as it moves around its orbit from X to Y.

---

---

---

---

---

---

---

2 marks

**This page is blank**

Use the following information to answer Questions 16 and 17.

In March 1999 the Mars Global Surveyor (Figure 9) entered its final circular orbit about Mars, sending information about Mars back to Earth.

Below is some data that you may find useful when answering Questions 16 and 17.

$$G = 6.67 \times 10^{-11} \text{ N m}^2 \text{ kg}^{-2}$$

Mass of Mars Global Surveyor = 930 kg

Mass of Mars =  $6.42 \times 10^{23}$  kg

Radius of orbit of Mars Global Surveyor =  $3.83 \times 10^6$  m



**Figure 9**

**Question 16**

Calculate the gravitational force on the Mars Global Surveyor.

You must show your working.

N
---

2 marks



**Question 17**

Calculate the period of orbit of the Mars Global Surveyor.  
You must show your working.

	s
--	---

3 marks

**Area of study 2 – Electronics and photonics**

The diagram below (Figure 1) shows the current-voltage characteristics for a Light Emitting Diode (LED).

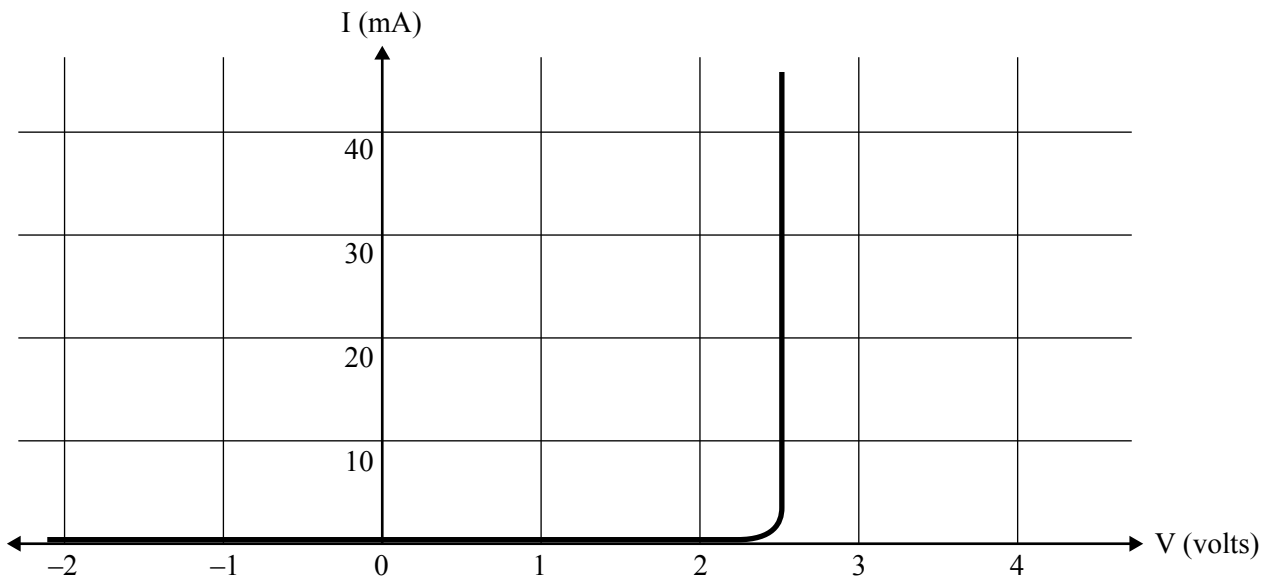

**Figure 1**

The LED is placed in the circuit shown in Figure 2 below.

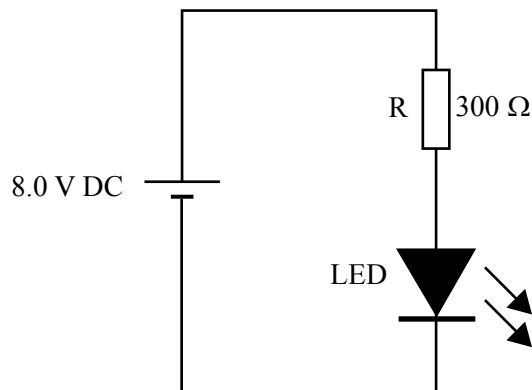

**Figure 2**

**Question 1**

What will be the current through the LED? Show your working.

mA

2 marks

Use the following information to answer Questions 2–7.

Figure 3 below shows the circuit for an npn transistor acting as a single-stage transistor amplifier.

Use this circuit in answering Questions 2–7.

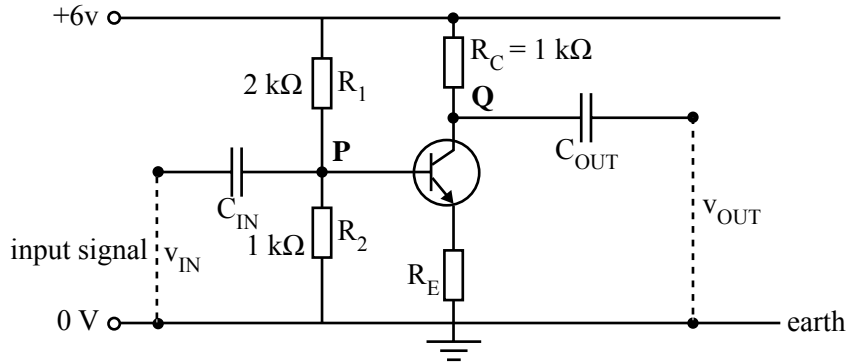

Figure 3

### Question 2

With no input signal, the DC voltage is measured between point P and earth.

What will be the value of this DC voltage?

You must show your working.

V
---

2 marks

Still with no input signal, the current through  $R_C$  is measured to be 3 mA.

### Question 3

What will be the voltage measured between point Q and earth?

You must show your working.

V
---

2 marks

### Question 4

What is the power dissipated in resistor  $R_C$ ?

You must show your working.

W
---

2 marks

The graph of  $v_{OUT}$  versus  $v_{IN}$  for the transistor amplifier is shown in Figure 4.

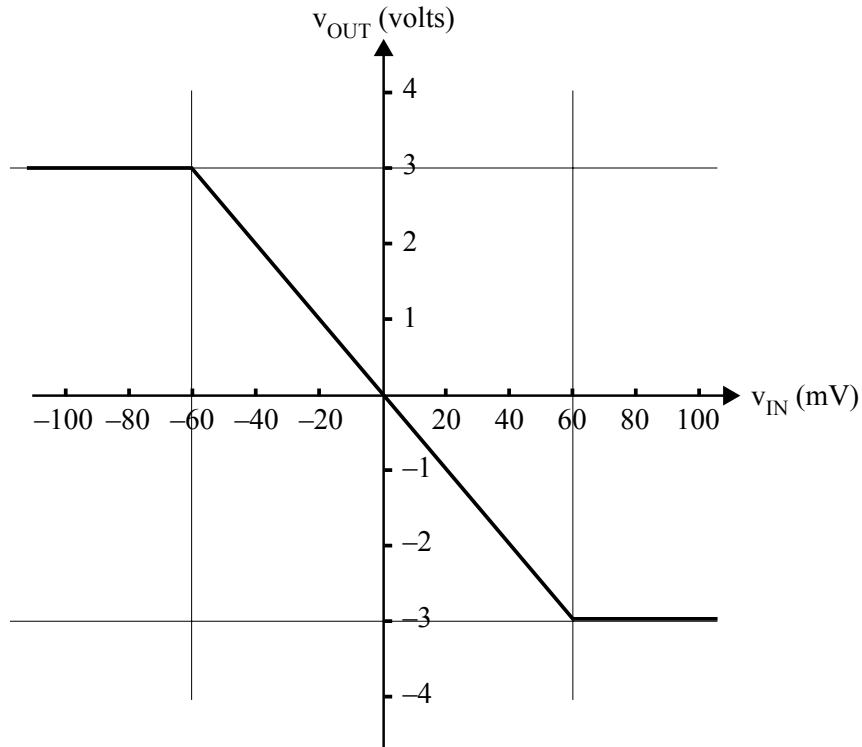

**Figure 4**

**Question 5**

What is the voltage amplification of the transistor amplifier?

You must show your working.

2 marks

**Question 6**

Explain the shape of the graph in Figure 4 in terms of the operation of the transistor.

Your explanation should include why the graph shown has a negative slope, and why it has horizontal sections at  $v_{IN} > +60$  mV and  $v_{IN} < -60$  mV.

---



---



---



---



---



---



---

3 marks

The input signal,  $v_{IN}$ , is shown in Figure 5.

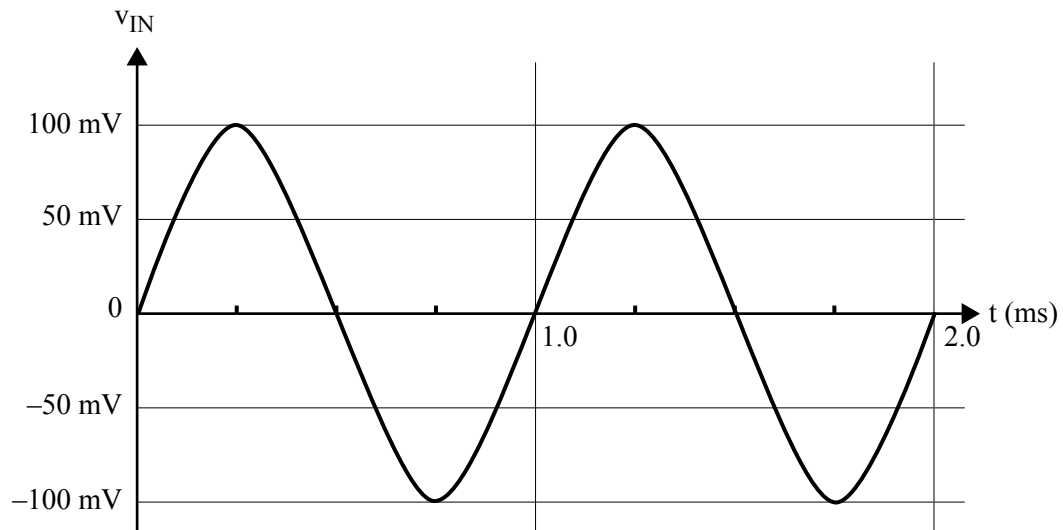
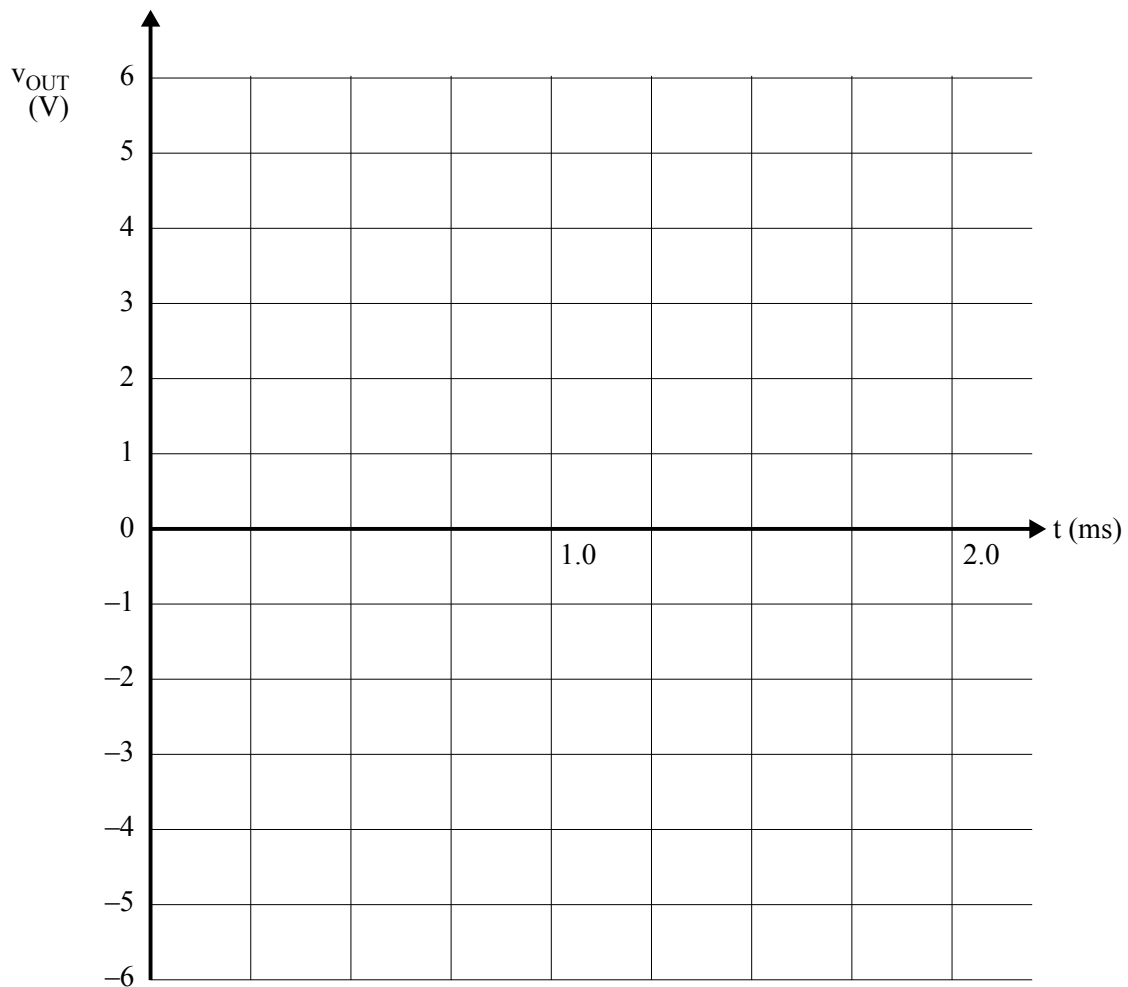

Figure 5

**Question 7**

On the graph below, sketch the output signal as measured at point  $v_{OUT}$ .



3 marks

**Question 8**

It is sometimes necessary to use two transistor amplifiers coupled in series. Such a situation is shown in Figure 6 below.

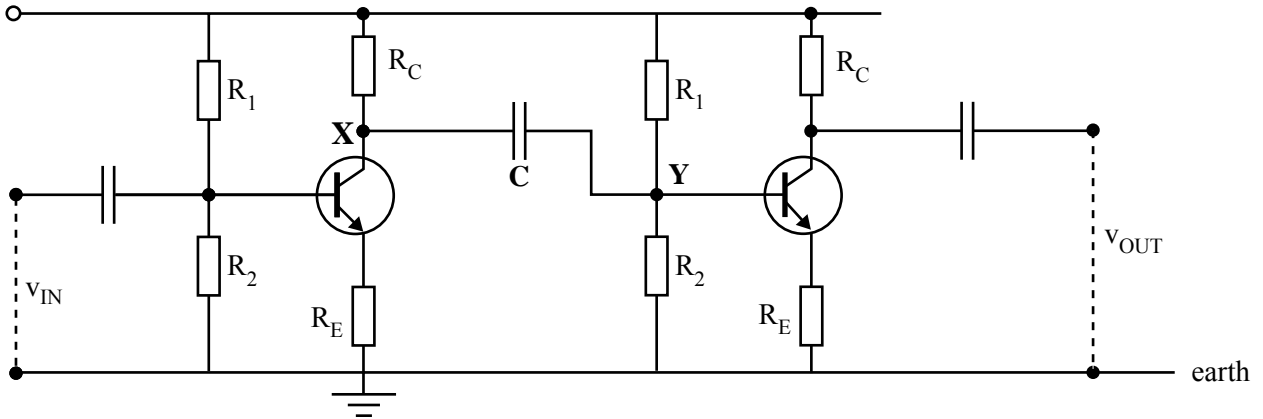

**Figure 6**

In this circuit **X** and **Y** are not directly connected. There is a capacitor in between **X** and **Y**.

Explain why the capacitor is needed.

You should make reference to the correct biasing of the base-emitter.

---

---

---

---

---

---

---

---

---

---

---

---

---

---

---

---

---

---

---

---

---

---

---

---

3 marks

Use the following information to answer Questions 9–11.

A thermistor is a device the resistance of which varies with temperature. The resistance-temperature characteristic for a thermistor is shown in Figure 7.

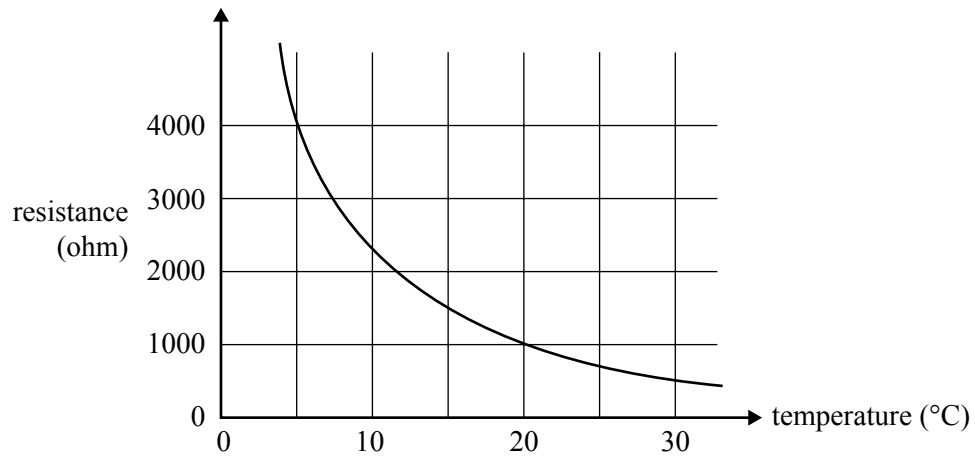

Figure 7

**Question 9**

What is the value of the resistance of the thermistor at 20°C?

$\Omega$
----------

1 mark

The thermistor is incorporated into the control circuit for the refrigeration unit of a coolroom. The circuit is shown in Figure 8 below.

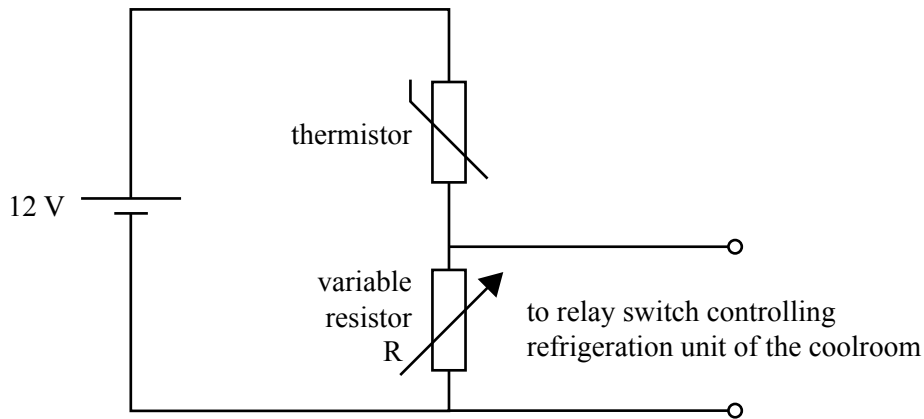

**Figure 8**

The relay switches the refrigeration unit ON when voltage,  $V$ , across variable resistor  $R \geq 4V$  and switches OFF when  $V < 4V$ .

The refrigeration unit must turn on when the temperature of the coolroom rises to, or exceeds,  $5^{\circ}C$ .

**Question 10**

At what value should the resistor  $R$  be set so that the refrigeration unit turns on at this temperature?

You must show your working.

$\Omega$
----------

3 marks

**Question 11**

The coolroom is not cold enough.

To set the temperature lower, should  $R$  be increased or decreased? Explain your answer.

---



---



---



---

3 marks



**SECTION B – Detailed studies****Instructions for Section B**

Select **one** Detailed study.

Answer **all** questions from the Detailed study, in pencil, on the answer sheet provided for multiple-choice questions.

Write the name of your chosen Detailed study on the multiple-choice answer sheet **and** shade the matching box.

Choose the response that is **correct** for the question.

A correct answer scores 2, an incorrect answer scores 0.

Marks will **not** be deducted for incorrect answers.

No marks will be given if more than one answer is completed for any question.

You should take the value of  $g$  to be  $10 \text{ m s}^{-2}$ .

<b>Detailed study</b>	<b>Page</b>
Detailed study 1: Einstein's special relativity .....	26
Detailed study 2: Investigating materials and their use in structures.....	32
Detailed study 3: Further electronics .....	38

### Detailed study 1 – Einstein’s special relativity

Use the following information to answer Questions 1 and 2.

A rocket passes a space station at a speed  $0.80c$  parallel to the side of the space station. There is a circular window on the space station, as shown in Figure 1.

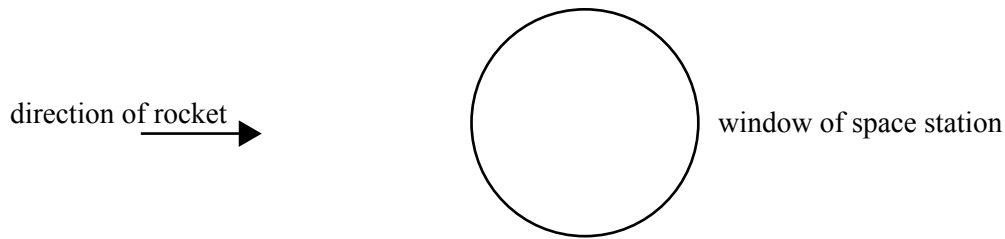

Figure 1

A person inside the passing rocket observes the window.

#### Question 1

Which of the following figures best shows how the window would look to the person on the passing rocket?

A.

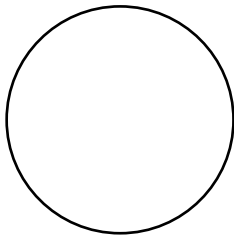

B.

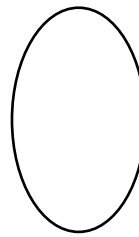

C.

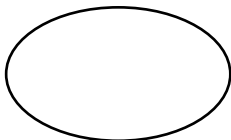

D.

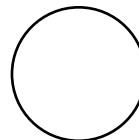

#### Question 2

For which of the following values of the Lorentz factor,  $\gamma$ , would relativistic changes in time, length and mass **not** be observed?

- A. close to 0
- B. significantly less than 1
- C. approximately equal to 1
- D. significantly greater than 1

Use the following information to answer Questions 3 and 4.

Figure 2 below shows Fred in a futuristic train travelling at constant relativistic speed in an easterly direction in a straight line. Fred is halfway between two people, Alan and Bob, who are at opposite ends of the carriage. The train passes a platform. Nancy is standing on the platform.

At the instant that Fred and Nancy are directly opposite each other, Fred sees both Alan and Bob strike matches simultaneously.

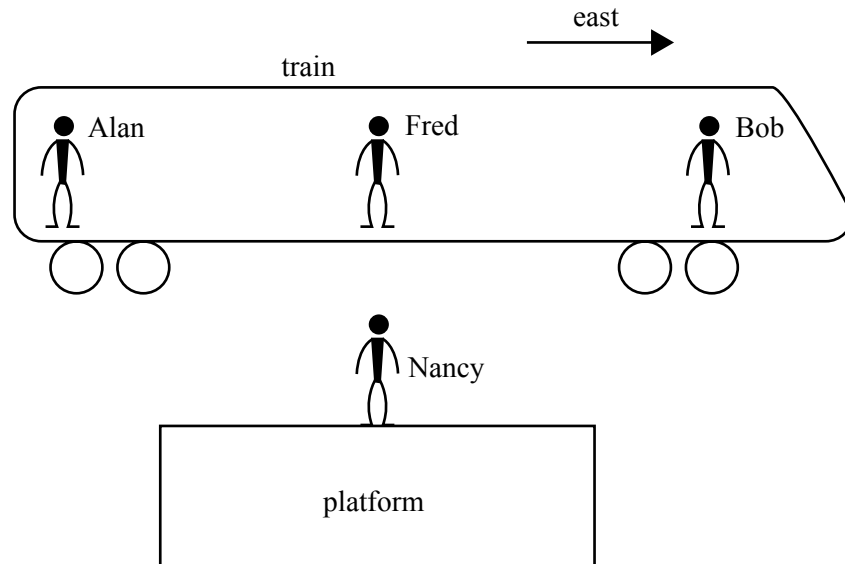

Figure 2

### Question 3

Which one of the following best describes how Nancy sees these two events?

- A. Nancy sees the light from Alan first.
- B. Nancy sees the light from Bob first.
- C. Nancy sees the light from both simultaneously, because both are at equal distances from her when they light the matches.
- D. Nancy sees the light from both simultaneously, because special relativity requires that light travels at the same speed in all frames of reference.

### Question 4

Fred measures the carriage he is travelling in to be 20 m long. Nancy has measured the platform she is standing on to be 10 m long. The train rushes past at such a speed that Nancy sees the carriage and the platform to be the same length.

How fast was the train moving?

- A. 0.50 c
- B. 0.75 c
- C. 0.87 c
- D. 0.97 c

*Use the following information to answer Questions 5 and 6.*

In 1887 Michelson and Morley conducted a famous experiment using light.

**Question 5**

The aim of this experiment was to

- A. accurately measure the speed of light.
- B. show that light was a wave by observing interference effects.
- C. measure the speed of Earth through the ether.
- D. prove that light was an electromagnetic wave as predicted by James Clerk Maxwell.

**Question 6**

The results of the Michelson–Morley experiment supported Einstein’s later postulates of the special theory of relativity.

Which one of the following is a postulate of Einstein’s theory that was supported by the Michelson–Morley experiment?

- A.  $E = m c^2$ .
  - B. The speed of light has a constant value for all observers.
  - C. Light is a wave.
  - D. The speed of light depends on the speed of the observer’s frame of reference.
-

Use the following information to answer Questions 7 and 8.

Trung and Mary are driving along a road at  $40 \text{ m s}^{-1}$  in the same direction. A stationary siren is situated between them. The speed of sound in air is  $340 \text{ m s}^{-1}$ . The situation is shown in Figure 3.

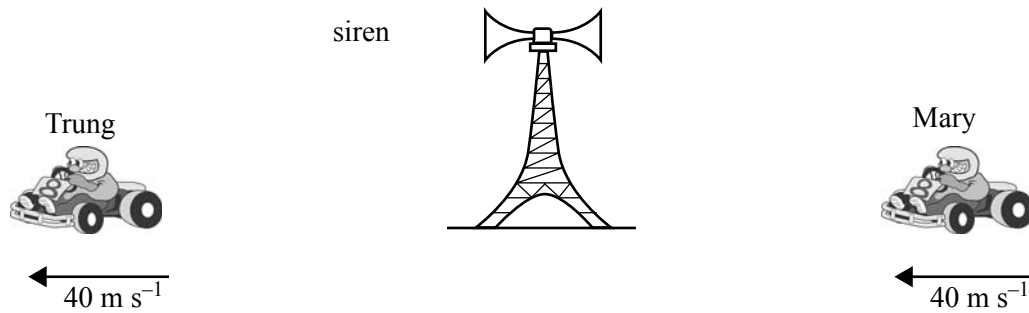

Figure 3

### Question 7

Which one of the following gives the speed of sound from the siren, in  $\text{m s}^{-1}$ , as measured by Trung and Mary?

	Trung	Mary
A.	340	340
B.	300	380
C.	380	300
D.	320	320

A similar situation now occurs in space, except that Trung and Mary are travelling in two rocket ships in the same direction at  $0.2 c$ . Instead of the siren, a stationary space station between them is emitting light of speed  $3.0 \times 10^8 \text{ m s}^{-1}$  in all directions, as shown in Figure 4.

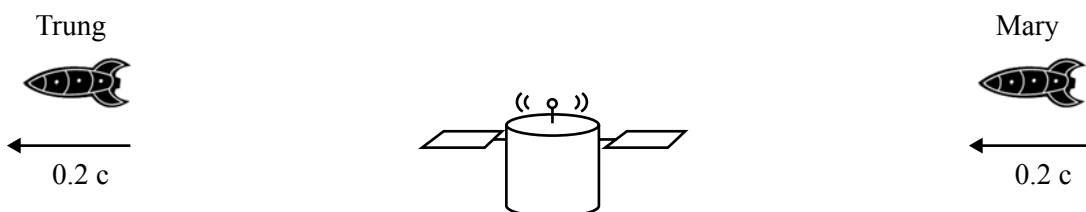

Figure 4

### Question 8

Which one of the following gives the speed of light from the space station as measured by Trung and Mary?

	Trung	Mary
A.	$1.2 c$	$0.8 c$
B.	$c$	$c$
C.	$0.8 c$	$1.2 c$
D.	$1.1 c$	$1.1 c$

**Question 9**

Roger is in a spacecraft travelling at constant speed, passing Bridget who is stationary. Roger is holding a ruler. Roger measures its length to be 1.0 m. The ruler can be seen by Bridget through a window as the spacecraft passes.

Bridget measures the length of the ruler to be 0.8 m.

Which one of the following gives the proper length of the ruler?

- A. 0.20 m
  - B. 0.80 m
  - C. 1.0 m
  - D. 1.2 m
- 

**Question 10**

An electron with an initial speed of  $0.99c$  enters an accelerator, which increases the electron's speed and energy.

Which one of the following best describes the effect of the accelerator on the electron's speed and energy?

- A. The speed increases substantially, the energy increases substantially.
  - B. The speed increases slightly, the energy increases substantially.
  - C. The speed increases slightly, the energy increases slightly.
  - D. The speed increases substantially, the energy increases slightly.
-

Use the following information to answer Questions 11 and 12.

An electron with a Lorentz factor of 4 travels in a straight line a distance of 600 m as measured in the laboratory frame of reference.

**Question 11**

Which one of the following best gives the speed of the electron?

- A. 0.25 c
- B. 0.94 c
- C. 0.97 c
- D. 0.99 c

**Question 12**

As measured in the electron's frame of reference, what would be the approximate length of the linear section?

- A. 2 400 m
  - B. 600 m
  - C. 300 m
  - D. 150 m
- 

**Question 13**

In the fusion process, a proton of rest mass  $1.673 \times 10^{-27}$  kg and a neutron of rest mass  $1.675 \times 10^{-27}$  kg combine to form a deuterium nucleus of rest mass  $3.344 \times 10^{-27}$  kg, with a release of energy.

According to Einstein's postulate of the equivalence of mass and energy, which one of the following is the best estimate of the energy released in this interaction?

- A.  $1.2 \times 10^{-21}$  J
- B.  $3.6 \times 10^{-13}$  J
- C.  $4.0 \times 10^{-3}$  J
- D.  $3.6 \times 10^{14}$  J

## Detailed study 2 – Investigating materials and their use in structures

Use the following information to answer Questions 1–7.

Since ancient times, stone columns have been used to support beams and arches on which the upper parts of walls and ceilings rest.

Persepolis (Figure 1) was an ancient capital of the Persian Empire.



**Figure 1**

A typical stress-strain graph for stone is shown in Figure 2. The points of failure are indicated by crosses (X).

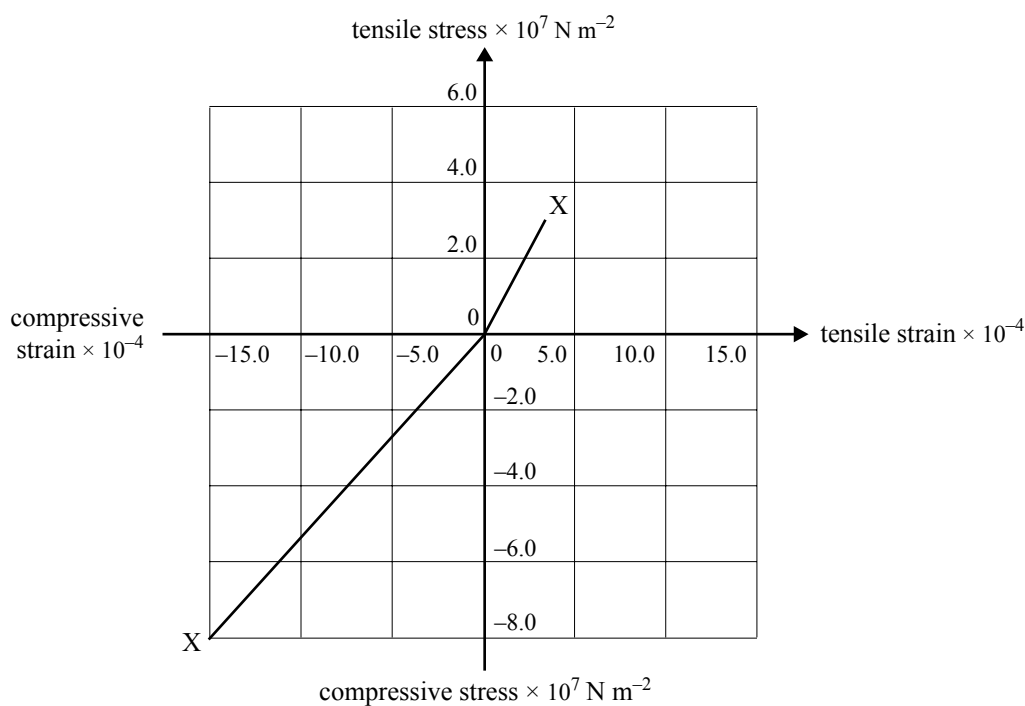

**Figure 2**

### Question 1

What is the value of Young's modulus for stone under compression?

- A.  $1.9 \times 10^{-11} \text{ N m}^{-2}$
- B.  $1.9 \text{ N m}^{-2}$
- C.  $5.3 \text{ N m}^{-2}$
- D.  $5.3 \times 10^{10} \text{ N m}^{-2}$



**Question 2**

From the graph, stone can best be described as

- A. ductile.
- B. brittle.
- C. flexible.
- D. plastic.

The largest building in Persepolis was the Apadana, an audience hall. It had a roof supported by tall stone columns.

Assume each of the columns was 20.0 m high with a uniform cross-sectional area of 1.50 m<sup>2</sup>.

**Question 3**

Which one of the following gives the best estimate of the largest downward force such a column can withstand without breaking?

- A.  $1.2 \times 10^8$  N
- B.  $5.3 \times 10^7$  N
- C.  $2.7 \times 10^6$  N
- D.  $4.0 \times 10^6$  N

**Question 4**

Which one of the following best gives **the strain energy per unit volume** stored in this stone material up to the point of fracture in compression?

- A.  $6.0 \times 10^4$  J m<sup>-3</sup>
- B.  $1.2 \times 10^5$  J m<sup>-3</sup>
- C.  $6.0 \times 10^8$  J m<sup>-3</sup>
- D.  $1.2 \times 10^9$  J m<sup>-3</sup>

**Question 5**

By which one of the following factors would you multiply your answer to the previous question to calculate **the total strain energy stored** in the column up to the point of fracture?

- A. 1.5
- B. 20
- C. 30
- D. 45

Each column is 20.00 m long when not under load. With a particular load, the strain is  $5.00 \times 10^{-4}$ .

**Question 6**

Which one of the following gives the best estimate of the height of the column when under this load?

- A. 19.00 m
- B. 19.90 m
- C. 19.99 m
- D. 20.01 m

**Question 7**

Which one of the following statements is true of stone as a material for use in structures?

- A. Stone is more ductile in tension than compression.
  - B. Stone is stronger in tension than compression.
  - C. Stone is stiffer in tension than compression.
  - D. Stone is more dense in tension than compression.
- 

*Use the following information to answer Questions 8 and 9.*

Figure 3 shows one side of a bridge structure. Each of the beams making up the structure has a mass of 200 kg.

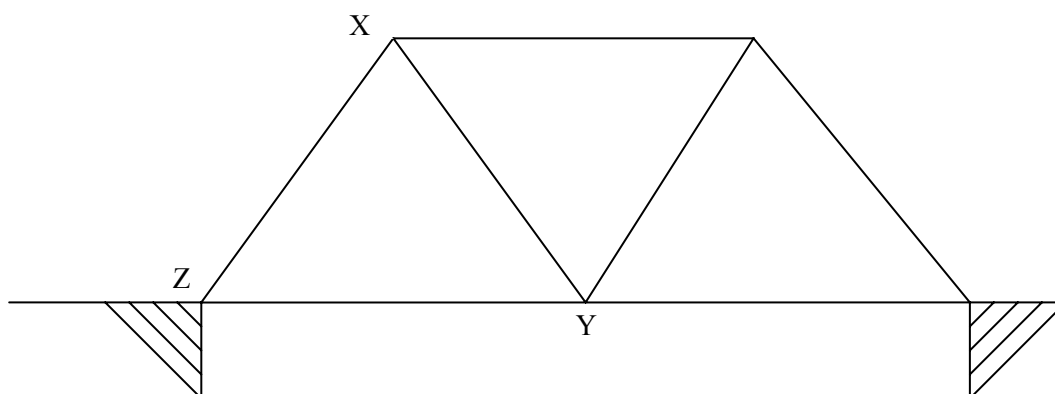

**Figure 3**

**Question 8**

Which one of the following best describes the stress in beam XY?

- A. It is in tension.
- B. It is in compression.
- C. It is neutral.
- D. It depends on whether there is a load on the bridge or not.

**Question 9**

Which one of the following best describes the stress in beam YZ?

- A. It is in tension.
  - B. It is in compression.
  - C. It is neutral.
  - D. It depends on whether there is a load on the bridge or not.
-

Figure 4 shows the stress-strain graph for two types of steel – P and Q.

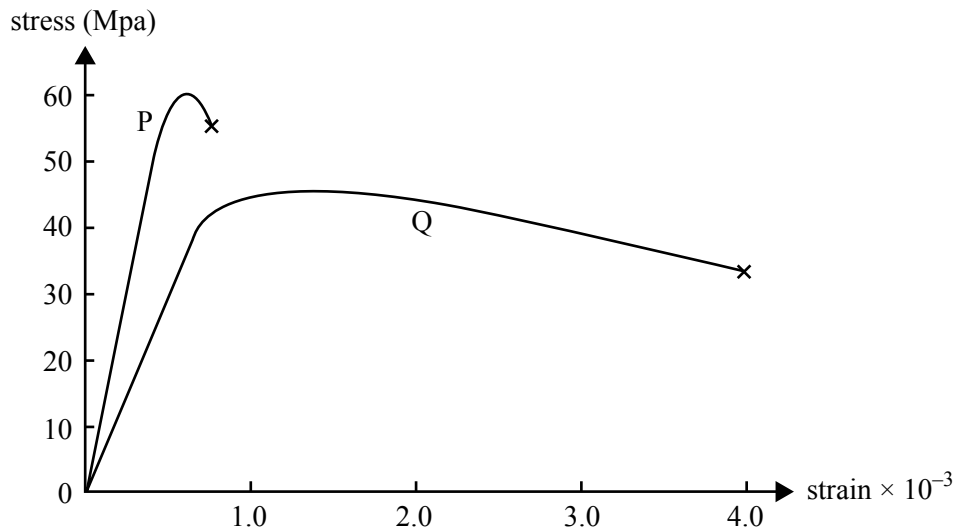

**Figure 4**

**Question 10**

Which one of the following best describes the relative properties of P and Q?

- A. P has greater stiffness and lower toughness than Q.
- B. P has greater stiffness and greater toughness than Q.
- C. P has lower stiffness and lower toughness than Q.
- D. P has lower stiffness and greater toughness than Q.

Use the following information to answer Questions 11–13.

Figure 5 shows the reinforced concrete beam, XZ, of a tourist lookout. The mass of the beam is 4 000 kg.

The beam rests (with no fixed connection) on two pillars at X and Y.

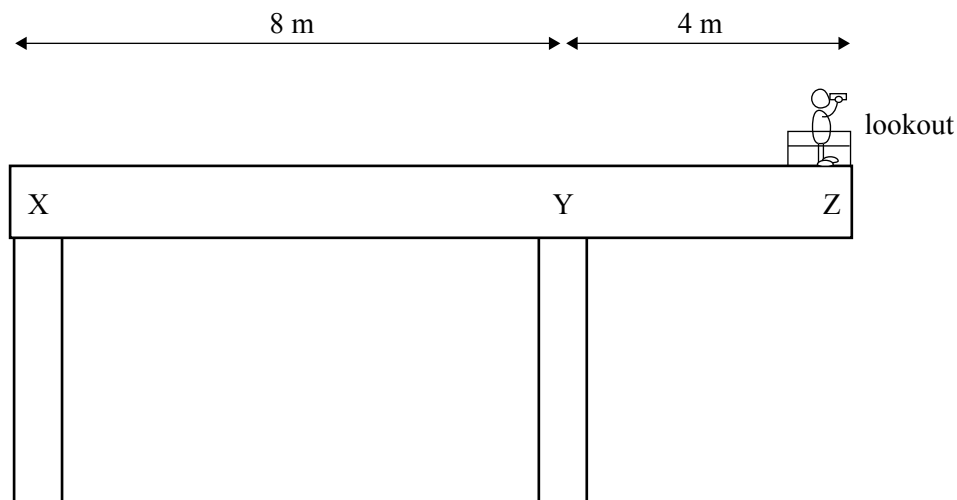

Figure 5

**Question 11**

With no-one standing on the lookout, which one of the following best gives the force of the beam on the support at X?

- A. 1 000 N
- B. 2 000 N
- C. 10 000 N
- D. 20 000 N

**Question 12**

Which one of the following best gives the maximum load that can be placed at point Z (assume load concentrated at end) without the beam tilting?

- A. 1 000 kg
- B. 2 000 kg
- C. 4 000 kg
- D. 10 000 kg

Reinforcing steel rods (shown by the bold lines) are used in the concrete beam in the lookout as shown in Figure 5.

**Question 13**

Which one of the diagrams best shows the placement of these steel rods?

**A.**

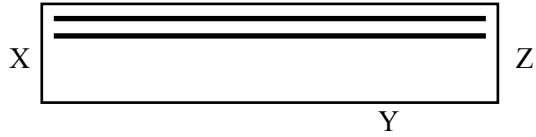

**B.**

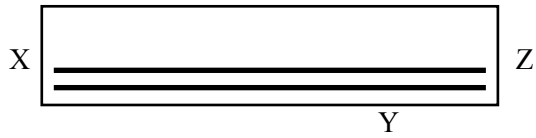

**C.**

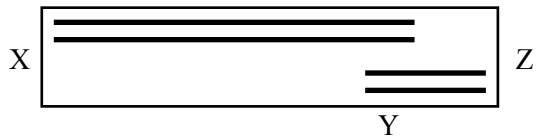

**D.**

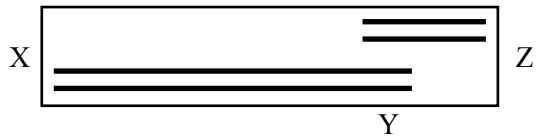

not to scale

### Detailed study 3 – Further electronics

A student is designing, constructing and testing a DC power supply. She begins by studying and testing a number of possible components separately (Questions 1–7).

In Questions 1–3, she studies the operation of a capacitor using an RC circuit. To test the capacitor, the student connects the following circuit, as shown in Figure 1. The battery supplies 10 V DC.

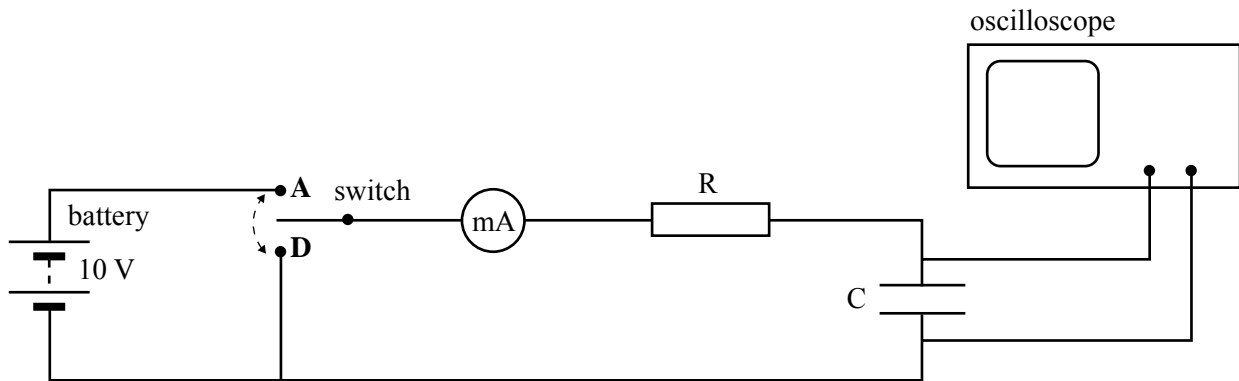

Figure 1

#### Question 1

C is a  $100 \mu\text{F}$  capacitor and R is a  $5 \text{ k}\Omega$  resistor.

What is the time constant,  $\tau$ , of this RC circuit?

- A. 5 000 s
- B. 5.0 s
- C. 0.50 s
- D. 0.0050 s

Using the same circuit but with a different capacitor, the RC circuit is found to have a time constant of  $\tau = 6$  s. With the capacitor initially discharged, the switch is moved to position A.

**Question 2**

Which one of the graphs best shows the voltage against time across the capacitor as measured by the oscilloscope?

**A.**

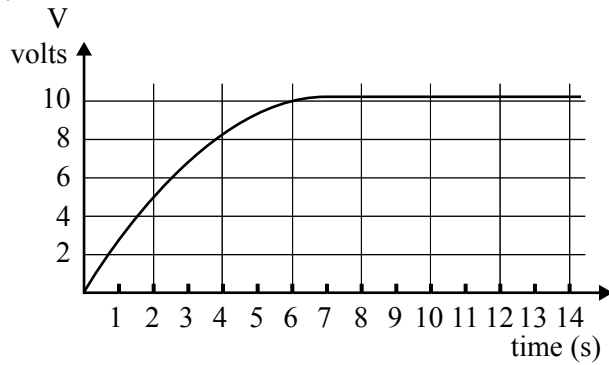

**B.**

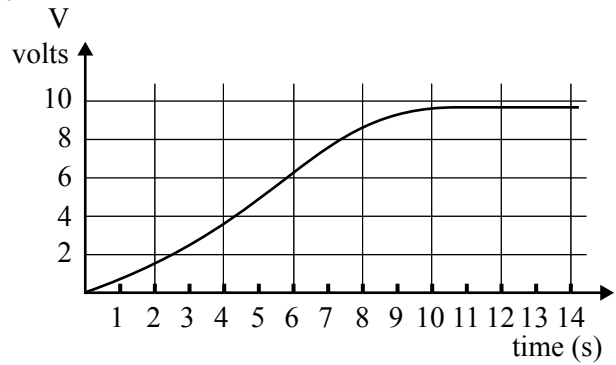

**C.**

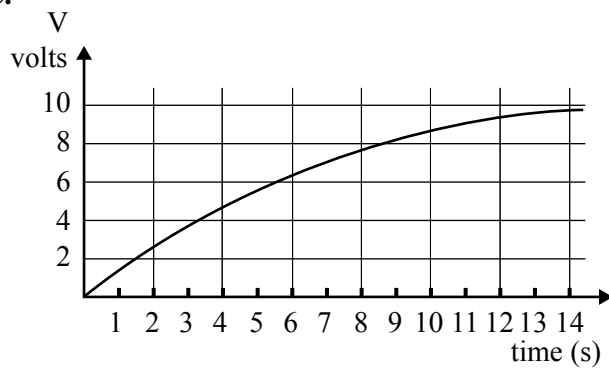

**D.**

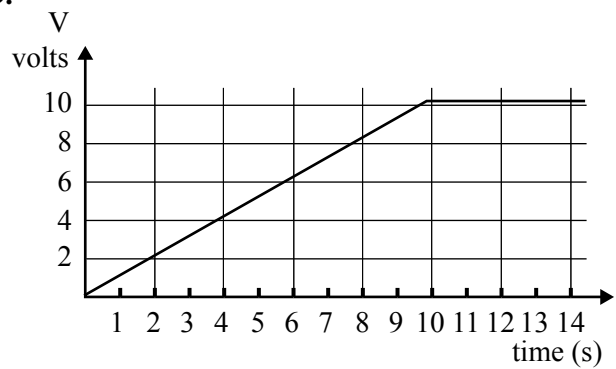

With the capacitor fully charged, the switch is moved to position D.

**Question 3**

Which one of the graphs best shows the voltage against time across the capacitor as measured by the oscilloscope?

**A.**

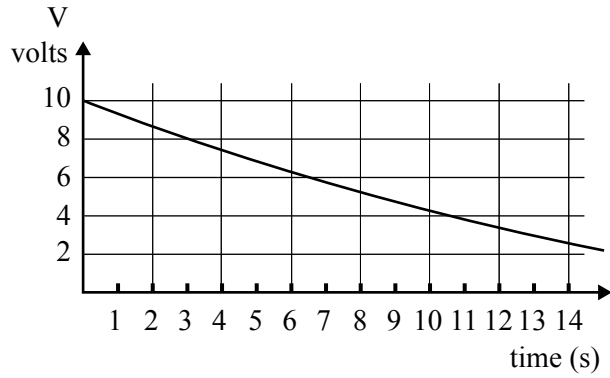

**B.**

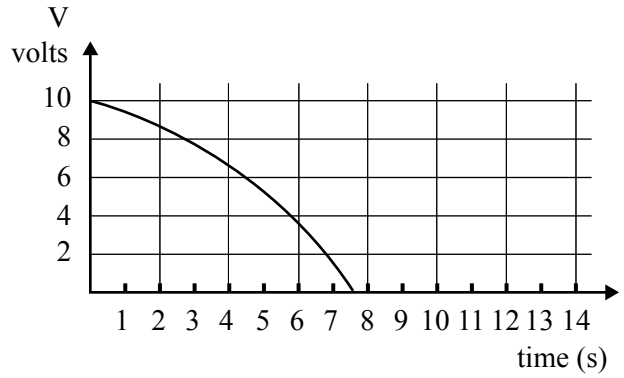

**C.**

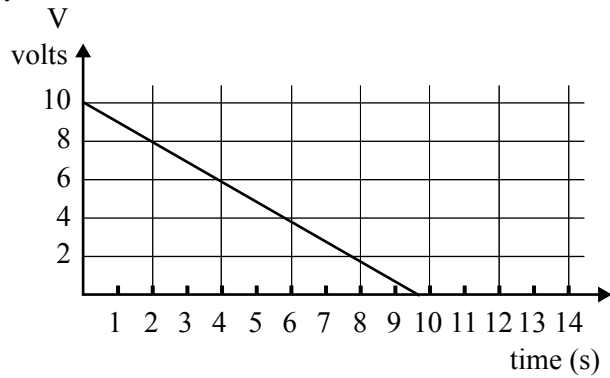

**D.**

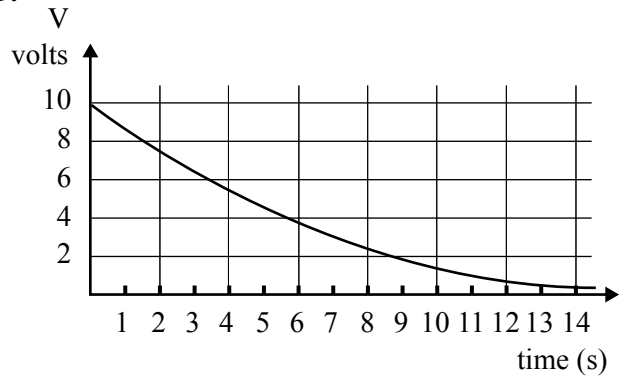



The student next considers a bridge rectifier (Questions 4 and 5).

The bridge rectifier is shown in Figure 2.

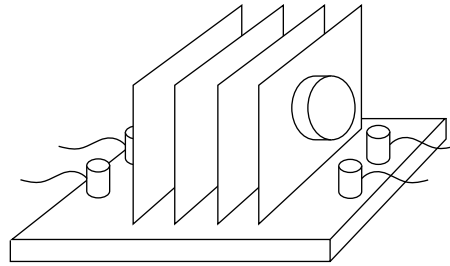

**Figure 2**

Each of the diodes of the bridge rectifier is mounted on a separate copper plate.

**Question 4**

The purpose of these plates is to

- A. shield each diode from the electric field of the other diodes.
- B. shield the bridge rectifier from interference from outside electric fields.
- C. dissipate heat generated in the diodes.
- D. warm the diodes to keep them at a higher temperature in order to operate correctly.

**Question 5**

Which one of the following circuits best shows how the diodes should be arranged for the bridge rectifier to operate correctly?

A.

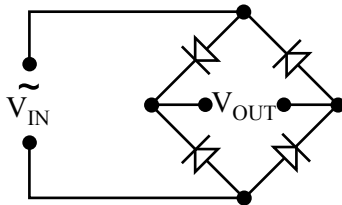

B.

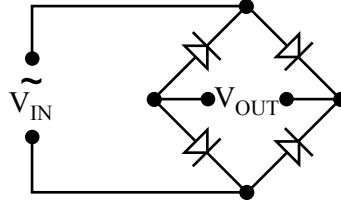

C.

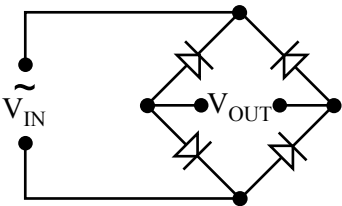

D.

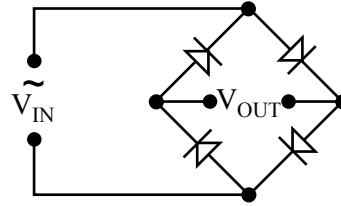

The student now studies a Zener diode (Questions 6 and 7).

Figure 3 shows the current-voltage characteristics of a Zener diode which could be used as the voltage regulator in a power supply.

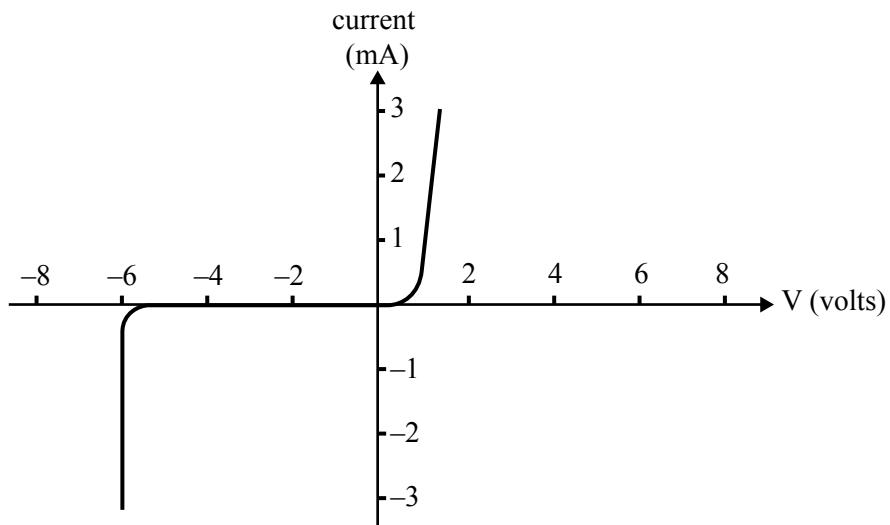
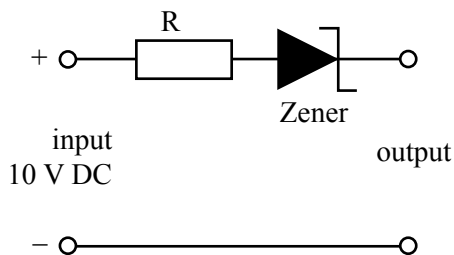

Figure 3

**Question 6**

Which one of the following circuits best shows the Zener diode correctly set up to give a 6 V regulated output?

A.



B.

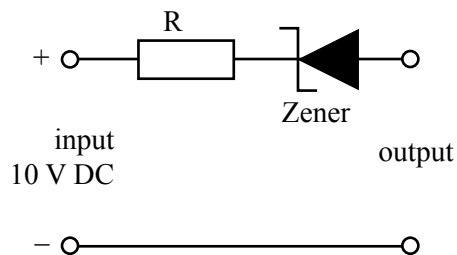

C.

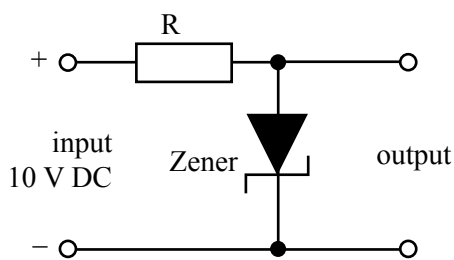

D.

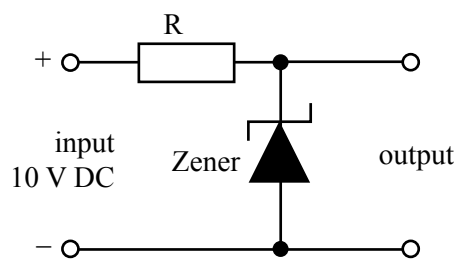

A transformer is required to provide 10 V AC<sub>RMS</sub> output from 240 V AC<sub>RMS</sub> input.

**Question 7**

Which one of the ratios of turns,  $N_{\text{primary}} : N_{\text{secondary}}$ , would provide the correct secondary voltage output?

- A. 4800 : 200
- B. 200 : 4800
- C. 4800 : 282
- D. 4800 : 141

The student begins to assemble the power supply. The transformer is set to give  $10\text{ V}_{\text{RMS}}$  AC  $50\text{ Hz}$  output.

As she completes each stage, **before** connecting the following stage, she tests the output of that stage using a  $10\ \Omega$  load resistor and an oscilloscope.

In Questions 8–11 the oscilloscope is set at  $4\text{ V/cm}$  on the vertical scale, and  $5.0\text{ ms/cm}$  on the horizontal scale.

In Questions 8–11 select which of the displays she would see on the oscilloscope.

She begins with just the transformer, with an output of  $10\text{ V}_{\text{RMS}}$  AC,  $50\text{ Hz}$ , as shown in Figure 4.

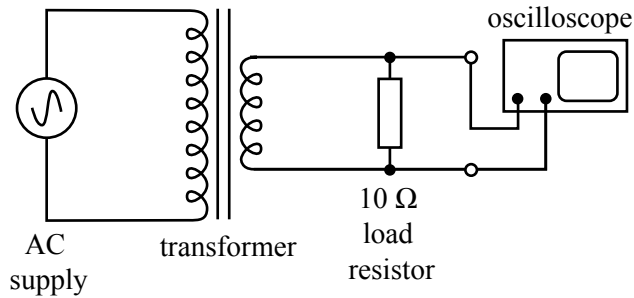
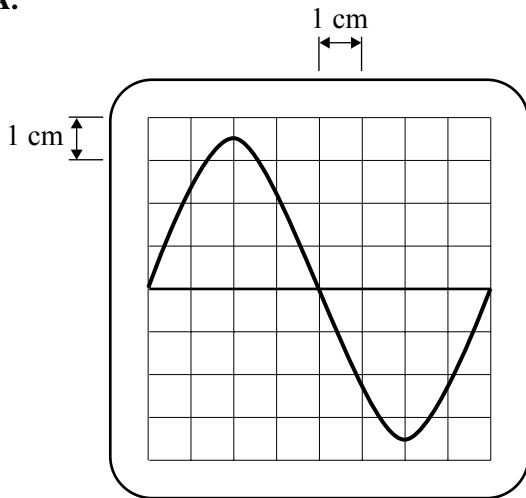

Figure 4

### Question 8

Which one of the following best shows the display she would see on the oscilloscope?

A.



B.

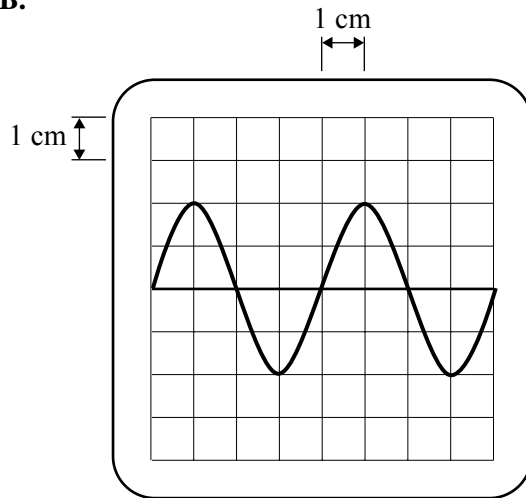

C.

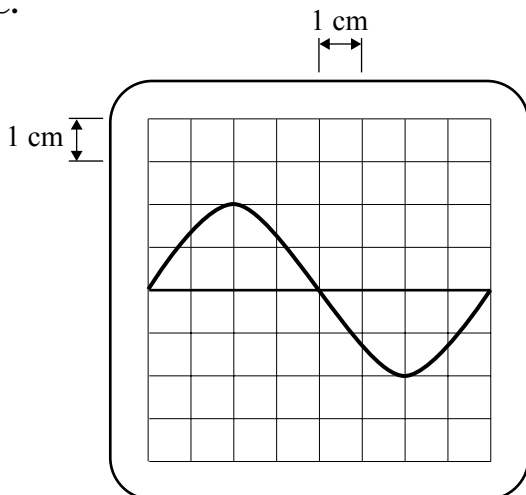

D.

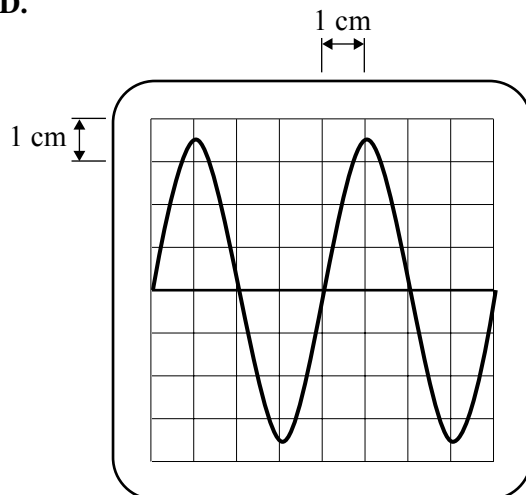

She now connects the fullwave diode bridge rectifier, as shown in Figure 5.

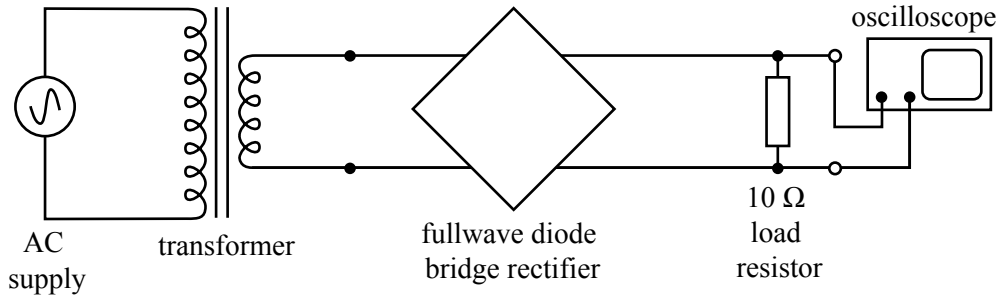
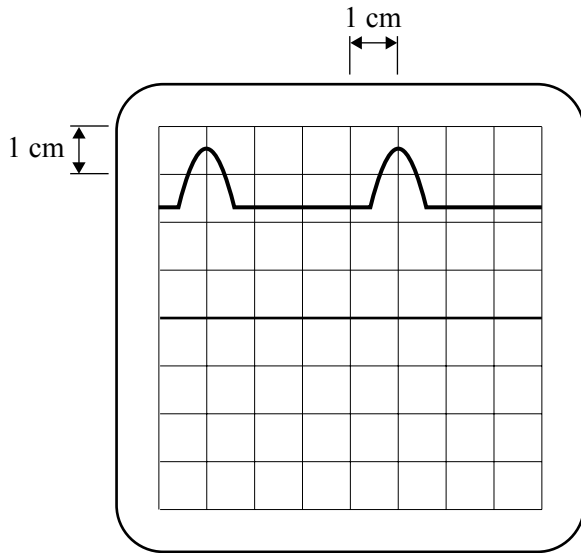

Figure 5

**Question 9**

Which one of the following best shows the display she would now see on the oscilloscope?

A.



B.

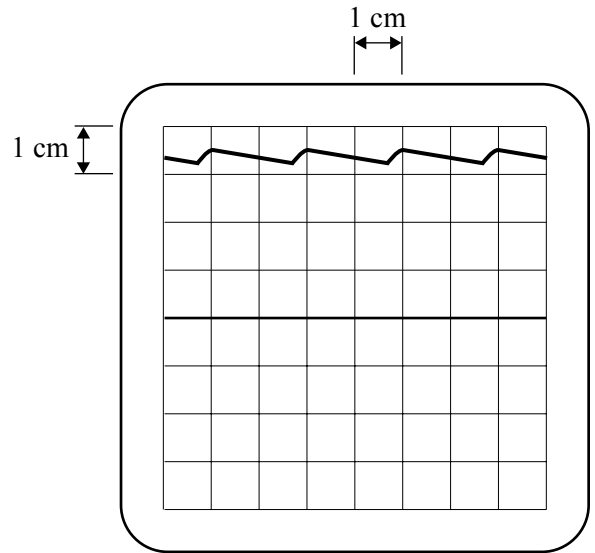

C.

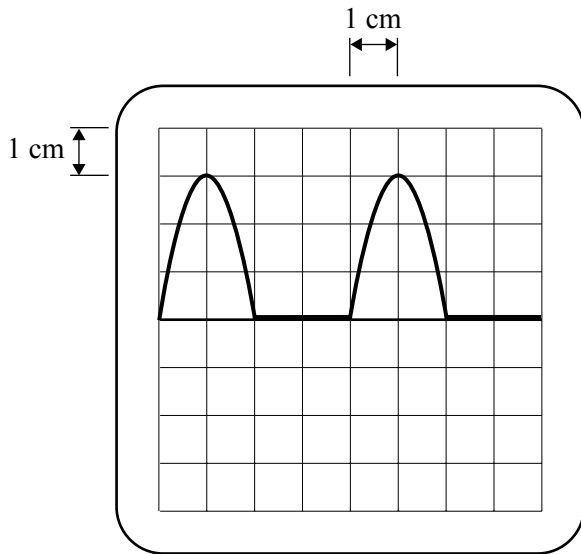

D.

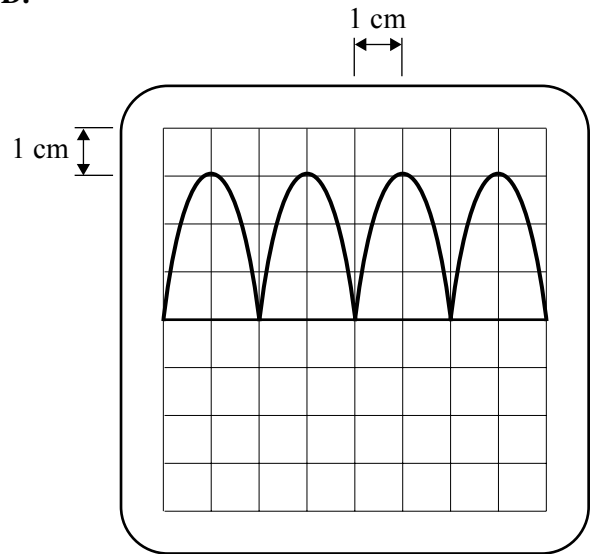

A 400  $\mu\text{F}$  smoothing capacitor is now installed in the circuit as shown in Figure 6.

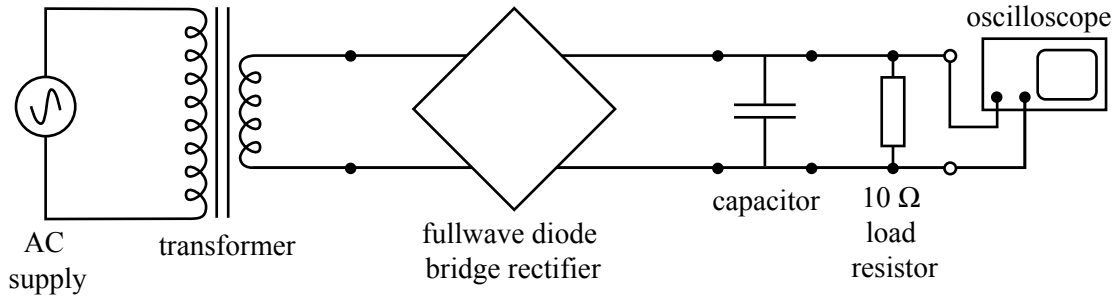
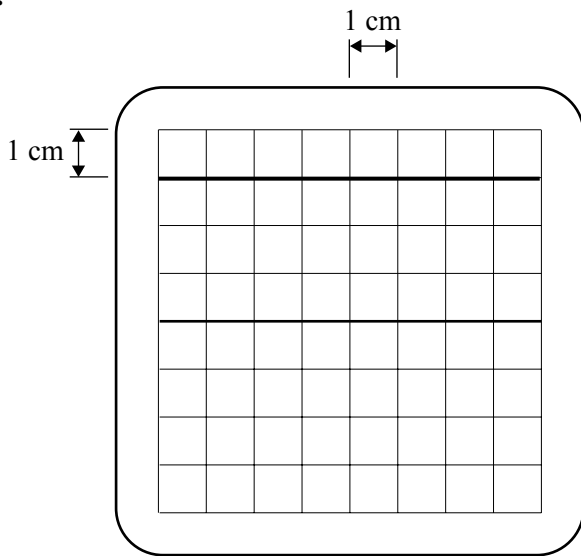

Figure 6

**Question 10**

Which one of the following best shows the display the student would now see on the oscilloscope?

A.



B.

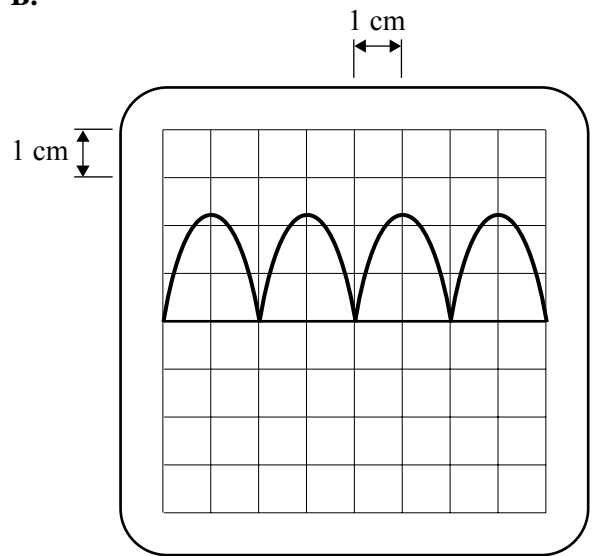

C.

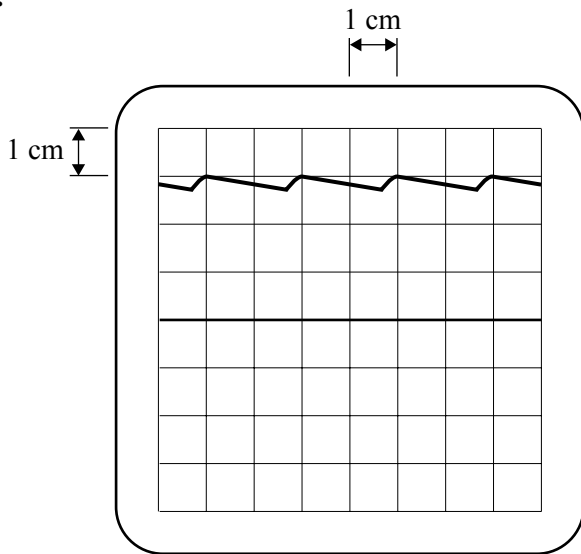

D.

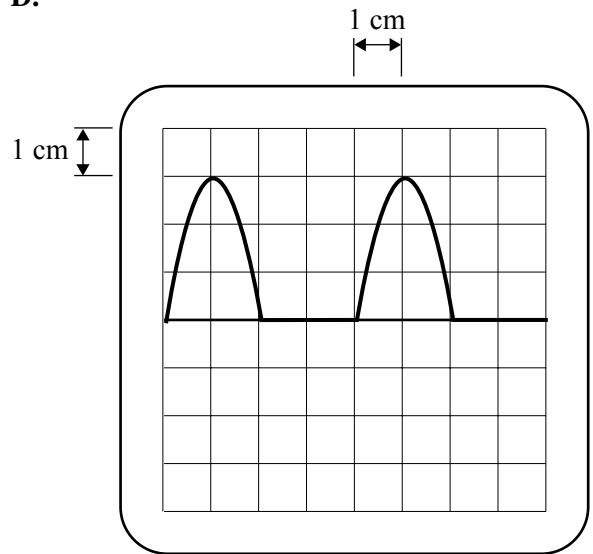

She now inserts an Integrated Circuit (IC) voltage regulator into the circuit, as shown in Figure 7.

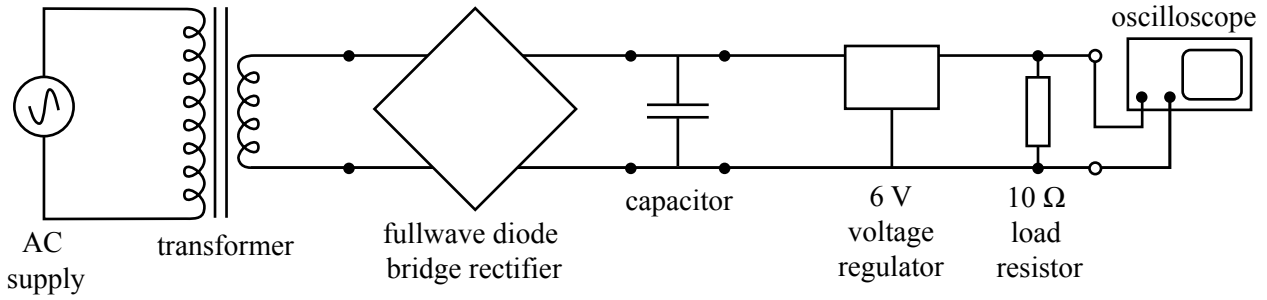
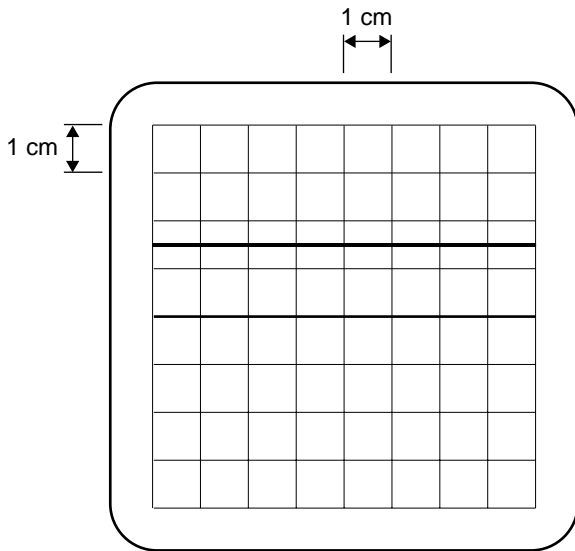

**Figure 7**

**Question 11**

Which one of the following best shows the display she would now see on the oscilloscope?

**A.**



**B.**

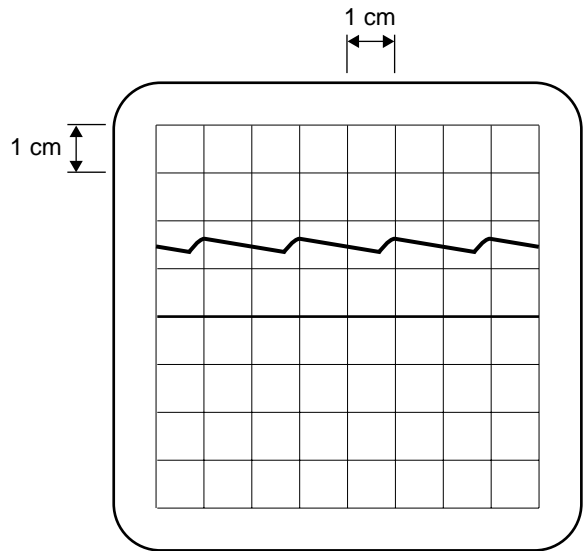

**C.**

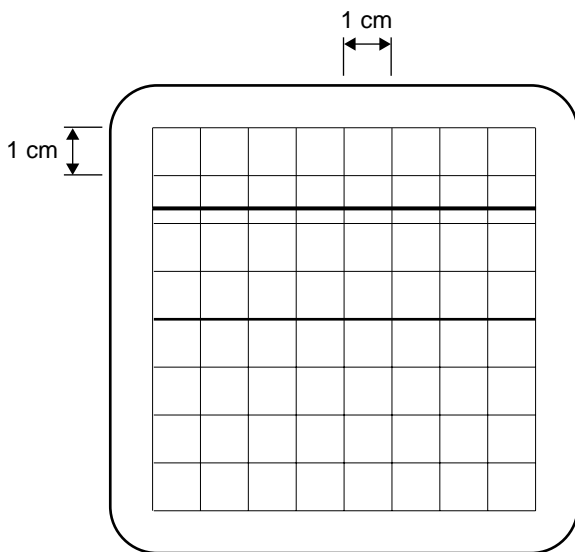

**D.**

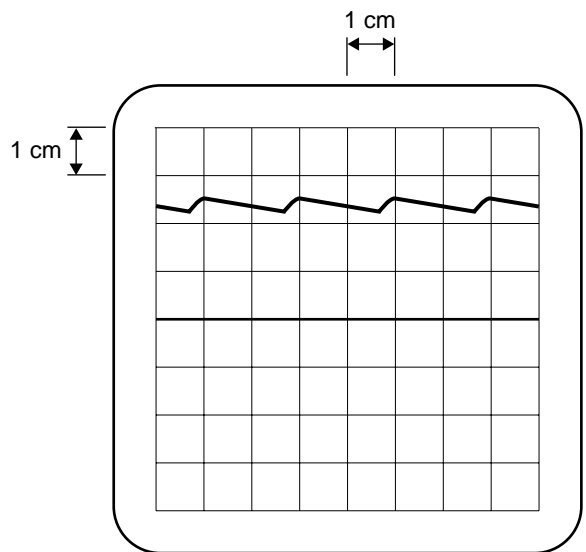

**Question 12**

With the complete regulated power supply as shown in Figure 7 now operating, which one of the following would best give the approximate power being dissipated in the  $10\ \Omega$  load resistor?

- A. 0.1 W
- B. 1.0 W
- C. 3.6 W
- D. 36 W

**Question 13**

She finds that the ripple voltage is unacceptably high.

Which one of the following changes to the power supply would best reduce the ripple voltage at the output, while keeping the power supply operating correctly?

- A. Increase the transformer output to 14 V.
- B. Replace the voltage regulator with one with an output of 8 V.
- C. Replace the  $400\ \mu\text{F}$  capacitor with a  $10\ 000\ \mu\text{F}$  capacitor.
- D. Replace the  $400\ \mu\text{F}$  capacitor with a  $10\ \mu\text{F}$  capacitor.

# **PHYSICS**

## **Written examination 1**

### **DATA SHEET**

#### **Directions to students**

Detach this data sheet before commencing the examination.

This data sheet is provided for your reference.



1	velocity; acceleration	$v = \frac{\Delta x}{\Delta t}; \quad a = \frac{\Delta v}{\Delta t}$
2	equations for constant acceleration	$v = u + at$ $x = ut + \frac{1}{2}at^2$ $v^2 = u^2 + 2ax$ $x = \frac{1}{2}(v + u)t$
3	Newton's second law	$F = ma$
4	circular motion	$a = \frac{v^2}{r} = \frac{4\pi^2 r}{T^2}$
5	Hooke's law	$F = -kx$
6	elastic potential energy	$\frac{1}{2}kx^2$
7	gravitational potential energy near the surface of the Earth	$mgh$
8	kinetic energy	$\frac{1}{2}mv^2$
9	Newton's law of universal gravitation	$F = G \frac{M_1 M_2}{r^2}$
10	gravitational field	$g = G \frac{M}{r^2}$
11	stress	$\sigma = \frac{F}{A}$
12	strain	$\varepsilon = \frac{\Delta L}{L}$
13	Young's modulus	$E = \frac{\text{stress}}{\text{strain}}$
14	transformer action	$\frac{V_1}{V_2} = \frac{N_1}{N_2}$
15	AC voltage and current	$V_{\text{RMS}} = \frac{1}{2\sqrt{2}} V_{\text{P-P}} \quad I_{\text{RMS}} = \frac{1}{2\sqrt{2}} I_{\text{P-P}}$
16	voltage; power	$V = RI \quad P = VI$

17	resistors in series	$R_T = R_1 + R_2$
18	resistors in parallel	$\frac{1}{R_T} = \frac{1}{R_1} + \frac{1}{R_2}$
19	capacitors	time constant : $\tau = RC$
20	Lorentz factor	$\gamma = \frac{1}{\sqrt{1 - v^2/c^2}}$
21	time dilation	$t = t_0 \gamma$
22	length contraction	$L = L_0 / \gamma$
23	relativistic mass	$m = m_0 \gamma$
24	universal gravitational constant	$G = 6.67 \times 10^{-11} \text{ N m}^2 \text{ kg}^{-2}$
25	mass of Earth	$M_E = 5.98 \times 10^{24} \text{ kg}$
26	radius of Earth	$R_E = 6.37 \times 10^6 \text{ m}$
27	mass of the electron	$m_e = 9.1 \times 10^{-31} \text{ kg}$
28	charge on the electron	$q = -1.6 \times 10^{-19} \text{ C}$
29	speed of light	$c = 3.0 \times 10^8 \text{ m s}^{-1}$

#### Prefixes/Units

p = pico =  $10^{-12}$

n = nano =  $10^{-9}$

$\mu$  = micro =  $10^{-6}$

m = milli =  $10^{-3}$

k = kilo =  $10^3$

M = mega =  $10^6$

G = giga =  $10^9$

t = tonne =  $10^3 \text{ kg}$

**END OF DATA SHEET**