



Victorian Certificate of Education 2003

SUPERVISOR TO ATTACH PROCESSING LABEL HERE

STUDENT NUMBER

Letter

Figures

Words

CHEMISTRY

Written examination 2

Wednesday 12 November 2003

Reading time: 9.00 am to 9.15 am (15 minutes)

Writing time: 9.15 am to 10.45 am (1 hour 30 minutes)

QUESTION AND ANSWER BOOK

Structure of book

Section	Number of questions	Number of questions to be answered	Number of marks	Suggested times (minutes)
A	20	20	20	25
B	8	8	55	65
			Total 75	90

- Students are permitted to bring into the examination room: pens, pencils, highlighters, erasers, sharpeners, rulers, an approved graphics calculator (memory cleared) and/or one scientific calculator.
- Students are NOT permitted to bring into the examination room: blank sheets of paper and/or white out liquid/tape.

Materials supplied

- Question and answer book of 17 pages, with a detachable data sheet in the centrefold.
- Answer sheet for multiple-choice questions.

Instructions

- Detach the data sheet from the centre of this book during reading time.
- Write your **student number** in the space provided above on this page.
- Check that your **name** and **student number** as printed on your answer sheet for multiple-choice questions are correct, **and** sign your name in the space provided to verify this.
- All written responses must be in English.

At the end of the examination

- Place the answer sheet for multiple-choice questions inside the front cover of this book.

Students are NOT permitted to bring mobile phones and/or any other electronic communication devices into the examination room.

SECTION A – Multiple-choice questions**Instructions for Section A**

Answer **all** questions in pencil on the answer sheet provided for multiple-choice questions.

Choose the response that is **correct** or that **best answers** the question.

A correct answer scores 1, an incorrect answer scores 0.

Marks will **not** be deducted for incorrect answers.

No marks will be given if more than one answer is completed for any question.

Section A is worth approximately 27 per cent of the marks available.

Question 1

947 J of energy is required to raise the temperature of 125 g of stainless steel by 15.7°C.

The specific heat capacity of the stainless steel, in $\text{J g}^{-1}\text{C}^{-1}$, is

- A. 8.41×10^{-3}
- B. 0.483
- C. 7.54
- D. 119

Questions 2 and 3 refer to the following information.

The relative enthalpies, on an arbitrary scale, of the reactants and products of a chemical reaction, are represented on the following diagram.

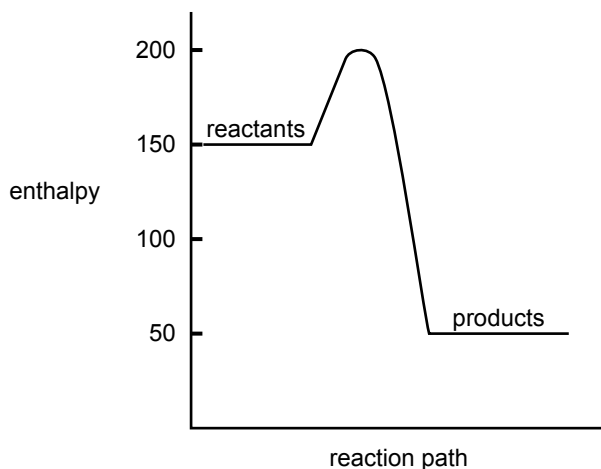
**Question 2**

The numerical value of enthalpy change, ΔH , for the forward reaction, is

- A. +150
- B. +50
- C. -50
- D. -100

Question 3

The numerical value of the activation energy for the reverse reaction is

- A. +150
- B. +50
- C. -50
- D. -100

Question 4

The combustion of octane can be represented by the equation

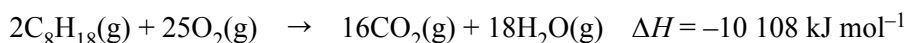

The energy produced, in kJ, by the complete oxidation of 45 kg of octane is

- A. 2.0×10^3
- B. 4.0×10^3
- C. 2.0×10^6
- D. 4.0×10^6

Questions 5 and 6 refer to the following information.

A student electrolyses a 0.1 M aqueous solution of sodium chloride. A colourless, odourless gas is evolved at one electrode. A second colourless, odourless gas is evolved at the other electrode.

Question 5

The gases evolved at the positive and negative electrodes are

Positive electrode	Negative electrode
A. oxygen	hydrogen
B. hydrogen	oxygen
C. chlorine	hydrogen
D. hydrogen	chlorine

Question 6

During this electrolysis, the pH of the solution will

- A. decrease around the cathode and increase around the anode.
- B. increase around the cathode and decrease around the anode.
- C. decrease at both electrodes.
- D. increase at both electrodes.

Question 7

The energy released in a chemical reaction is **directly** converted to electrical energy in a

- A. solar cell.
- B. electrolytic cell.
- C. fossil-fuel power station.
- D. hydrogen/oxygen fuel cell.

Question 8

The cell reaction when a car battery releases energy is given by the equation below.

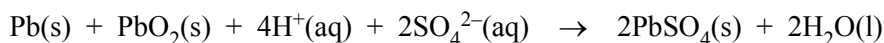

When the battery is being **recharged**, the reaction that occurs at the negative electrode is

- A. $\text{Pb}(\text{s}) + \text{SO}_4^{2-}(\text{aq}) \rightarrow \text{PbSO}_4(\text{s}) + 2\text{e}^-$
- B. $\text{PbO}_2(\text{s}) + 4\text{H}^+(\text{aq}) + \text{SO}_4^{2-}(\text{aq}) + 2\text{e}^- \rightarrow \text{PbSO}_4(\text{s}) + 2\text{H}_2\text{O}(\text{l})$
- C. $\text{PbSO}_4(\text{s}) + 2\text{e}^- \rightarrow \text{Pb}(\text{s}) + \text{SO}_4^{2-}(\text{aq})$
- D. $\text{PbSO}_4(\text{s}) + 2\text{H}_2\text{O}(\text{l}) \rightarrow \text{PbO}_2(\text{s}) + 4\text{H}^+(\text{aq}) + \text{SO}_4^{2-}(\text{aq}) + 2\text{e}^-$

Use the experimental arrangement below to answer Question 9.

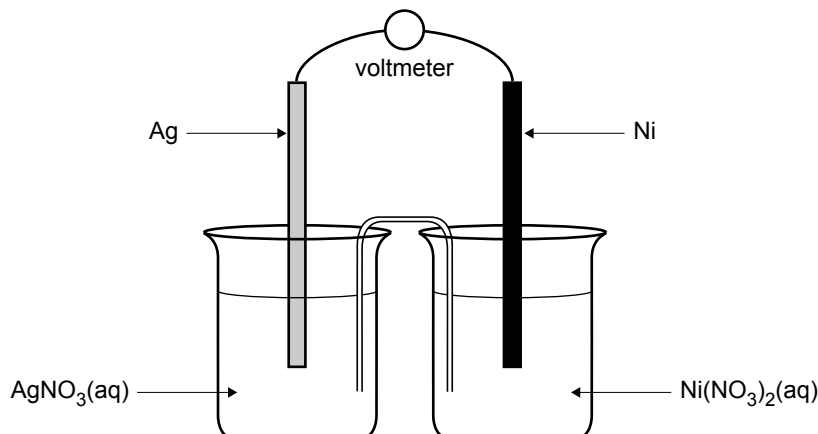

The experimental arrangement shows a

- silver rod dipping into a 1.0 M solution of $\text{AgNO}_3(\text{aq})$
- nickel rod dipping into a 1.0 M solution of $\text{Ni}(\text{NO}_3)_2(\text{aq})$

The solutions are connected to each other with a salt bridge consisting of an inverted U-tube containing ammonium nitrate solution.

Question 9

Which of the following alternatives correctly describes the polarity of, and the reaction that occurs at, the anode of this cell?

- | | anode polarity | reaction at the anode |
|----|-----------------------|---|
| A. | negative | $\text{Ag}^+(\text{aq}) + \text{e}^- \rightarrow \text{Ag}(\text{s})$ |
| B. | negative | $\text{Ni}(\text{s}) \rightarrow \text{Ni}^{2+}(\text{aq}) + 2\text{e}^-$ |
| C. | positive | $\text{Ag}^+(\text{aq}) + \text{e}^- \rightarrow \text{Ag}(\text{s})$ |
| D. | positive | $\text{Ni}(\text{s}) \rightarrow \text{Ni}^{2+}(\text{aq}) + 2\text{e}^-$ |

Question 10

In the periodic table, which electronic subshells are progressively filled in the second transition series, the actinides and the lanthanides?

	2nd transition series	actinides	lanthanides
A.	3d	4f	5f
B.	4d	5f	4f
C.	4d	6d	5d
D.	5d	5f	4f

Question 11

The origin of the Sun's energy is the conversion of hydrogen to helium.

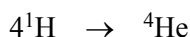

The relative isotopic mass of ^4He is 4.00260. However, the sum of the relative isotopic masses of the four ^1H is 4.03130.

This mass difference is

- A. a measure of the energy absorbed when four ^1H are converted to one ^4He .
- B. due to the loss of two electrons when four ^1H are converted to one ^4He .
- C. a measure of the energy released when four ^1H are converted to one ^4He .
- D. equal to the mass of the two positrons produced when four ^1H are converted to one ^4He .

Question 12

Consider the oxides from the third period, Na_2O , MgO , Al_2O_3 , P_4O_{10} and SO_3 .

Identify correctly their properties.

	Na_2O	MgO	Al_2O_3	P_4O_{10}	SO_3
A.	acidic oxide	acidic oxide	amphoteric oxide	basic oxide	basic oxide
B.	basic oxide	basic oxide	basic oxide	acidic oxide	acidic oxide
C.	basic oxide	basic oxide	amphoteric oxide	acidic oxide	acidic oxide
D.	basic oxide	basic oxide	amphoteric oxide	amphoteric oxide	amphoteric oxide

Question 13

The transition metal scandium forms the ion Sc^{3+} in water.

The electronic configuration of Sc^{3+} is

- A. $1s^2 2s^2 2p^6 3s^2 3p^6 3d^4 4s^2$
- B. $1s^2 2s^2 2p^6 3s^2 3p^6 3d^1 4s^2$
- C. $1s^2 2s^2 2p^6 3s^2 3p^4 4s^2$
- D. $1s^2 2s^2 2p^6 3s^2 3p^6$

Question 14

An element X has the following properties

- it is a good reductant
- it reacts readily with water to produce molecular hydrogen and a solution containing a colourless ion, X^{2+}
- it is naturally strongly radioactive.

Which of the following is most likely to be element X?

- A. Ra
- B. Cs
- C. Ca
- D. Po

Question 15

Mendeleev published his version of the periodic table in 1869.

Which one of the following statements about Mendeleev's periodic table is **not** correct?

- A. There were many gaps in the table.
- B. Each element had an atomic weight greater than the one before it.
- C. The table was used to predict the existence of some then unknown elements.
- D. The elements were arranged into vertical groups of elements with similar chemical properties.

Question 16

In which of the following sets are **all** the compounds likely to be coloured?

- A. KClO_4 , FeCl_2 , NH_4VO_3
- B. $\text{Ca}_3(\text{PO}_4)_2$, NH_4VO_3 , MgBr_2
- C. FeCl_2 , NiCl_2 , K_2CrO_4
- D. KClO_4 , MgBr_2 , $\text{Ca}_3(\text{PO}_4)_2$

Questions 17 and 18 refer to the following information.

Glycine, alanine and serine are three of the amino acids found in human proteins. Amino acids can react together to form polypeptides of varying length and composition. A **tripeptide** contains residues from three amino acids.

Question 17

If three glycine molecules (relative molecular mass 75) react together to form a tripeptide, the relative molecular mass of the product would be

- A. 171
- B. 189
- C. 207
- D. 225

Question 18

The number of different tripeptides that can be formed containing all three amino acids, glycine, alanine and serine, is

- A. 2
- B. 3
- C. 4
- D. 6

Question 19

Glycine is one of the amino acids that forms proteins. Protein that is not required in the body is broken down in the liver. Unwanted nitrogen is converted to urea and eliminated in the urine.

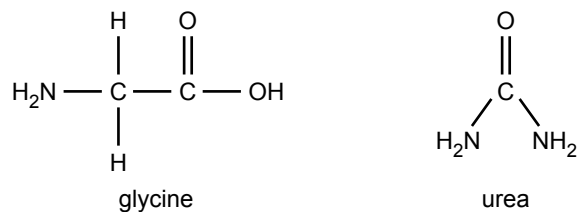

The maximum mass of urea (relative molecular mass = 60) that could be eliminated as a result of the breakdown of 1.00 g of glycine (relative molecular mass = 75) is, in gram,

- A. 0.40
- B. 0.80
- C. 1.00
- D. 1.60

Question 20

The carbon and nitrogen cycles both play an important role in food production.

Which of the following processes is part of **both** the nitrogen and carbon cycles?

- A. animal respiration
- B. denitrification in soil
- C. plant photosynthesis
- D. breakdown of urea fertiliser in soil

SECTION B – Short-answer questions**Instructions for Section B**

Answer **all** questions in the spaces provided.

Section B is worth approximately 73 per cent of the marks available.

To obtain full marks for your responses you should

- give simplified answers with an appropriate number of significant figures to all numerical questions; unsimplified answers will not be given full marks.
- show all working in your answers to numerical questions. No credit will be given for an incorrect answer unless it is accompanied by details of the working.
- make sure chemical equations are balanced and that the formulas for individual substances include an indication of state; for example, $\text{H}_2(\text{g})$; $\text{NaCl}(\text{s})$

Question 1

Stearic acid, $\text{CH}_3(\text{CH}_2)_{16}\text{COOH}$, is a common saturated fatty acid.

- a. What is meant by the term ‘saturated’?

1 mark

- b. Stearic acid can be used as a source of energy. Write a chemical equation for the complete reaction between oxygen and stearic acid.

2 marks

- c. The fats and oils in food are usually made up of a complex mixture of saturated and unsaturated fatty acids. During processing, additives are often added to prevent spoiling.

- i. What class of food additive is used specifically to prevent oils becoming rancid?

- ii. How does the additive prevent oils becoming rancid?

2 marks

Total 5 marks

Question 2

Lactic acid and alanine are both important chemicals in living systems.

Their structures are

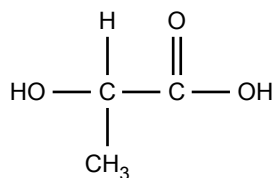

lactic acid

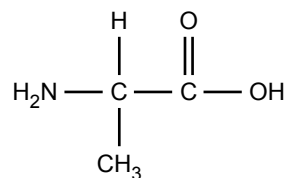

alanine

- a. Give the **name** of the functional group common to both compounds.

_____ 1 mark

- b. Why is alanine classified as an amino acid but lactic acid is not?

1 mark

- c. In the boxes below, draw structures of two different possible organic molecules formed by a condensation reaction between lactic acid and alanine.

2 marks

- d. For **one** of the structures given in part c.,
- circle the **new** functional group formed and
 - name the functional group that you have circled.

2 marks

Total 6 marks

SECTION B – continued

TURN OVER

Question 3

The energy content of food can be determined by completely burning a sample of the food in a bomb calorimeter and then calculating the energy released.

- a. The calorimeter must first be calibrated by passing an electric current through the calorimeter for a known period of time and measuring the resultant temperature rise. The data relevant to such a calibration is given below.

Current	1.78 A
Potential difference	5.65 V
Time	135 s
Temperature rise	1.15°C

Use the data above to calculate the calibration factor, in $\text{kJ } ^\circ\text{C}^{-1}$, for this calorimeter.

2 marks

- b. The carbohydrate, glucose, burns in excess oxygen according to the following equation.

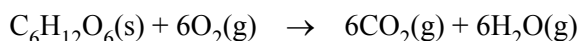

When a 1.324 g sample of glucose was burned in the calorimeter calibrated in part a. above, the temperature increased from 18.23°C to 35.55°C.

Calculate the molar heat of combustion of glucose in kJ mol^{-1} .

3 marks

- c. The carbohydrate, sucrose, is a disaccharide. Predict the approximate value of the ratio

$$\frac{\text{molar heat of combustion sucrose}}{\text{molar heat of combustion glucose}}$$

Approximate value of the above ratio is _____

Explain your reasoning.

2 marks

Total 7 marks

SECTION B – continued

Question 4

A piece of silver jewellery is coated with gold (Au) in an electrolytic cell that contains gold ions in an aqueous solution. Use the information below to determine the oxidation number of the gold ions in the aqueous solution.

volume of gold deposited	0.150 cm ³
density of gold	19.3 g cm ⁻³
cell current	4.00 A
time taken to plate jewellery	17.75 minutes

- a. Calculate the amount of electrons, in mole, passed through the cell.

2 marks

- b. Calculate the amount of gold, in mole, deposited on the jewellery.

2 marks

- c. i. Determine the ratio $\frac{n(e^-)}{n(\text{Au})}$.

- ii. Hence give the oxidation state of gold in the gold ions in this solution.

2 marks

Total 6 marks

Question 5

Give a concise answer to each of the following questions.

- a. The Downs Cell uses a molten electrolyte containing NaCl to produce sodium at an iron cathode. Explain why an aqueous solution of NaCl cannot be used to produce sodium at an iron cathode.

1 mark

- b. Alumina dissolved in molten cryolite is used in preference to molten alumina in the electrolytic production of aluminium. Explain why.

1 mark

- c. If the tertiary structure of an enzyme is disrupted, the enzyme is no longer active. Explain why.

2 marks

- d. When a solution of the enzyme amylase is boiled at 100°C for several minutes, the enzyme loses its tertiary structure yet its primary structure remains intact. Explain why.

3 marks

Total 7 marks

Question 6

- a. A natural gas-fired power station generates electricity by reacting gaseous methane (CH_4) with oxygen. List, in order, the energy conversions that take place in the power station during this process.

2 marks

- b. Less electricity is generated by burning methane in a gas power station than if the same amount of methane were used in a fuel cell.
- i. Give one reason for this difference.

- ii. State one factor that limits the widespread applications of fuel cells to generate electricity.

2 marks

Total 4 marks

Question 7

The element antimony (Sb) has at least 29 known isotopes. Only two of these are stable isotopes that occur naturally; the other 27 isotopes are radioactive and have been made artificially. The stable isotopes are $^{121}_{51}\text{Sb}$ (relative isotopic mass = 120.9038) and $^{123}_{51}\text{Sb}$ (relative isotopic mass = 122.9041). The relative atomic mass of naturally occurring antimony of 121.75 has been determined using mass spectrometry.

- a. The flow chart below represents the sequence of operations in a mass spectrometer. Three of the stages are labelled.

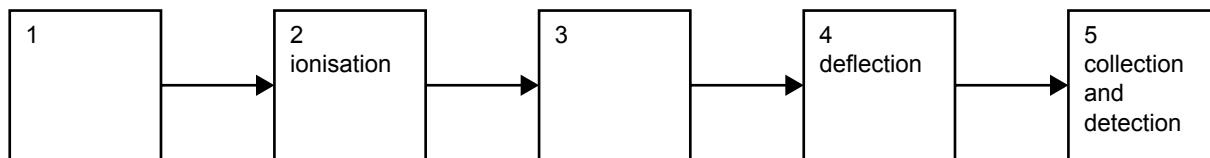

- i. What operations occur in stages 1 and 3?

stage 1 _____

stage 3 _____

- ii. How is ionisation achieved in stage 2?

- iii. How is deflection achieved in stage 4?

2 + 1 + 1 = 4 marks

- b. What information can be obtained from a mass spectrometer about naturally occurring antimony?

2 marks

- c. From the data given, calculate the percentage abundance of each of the stable isotopes of naturally occurring antimony.

3 marks

- d. Give the symbol and charge of the **most common antimony ion** that would be detected using mass spectrometry.

1 mark

- e. How many neutrons are there in the nucleus of the $^{121}_{51}\text{Sb}$ isotope?

1 mark

- f. Two of the radioactive isotopes of antimony are

- $^{125}_{51}\text{Sb}$ which decays by emission of a beta particle (an electron) and
- $^{117}_{51}\text{Sb}$ which decays by positron emission (a positive electron).

Give the symbol of the atoms produced from the decay process of each of the given radioactive isotopes.

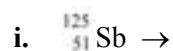

2 marks

Total 13 marks

Question 8

- a. Cobalt is one of the three metals in the first transition series that is ferromagnetic (magnetic). Give the name or symbol of one of the other two ferromagnetic metals in the first transition series.

1 mark

- b. Cobalt can form the complex ion $\text{Co}(\text{NH}_3)_6^{3+}$ in the presence of ammonia.

- i. Sketch the structure for $\text{Co}(\text{NH}_3)_6^{3+}$.

- ii. Name the type of bonding that exists

• between Co^{3+} ion and the NH_3 molecules _____

• within the NH_3 molecule _____

1 + 2 = 3 marks

- c. Suggest a reason why NH_3 might bond more firmly to Co^{3+} than to Co^{2+} .

1 mark

- d. Part of the electrochemical series is given below and should be used to answer the following questions.

	half reaction	E° value in volt
1	$\text{Co}(\text{H}_2\text{O})_6^{3+}(\text{aq}) + \text{e}^- \rightarrow \text{Co}(\text{H}_2\text{O})_6^{2+}(\text{aq})$	1.81
2	$\text{O}_{2(\text{g})} + 4\text{H}^+(\text{aq}) + 4\text{e}^- \rightarrow 2\text{H}_2\text{O}(\text{l})$	1.23
3	$\text{Co}(\text{NH}_3)_6^{3+}(\text{aq}) + \text{e}^- \rightarrow \text{Co}(\text{NH}_3)_6^{2+}(\text{aq})$	0.10
4	$2\text{H}^+(\text{aq}) + 2\text{e}^- \rightarrow \text{H}_2(\text{g})$	0.00
5	$\text{Co}(\text{H}_2\text{O})_6^{2+}(\text{aq}) + 2\text{e}^- \rightarrow \text{Co}(\text{s}) + 6\text{H}_2\text{O}(\text{l})$	-0.28
6	$\text{Co}(\text{NH}_3)_6^{2+}(\text{aq}) + 2\text{e}^- \rightarrow \text{Co}(\text{s}) + 6\text{NH}_3(\text{aq})$	-0.43
7	$2\text{H}_2\text{O}(\text{l}) + 2\text{e}^- \rightarrow \text{H}_2(\text{g}) + 2\text{OH}^-(\text{aq})$	-0.83

- i. Select two of the above half reactions which together indicate that, in aqueous solution, NH_3 bonds to Co^{3+} rather than to Co^{2+} .

- ii. Explain, using the above data, why aqueous solutions containing $\text{Co}(\text{H}_2\text{O})_6^{3+}(\text{aq})$ might be too unstable to be conveniently used in the laboratory.

2 marks

Total 7 marks