



CANDIDATE  
NAME

CENTRE  
NUMBER

--	--	--	--	--

CANDIDATE  
NUMBER

--	--	--	--



**PHYSICS**

**9792/02**

Paper 2 Part A Written Paper

**May/June 2012**

**2 hours**

Candidates answer on the Question Paper.

No Additional Materials are required.

**READ THESE INSTRUCTIONS FIRST**

Write your Centre number, candidate number and name on all the work you hand in.

Write in dark blue or black pen.

You may use a pencil for any diagrams, graphs or rough working.

Do not use staples, paper clips, highlighters, glue or correction fluid.

DO **NOT** WRITE IN ANY BARCODES.

**Section A**

Answer **all** questions.

You are advised to spend about 1 hour 30 minutes on this section.

**Section B**

Answer the **one** question.

You are advised to spend about 30 minutes on this section.

The question is based on the material in the Insert.

You may lose marks if you do not show your working or if you do not use appropriate units.

At the end of the examination, fasten all your work securely together.

The number of marks is given in brackets [ ] at the end of each question or part question.

For Examiner's Use	
1	
2	
3	
4	
5	
6	
7	
8	
<b>Total</b>	

This document consists of **20** printed pages, **4** blank pages and **1** insert.



**Data**

gravitational field strength close to Earth's surface	$g = 9.81 \text{ N kg}^{-1}$
elementary charge	$e = 1.60 \times 10^{-19} \text{ C}$
speed of light in vacuum	$c = 3.00 \times 10^8 \text{ m s}^{-1}$
Planck constant	$h = 6.63 \times 10^{-34} \text{ J s}$
permittivity of free space	$\epsilon_0 = 8.85 \times 10^{-12} \text{ F m}^{-1}$
gravitational constant	$G = 6.67 \times 10^{-11} \text{ N m}^2 \text{ kg}^{-2}$
electron mass	$m_e = 9.11 \times 10^{-31} \text{ kg}$
proton mass	$m_p = 1.67 \times 10^{-27} \text{ kg}$
unified atomic mass constant	$u = 1.66 \times 10^{-27} \text{ kg}$
molar gas constant	$R = 8.31 \text{ J K}^{-1} \text{ mol}^{-1}$
Avogadro constant	$N_A = 6.02 \times 10^{23} \text{ mol}^{-1}$
Boltzmann constant	$k = 1.38 \times 10^{-23} \text{ J K}^{-1}$
Stefan-Boltzmann constant	$\sigma = 5.67 \times 10^{-8} \text{ W m}^{-2} \text{ K}^{-4}$

## Formulae

uniformly accelerated motion	$s = ut + \frac{1}{2} at^2$ $v^2 = u^2 + 2as$ $s = \left( \frac{u+v}{2} \right) t$	magnetic force	$F = BIl \sin \theta$ $F = BQv \sin \theta$
heating	$\Delta E = mc\Delta\theta$	electromagnetic induction	$E = \frac{-d(N\Phi)}{dt}$
change of state	$\Delta E = mL$	Hall effect	$V = Bvd$
refraction	$n = \frac{\sin\theta_1}{\sin\theta_2}$ $n = \frac{v_1}{v_2}$	time dilation	$t' = \frac{t}{\sqrt{1 - \frac{v^2}{c^2}}}$
photon energy	$E = hf$	kinetic theory	$\frac{1}{2} m \langle c^2 \rangle = \frac{3}{2} kT$
de Broglie wavelength	$\lambda = \frac{h}{p}$	work done on/by a gas	$W = p\Delta V$
simple harmonic motion	$x = A \cos \omega t$ $v = -A\omega \sin \omega t$ $a = -A\omega^2 \cos \omega t$ $F = -m\omega^2 x$ $E = \frac{1}{2} mA^2\omega^2$	radioactive decay	$\frac{dN}{dt} = -\lambda N$ $N = N_0 e^{-\lambda t}$ $t_{\frac{1}{2}} = \frac{\ln 2}{\lambda}$
energy stored in a capacitor	$W = \frac{1}{2} QV$	attenuation losses	$I = I_0 e^{-\mu x}$
electric force	$F = \frac{Q_1 Q_2}{4\pi\epsilon_0 r^2}$	mass-energy equivalence	$\Delta E = c^2 \Delta m$
electrostatic potential energy	$W = \frac{Q_1 Q_2}{4\pi\epsilon_0 r}$	hydrogen energy levels	$E_n = \frac{-13.6 \text{ eV}}{n^2}$
gravitational force	$F = \frac{-Gm_1 m_2}{r^2}$	Heisenberg uncertainty principle	$\Delta p \Delta x \geq \frac{h}{2\pi}$ $\Delta E \Delta t \geq \frac{h}{2\pi}$
gravitational potential energy	$E = \frac{-Gm_1 m_2}{r}$	Wien's law	$\lambda_{\max} \propto \frac{1}{T}$
		Stefan's law	$L = 4\pi\sigma r^2 T^4$
		electromagnetic radiation from a moving source	$\frac{\Delta\lambda}{\lambda} \approx \frac{\Delta f}{f} \approx \frac{v}{c}$

Section A

You are advised to spend 1½ hours answering this section.

1 (a) (i) State the difference between a vector and a scalar quantity.

.....  
.....  
..... [1]

(ii) Give two examples of each.

scalar	vector	
1. ....	1. ....	
2. ....	2. ....	[2]

(b) (i) Fig. 1.1 represents three vectors A, B and C.

Draw a sketch diagram in the space to the right of Fig. 1.1, to represent a vector D as the sum of the three vectors A, B and C.

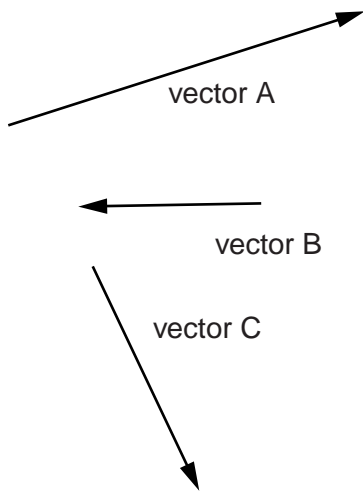

Fig. 1.1

[2]

- (ii) Fig. 1.2 represents a vector E of magnitude 37 units.

Calculate the magnitudes of the components of vector E in the x-direction and in the y-direction.

For  
Examiner's  
Use

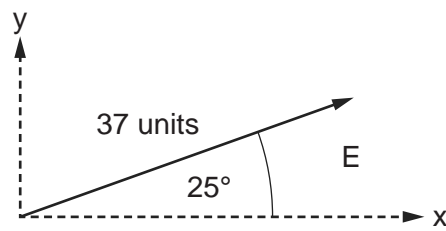

**Fig. 1.2** (not to scale)

component in x-direction = ..... units

component in y-direction = ..... units [2]

[Total: 7]

2 (a) Newton's third law of motion can be expressed in the following form.

When body A exerts a force on body B then body B exerts a force on body A. These forces are

- equal in magnitude,
- opposite in direction,
- of the same type.

Explain, using labelled force diagrams, how this applies to

(i) an object in free fall (no air resistance),

.....  
..... [2]

(ii) an object at rest on the floor.

.....  
..... [2]

(b) Air resistance increases as the speed of a falling object increases.

For  
Examiner's  
Use

(i) On Fig. 2.1, sketch a graph to show how the speed of an object falling from rest in air varies with time.

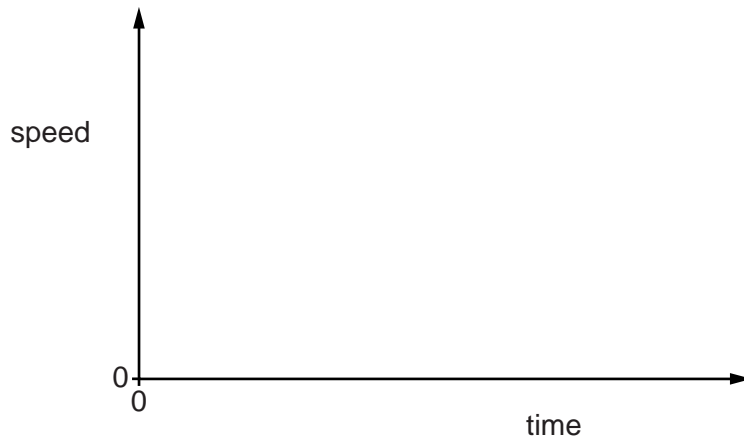

Fig. 2.1

[2]

(ii) Explain how Newton's third law applies as the air resistance on the falling object increases.

.....

.....

.....

.....

..... [2]

[Total: 8]

3 (a) From the definition of work done, show that power = force  $\times$  velocity.

.....  
.....  
.....  
.....[2]

(b) A car of mass 850 kg travelling at a constant speed of  $12.0 \text{ ms}^{-1}$  has a power output of 1800W.

Determine,

(i) the driving force,

driving force = ..... N [1]

(ii) the total resistive force on the car.

resistive force = ..... N [1]

(c) The car in (b) accelerates from  $12.0 \text{ ms}^{-1}$  with an initial acceleration of  $2.50 \text{ ms}^{-2}$ .

Calculate the new driving force.

driving force = ..... N [2]



- (d) After accelerating, the car in (c) reaches a constant speed of  $36.0 \text{ m s}^{-1}$ . The resistive force on the car is proportional to its speed squared.

For  
Examiner's  
Use

Calculate

- (i) the new resistive force on the car at  $36.0 \text{ m s}^{-1}$ ,

resistive force = ..... N [2]

- (ii) the new power output.

power output = ..... W [1]

- (e) When travelling at constant speed, the mathematical relationship between power output  $P$  and speed  $v$  is

$$P \propto v^n.$$

The power output at  $12.0 \text{ m s}^{-1}$  is  $1800 \text{ W}$ .

Using your answer to (d)(ii), show that  $n = 3$ .

[2]

[Total: 11]

- 4 Fig. 4.1 is a diagram of a domestic electrical circuit. The circuit allows many electrical components to be individually switched on or off. The supply voltage is 240V.

For  
Examiner's  
Use

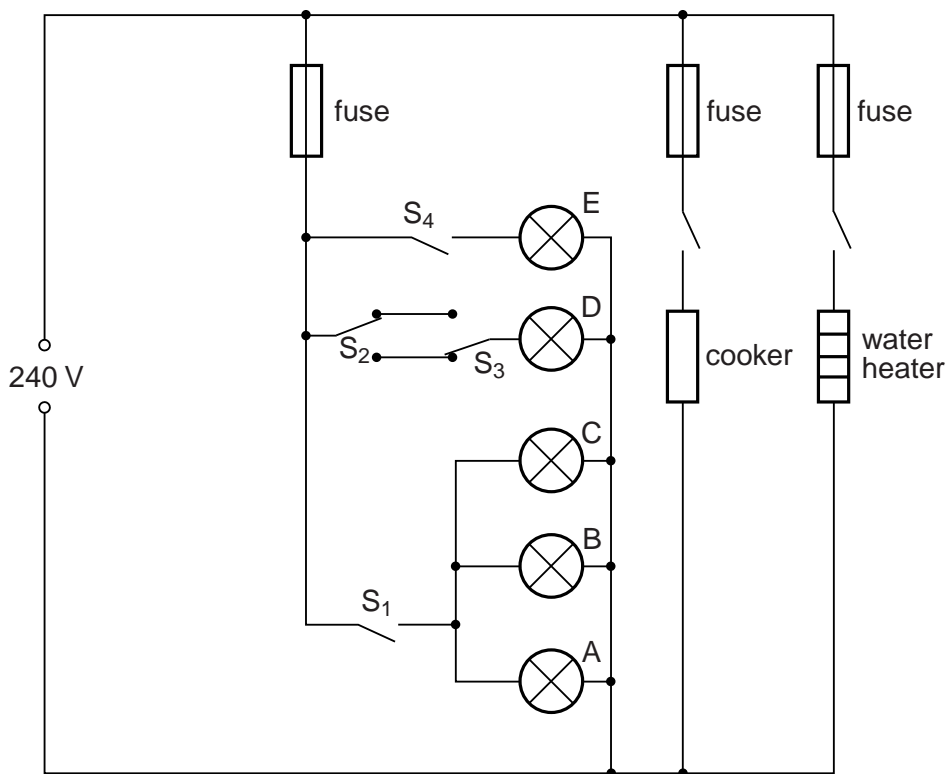

Fig. 4.1

- (a) (i) The water heater has a resistance of  $20\Omega$ . Calculate the power of the water heater.

power = ..... W [3]

- (ii) Calculate the time it will take the water heater to raise the temperature of 33kg of water from  $20^\circ\text{C}$  to  $60^\circ\text{C}$ , assuming no heat loss. The specific heat capacity of water is  $4200\text{Jkg}^{-1}\text{ }^\circ\text{C}^{-1}$ .

time = ..... s [2]

- (b) (i) State the effect of closing switch  $S_1$ .

..... [1]

(ii) Explain how switches  $S_2$  and  $S_3$  control lamp D.

.....  
 .....  
 ..... [2]

(iii) Calculate the resistance of lamp E, which is rated 10W.

resistance = .....  $\Omega$  [2]

(c) All the electrical sockets in a house are connected to a circuit called a ring main. The circuit is connected between P and Q to the 240V supply as shown in Fig. 4.2.

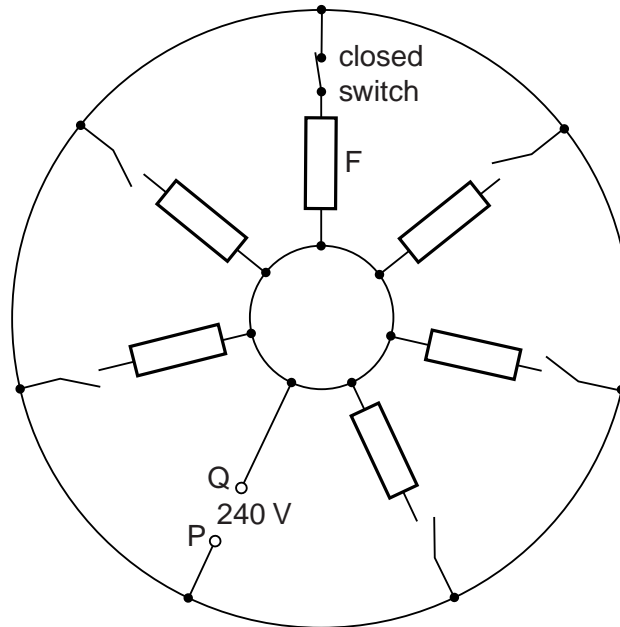

Fig. 4.2

(i) All the switches are open except the one to a computer at F, which is closed as shown. Draw arrows on Fig. 4.2 to show the paths of the current when the computer is in use at an instant in time when P is positive. [2]

(ii) Suggest two advantages of using a ring main.

1. ....  
 .....  
 2. ....  
 ..... [2]

[Total: 14]

5 (a) Describe the basic difference between the following terms. You may use diagrams to illustrate your answers.

(i) a *transverse* wave and a *longitudinal* wave

.....  
..... [2]

(ii) a *polarised* and a *non-polarised* wave

.....  
..... [2]

(iii) a *standing* wave and a *progressive* wave

.....  
..... [3]

- (b) (i) The light from a sodium lamp is analysed using an instrument containing a diffraction grating. The diffraction grating has 500 lines per millimetre. A spectral line in the second order spectrum is at an angle of  $36.09^\circ$ .

For  
Examiner's  
Use

Use the equation  $n\lambda = d\sin\theta$  to calculate the wavelength of the light causing this spectral line.

wavelength = ..... m [3]

- (ii) There is another second order spectral line at  $36.13^\circ$ .

Calculate the wavelength of the light causing this line.

wavelength = ..... m [1]

- (iii) The spectral lines are viewed using a lens of aperture  $b$ .

Use the Rayleigh criterion,  $\theta \approx \lambda/b$ , to find the approximate minimum size of the aperture that is able to resolve the two spectral lines.

minimum size = ..... m [3]

[Total: 14]

- 6 (a) In a fission process a neutron collides with a uranium-235 nucleus and causes a nuclear reaction summarised by the following equation.

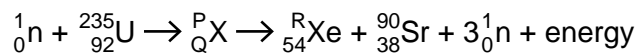

- (i) Give the numerical values of P, Q and R.

P = .....

Q = .....

R = .....

[2]

- (ii) State the feature of this equation that indicates that a chain reaction may be possible.

.....  
 .....  
 .....  
 ..... [1]

- (b) A strontium-90 nucleus emits a  $\beta^-$  particle and decays to yttrium (Y). The decay has a half-life of 28 years.

- (i) Write a nuclear transformation equation for the emission of the  $\beta^-$  particle.

[2]

- (ii) In a laboratory source of strontium-90, the number of atoms present in the year 2012 is  $2.36 \times 10^{13}$ .

Calculate the number of strontium atoms that will be present in the source in the year 2124 (112 years later).

number = ..... [3]

[Total: 8]

**BLANK PAGE**

**Section A continues on the next page.**





(c) The photoelectric effect was important in the development of a photon theory of electromagnetic radiation.

(i) State one observation of the photoelectric effect that cannot be explained using the wave model.

.....  
.....  
..... [1]

(ii) Explain how the wave model fails to account for this observation.

.....  
.....  
..... [1]

(iii) Explain how the photon model can account for this observation.

.....  
.....  
..... [1]

[Total: 13]

## Section B

For  
Examiner's  
Use

You are advised to spend about 30 minutes answering this section.  
Your answers should, where possible, make use of any relevant Physics.

- 8 The maglev train referred to in Extract 2 consists of 5 sections, each of mass  $4.80 \times 10^4$  kg. The train leaves a station and accelerates uniformly for 150 s. Fig. 8.1 is the velocity/time graph for the first 400 s of the journey.

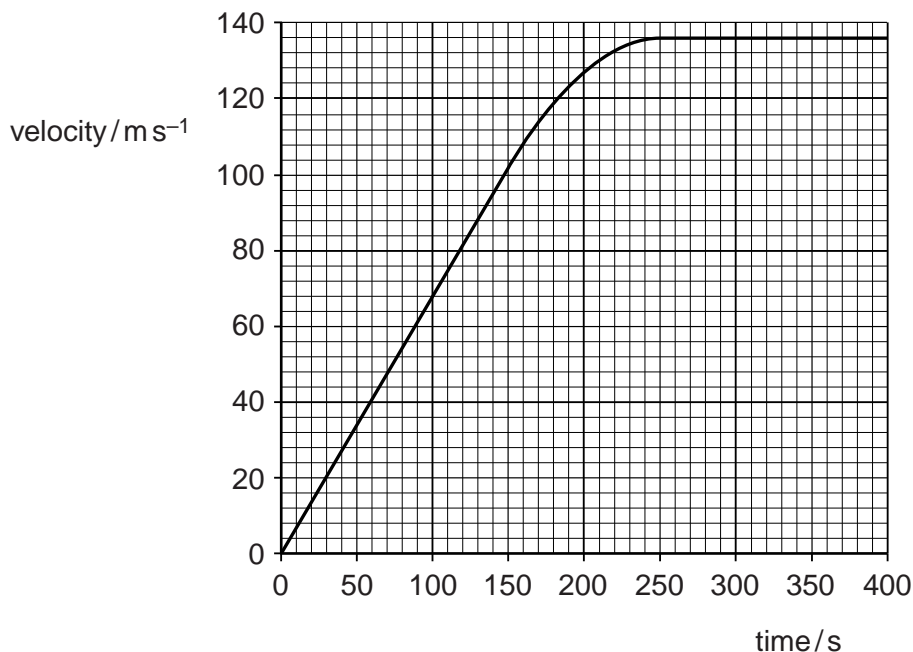

Fig. 8.1

- (a) (i) Use Fig. 8.1 to determine the acceleration of the train between  $t = 0$  and  $t = 150$  s.

acceleration = .....  $\text{m s}^{-2}$  [2]

- (ii) Calculate the resultant force acting on the train during the first 150 s of the journey.

force = ..... N [2]

- (iii) Hence state the rate at which the momentum of the train is changing during this time.

rate of change of momentum = .....  $\text{kg m s}^{-2}$  [1]

- (b) For the first 400s of its journey, the train is travelling along a straight, horizontal track. The train is powered by linear induction motors such as those referred to in Extract 4. During the first 150s of the journey, the force exerted on the train by the motors increases continuously.

Suggest why, despite the increasing force exerted by the motors, the acceleration of the train remains constant.

.....  
 .....  
 ..... [2]

- (c) The train reaches its maximum velocity at 250s. Use Fig. 8.1 to estimate the distance travelled by the train as it accelerates.

distance = ..... m [2]

- (d) At 400s, the train reaches a section of track that has an upward gradient of 2.00% (0.0200). A gradient of 2.00% means that the train gains 2.00m in height for every 100m it moves along the track. Along this upward section of the track, the train continues to travel at the same constant speed.

- (i) Use Fig. 8.1 to determine the speed of the train on this upward section of the track.

speed = ..... ms<sup>-1</sup> [1]

- (ii) Calculate the gain in gravitational potential energy of the train in 1.0 s.

energy gained in 1.0s = ..... J [3]

(iii) At 300 s, the power supplied to the train is  $9.80 \times 10^7 \text{W}$ .

Calculate the percentage increase in the power supplied to the train as it starts to travel uphill.

increase = .....% [2]

(e) The electromagnets used to levitate the train above the guideway have coils made from a material that is a superconductor.

(i) State what is meant by a *superconductor*.

.....  
.....[1]

(ii) State one advantage and one disadvantage of using a superconductor for this purpose.

advantage .....  
.....[1]

disadvantage .....  
.....[1]







## BLANK PAGE

---

*Copyright Acknowledgements:*

Extract 1	© Kevin Bonsor; <i>How Maglev Trains Work</i> ; <a href="http://science.howstuffworks.com/transport/engines-equipment/maglev-train.htm">http://science.howstuffworks.com/transport/engines-equipment/maglev-train.htm</a>
Extract 2	© <a href="http://www.monorails.org/tmspages/magshang.html">http://www.monorails.org/tmspages/magshang.html</a>
Extract 3	© <a href="http://www.o-keating.com/hsr/maglev.htm">http://www.o-keating.com/hsr/maglev.htm</a>
Extract 4	© <a href="http://www.explainthatstuff.com/linearmotor.html">http://www.explainthatstuff.com/linearmotor.html</a>
Extract 5	© <a href="http://www.newworldencyclopedia.org/entry/Maglev_train">http://www.newworldencyclopedia.org/entry/Maglev_train</a>
Extract 1 Photographs	© Railway Technical Research Institute
Extract 2 Photographs	© Transrapid International
Extract 4 Photograph	© NASA Marshall Space Flight Center

Permission to reproduce items where third-party owned material protected by copyright is included has been sought and cleared where possible. Every reasonable effort has been made by the publisher (UCLES) to trace copyright holders, but if any items requiring clearance have unwittingly been included, the publisher will be pleased to make amends at the earliest possible opportunity.

University of Cambridge International Examinations is part of the Cambridge Assessment Group. Cambridge Assessment is the brand name of University of Cambridge Local Examinations Syndicate (UCLES), which is itself a department of the University of Cambridge.