



UNIVERSITY OF CAMBRIDGE INTERNATIONAL EXAMINATIONS
General Certificate of Education Ordinary Level

PHYSICS

5054/32

Paper 3 Practical Test

October/November 2012

CONFIDENTIAL INSTRUCTIONS

Great care should be taken to ensure that any confidential information given does not reach the candidates either directly or indirectly.

No access to the Question Paper is permitted in advance of the examination.



If you have any problems or queries regarding these Instructions, please contact CIE
by e-mail: international@cie.org.uk,
by phone: +44 1223 553554,
by fax: +44 1223 553558,
stating the Centre number, the nature of the query and the syllabus number quoted above.

This document consists of **10** printed pages and **2** blank pages.



Instructions for preparing apparatus

These instructions detail the apparatus required for each experiment in this paper. No access is permitted to the Question Paper in advance of the examination session.

Number of sets of apparatus

In addition to a few spare sets, the minimum number of sets of apparatus to be provided should be sufficient to enable candidates to spend 20 minutes with the apparatus for each of Questions 1, 2 and 3, and one hour with the apparatus for Question 4. The order in which candidates answer the questions will be determined by the Supervisor. Candidates may spend one hour circulating around Questions 1, 2 and 3, followed by an hour on Question 4, or vice versa.

It is assumed that candidates will supply their own calculator and geometrical instruments, such as a set square, 0° to 180° protractor, pair of compasses and 30 cm rule. Candidates should be advised in advance that they may, if they wish, use quartz wristwatches with stopwatch facilities, providing that such wristwatches afford the required precision.

Instructions for the supervision of the examination

The Supervisor, who may be a Physics teacher, is responsible for the administration of the examination according to the procedures detailed in the Handbook for Centres. In all instances, a Physics teacher should be present. Preferably, this teacher should have been responsible for the preparation of the apparatus. Two invigilators must be present at all times: it is not acceptable for a teacher who has been responsible for preparing the candidates for this paper to be the sole Supervisor or Invigilator.

Supervisors may make the following announcement at the start of the examination.

'The Examiners do not want you to waste time when you are unable to do any experiment. Any candidate who is unable to get results with an experiment may ask for help. The extent of this help will be reported to the Examiners, who may make a deduction of marks.'

Supervisors should note that a candidate may only be given enough assistance to allow some raw readings or observations to be made. On no account should any assistance be given with the treatment or analysis of these readings and observations.

Supervisors may draw to the attention of the candidates any significant deviation between the apparatus provided and that detailed in the Question Paper, particularly where diagrams are given in the paper.

Candidates should be reminded that all their work should be written on the Question Paper. Rough paper must not be used.

The Supervisor must complete the Report at the back of these Instructions. Details should be given of any significant deviation between the apparatus used and that specified in these Instructions. A sample set of results can often help Examiners. A copy of this Report must be included in **each** packet of scripts.

Question 1**Items to be supplied by the Centre (per set of apparatus, unless otherwise specified)**

Block of wood of mass approximately 200 g (see Note 1).

30 cm length of board that can be used to form a ramp (see Note 2).

Rod (see Note 3).

Stand and boss to support the rod.

Piece of Blu-Tack (see Note 4 and Note 5).

200 g mass (see Note 5).

Metre rule with a millimetre scale.

Set square.

Notes

1. The block must be cuboid in shape. Possible dimensions are 7 cm × 5 cm × 10 cm for wood of average density. However, Centres may use any blocks that are available, provided the mass is approximately 200 g. One of the largest faces of the block should be labelled A. This should be done with a permanent marker pen directly onto the block. A sticky label must not be used.
2. The board should be 30 cm long and at least 5 cm wider than the block of wood selected. It should be stiff so that it does not bend when inclined, with the block of wood placed on it.
3. The length of the rod should be the same as, or longer than, the width of the board. The rod could be a piece of wooden dowel or the rod end of a clamp.

When the ramp is in the inclined position, the rod supports the ramp as shown in Fig. 1.1. The Supervisor should clamp the rod to the stand with the boss. The **candidate** will set up the ramp.

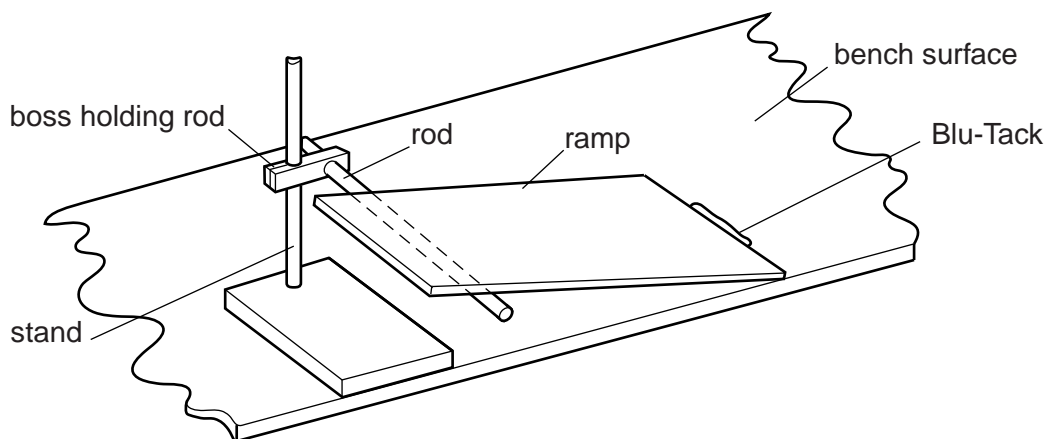

Fig. 1.1

4. The candidate will use some of the Blu-Tack at the end of the ramp to prevent it sliding on the bench.
5. If two 100 g slotted masses are used to form the 200 g mass, they should be taped together. The candidate will secure the 200 g mass to the wooden block with Blu-Tack during the experiment.
6. At the changeover, the Supervisor should return the apparatus to its initial state, ensuring that the 200 g mass has been removed from the block.

Information required by Examiners

Sample set of numerical results, clearly marked "Supervisor's Results", obtained out of sight of the candidates.

Question 2**Items to be supplied by the Centre (per set of apparatus, unless otherwise specified)**

3.0V d.c. power supply, e.g. two 1.5V dry cells in a suitable holder.

Switch or plug key.

Red light-emitting diode (LED) (see Note 1).

Voltmeter capable of measuring a voltage of up to 2V to a precision of 0.05V. A digital or analogue meter is suitable (see Note 2).

Resistor of nominal value $100\ \Omega$ (see Note 3).

Resistor of nominal value $330\ \Omega$ (see Note 3).

Four connecting leads to enable the Supervisor to set up the circuit shown in Fig. 2.1 (see Note 4).

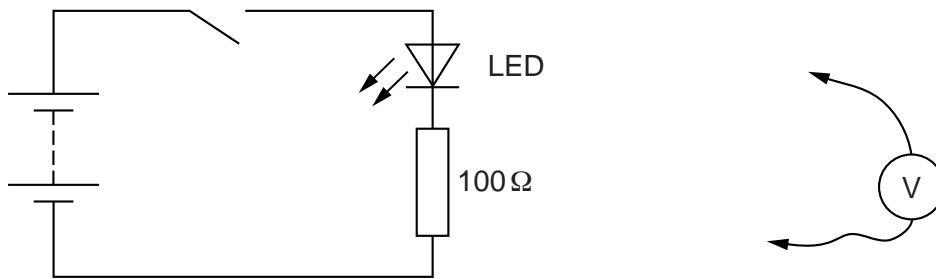

Fig. 2.1

Notes

1. The red LED should have an operating current of about 10 mA and an operating voltage of about 2V. It should have a diameter of 5 mm and be of the diffused light type, e.g. RS Components 826-363.
2. The voltmeter should have two connecting leads so that it can be connected across components in the circuit.
3. The resistors and the LED should all have suitable terminals so that
 - the $100\ \Omega$ resistor can be removed and replaced with the $330\ \Omega$ resistor,
 - the candidate can connect the voltmeter in parallel with the individual components in turn.

The nominal values of the two resistors should be clearly marked on the resistors.

This can be done by placing masking tape around the resistor and then writing its resistance on the masking tape.

4. The Supervisor should set up the circuit as shown in Fig. 2.1.
5. At the changeover, the Supervisor should remove the $330\ \Omega$ resistor from the circuit and replace it with the $100\ \Omega$ resistor. The circuit should still be set up as shown in Fig. 2.1 with the voltmeter disconnected. The switch should be open.

Information required by Examiners

Sample set of numerical results, clearly marked “Supervisor’s Results”, obtained out of sight of the candidates.

Question 3**Items to be supplied by the Centre (per set of apparatus, unless otherwise specified)**

Expendable steel spring, with a spring constant of approximately 25 N/m, e.g. Griffin catalogue number XBV-590-010H.

100 g mass hanger with one 100 g slotted mass, giving a total mass of 200 g.

Stand, boss and clamp to support the spring.

Metre rule with a millimetre scale.

Second boss and clamp to support the metre rule from the stand.

Set square.

S-hook.

Approximately 120 g of modelling clay, e.g. Plasticine (see Note 1).

Notes

1. The modelling clay should be formed around the lower half of the S-hook. The total mass of the S-hook and the modelling clay should be $120\text{ g} \pm 2\text{ g}$. It should be possible for the **candidate** to suspend the hook from the spring.
2. At the changeover, the Supervisor should dismantle the apparatus set up by the candidate and ensure that the total mass of the modelling clay and the hook is still $120\text{ g} \pm 2\text{ g}$.

Information required by Examiners

Sample set of numerical results, clearly marked "Supervisor's Results", obtained out of sight of the candidates.

Question 4**Items to be supplied by the Centre (per set of apparatus, unless otherwise specified)**

Tennis ball.

Piece of wood of minimum length 1.1 m and minimum width 10 cm (see Note 1).

Blu-Tack.

Masking tape.

Wooden block of height approximately 10 cm (see Note 2).

Two metre rules with millimetre scales (see Note 3).

Stopwatch reading to 0.1 s or better (a digital stopwatch is suitable).

A stop (see Note 4).

Set square.

Half-metre rule with a millimetre scale.

Notes

1. This will be used to form a ramp down which the tennis ball will roll.
2. The block should be placed under one end of the piece of wood to form a ramp. The Supervisor should check that the tennis ball takes approximately 2 seconds to roll 90.0 cm down the ramp from rest. If necessary the height of the block of wood or its position under the ramp should be changed so that this time is achieved. The ramp should then be secured to the block and to the bench with Blu-Tack. The position of the block and the lower end of the ramp should be marked on the bench with masking tape so that the apparatus can be restored to its initial position if it is disturbed.
3. The metre rules should be placed along the ramp. They should be parallel to the edge of the ramp with a gap between them. The gap is to form a channel down which the tennis ball will roll. The 0.0 cm ends of the rules should both be at the edge of the bottom of the ramp. Blu-Tack should be used beneath the rules to secure them in this position. The rule nearest the candidate should be secured at the edge of the ramp as shown in Fig. 4.1.

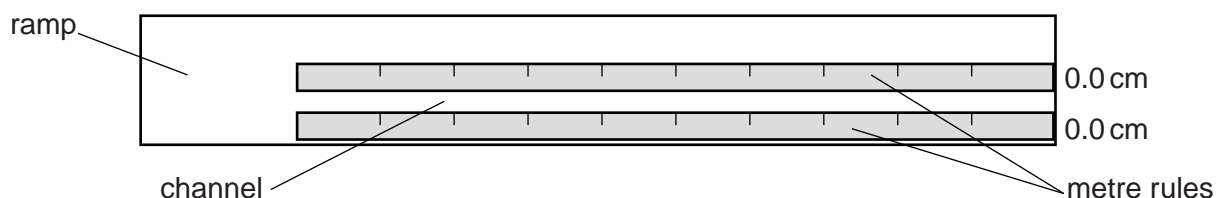

Fig. 4.1 (top view)

4. The stop should be placed on the bench up against the bottom of the ramp. A solid object such as a brick or block of wood is suitable.

5. The Supervisor should set up the apparatus as shown in Fig. 4.2.

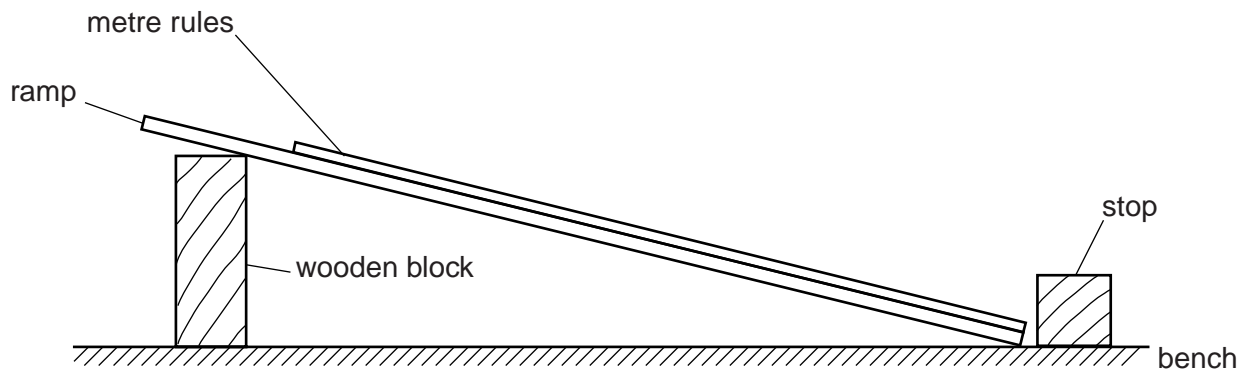

Fig. 4.2 (side view)

6. At the changeover, the Supervisor should check that the apparatus is still set up as described above.

Information required by Examiners

Sample set of numerical results, clearly marked "Supervisor's Results", obtained out of sight of the candidates.

Permission to reproduce items where third-party owned material protected by copyright is included has been sought and cleared where possible. Every reasonable effort has been made by the publisher (UCLES) to trace copyright holders, but if any items requiring clearance have unwittingly been included, the publisher will be pleased to make amends at the earliest possible opportunity.

University of Cambridge International Examinations is part of the Cambridge Assessment Group. Cambridge Assessment is the brand name of University of Cambridge Local Examinations Syndicate (UCLES), which is itself a department of the University of Cambridge.

This form must be completed and returned with the candidates' scripts.

REPORT ON PRACTICAL PHYSICS

The Supervisor is asked to give the following details, using the space provided on page 12.

- (a) Information required at the end of the test, as indicated in the Instructions.
- (b) Any help given to a candidate.
- (c) Any general difficulties encountered in preparing the apparatus.
- (d) Any difficulties experienced by particular candidates. These should include reference to difficulties due to faulty apparatus or materials and accidental damage to apparatus or materials. Candidates should be identified by name and candidate number.

Other cases of hardship, such as disability or illness, should be reported to CIE in the normal way.

The Supervisor is asked to provide a plan of the work benches, giving details by candidate numbers of the places occupied by the candidates for each session. The plan and report should be enclosed in the envelope containing the candidates' scripts. If more than one envelope is used, a copy of the report must be enclosed in each envelope.

Declaration to be signed by the Principal

The preparation of this practical examination has been carried out so as to maintain fully the security of the examination.

Signed

Name (in block capitals)

Centre number

Centre name



Information required

For each question, please enclose a sample set of numerical results, obtained out of sight of the candidates and clearly labelled "Supervisor's Results".

Details of difficulties and any help given to candidates

