



UNIVERSITY OF CAMBRIDGE INTERNATIONAL EXAMINATIONS  
General Certificate of Education Ordinary Level

CANDIDATE  
NAME

CENTRE  
NUMBER

--	--	--	--	--

CANDIDATE  
NUMBER

--	--	--	--



**PHYSICS**

**5054/31**

Paper 3 Practical Test

**October/November 2011**

**2 hours**

Candidates answer on the Question Paper.

Additional Materials: As listed in the Confidential Instructions.

**READ THESE INSTRUCTIONS FIRST**

Write your Centre number, candidate number and name on all the work you hand in.

Write in dark blue or black pen.

You may use a pencil for any diagrams, graphs or rough working.

Do not use staples, paper clips, highlighters, glue or correction fluid.

**DO NOT WRITE IN ANY BARCODES.**

Answer **all** questions.

For each of the questions in Section A, you will be allowed to work with the apparatus for a maximum of 20 minutes. For the question in Section B, you will be allowed to work with the apparatus for a maximum of 1 hour.

You are expected to record all your observations as soon as these observations are made.

You may lose marks if you do not show your working or if you do not use appropriate units.

An account of the method of carrying out the experiments is **not** required.

At the end of the examination, fasten all your work securely together.

The number of marks is given in brackets [ ] at the end of each question or part question.

For Examiner's Use	
1	
2	
3	
4	
<b>Total</b>	

This document consists of **10** printed pages and **2** blank pages.



## Section A

Answer **all** questions in this section.

For  
Examiner's  
Use

1 In this experiment, you will investigate the equilibrium of a suspended mass.

You have been provided with

- a mass, labelled M, suspended from a stand and clamp by a length of string,
- a second length of string attached to the first length of string at one end and with a loop at the other end,
- a pulley supported above the bench,
- a 50 g mass with a hook,
- a metre rule,
- a set square.

(a) Set up the apparatus as shown in Fig. 1.1.

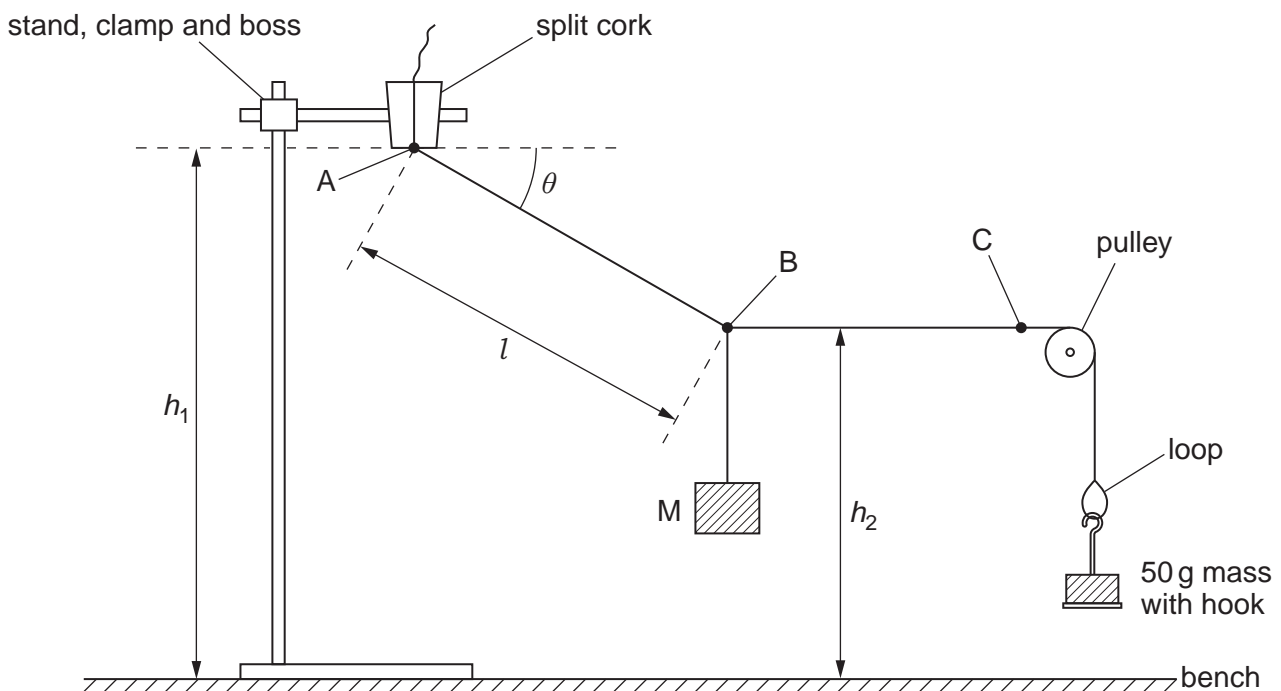

Fig. 1.1

Pass the second length of string over the pulley and suspend the 50 g mass from the loop. Adjust the position and height of the pulley so that string BC is horizontal.

- (b) Explain how you made sure that BC was horizontal. You may add to Fig. 1.1 if you wish.

.....

.....

.....

[1]

- (c) Measure and record the vertical heights  $h_1$  and  $h_2$  shown in Fig. 1.1. Also measure and record the length  $l$  of the string between the two points A and B.

$h_1 =$  .....

$h_2 =$  .....

$l =$  .....

[2]

- (d) Calculate the angle  $\theta$  between the string AB and the horizontal, using the relationship

$$\sin \theta = \frac{h_1 - h_2}{l}.$$

$\theta =$  ..... [2]

[Total: 5]

For  
Examiner's  
Use

2 In this experiment, you will investigate the motion of a mass suspended from a spring.

You have been provided with

- a spring,
- a 100 g mass hanger and four 100 g slotted masses,
- a stopwatch,
- a pin in a cork,
- a stand with two clamps and two bosses.

(a) (i) Set up the apparatus as shown in Fig. 2.1, with a total mass of 300 g suspended from the spring.

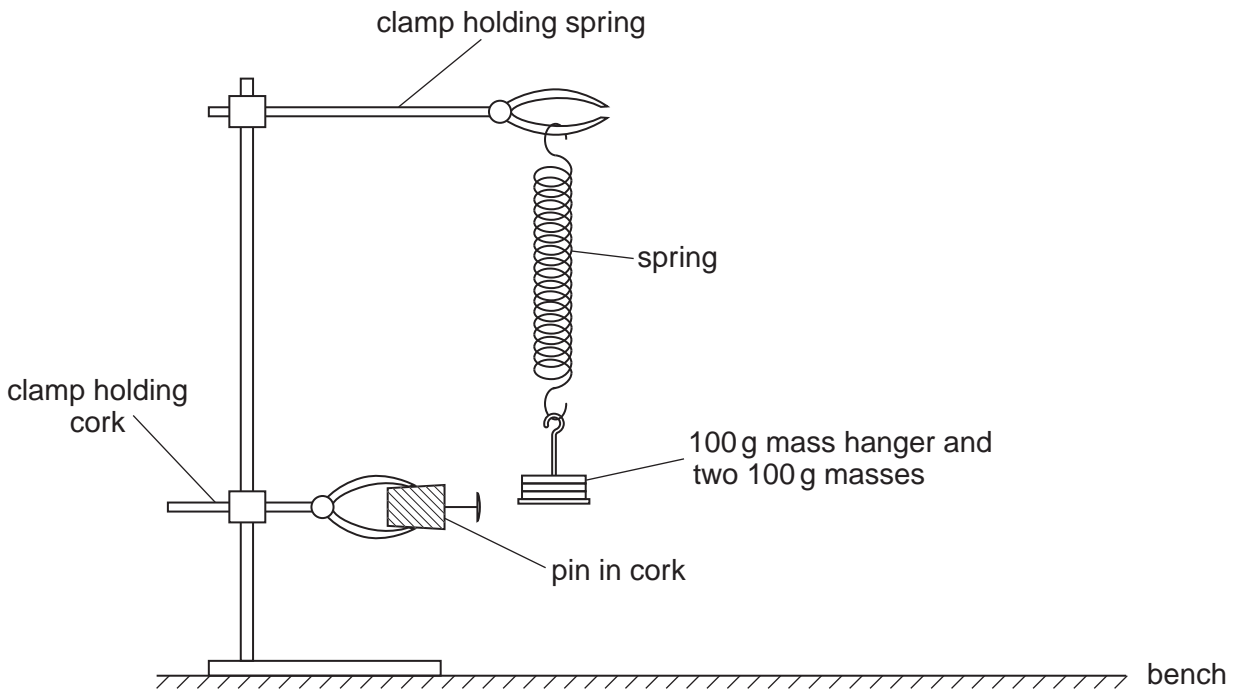

Fig. 2.1

Adjust the lower clamp so that the pin marks the position of the bottom of the mass hanger when the mass is stationary. When the mass is pulled downwards a small distance and released, it vibrates up and down. One complete vibration is from the position of the pin, up to the highest position, down to the lowest position and back up to the position of the pin, as shown in Fig. 2.2.

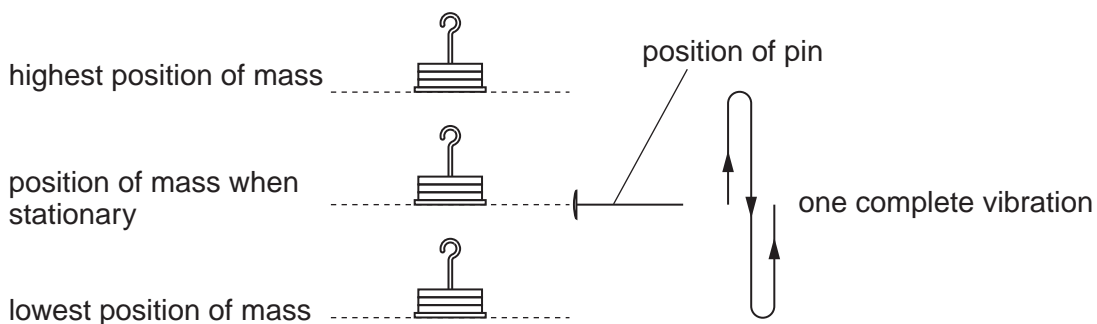

Fig. 2.2

- (ii) The time for 20 complete vibrations is  $t_1$ . Take measurements to determine an accurate value of  $t_1$ .

For  
Examiner's  
Use

$$t_1 = \dots\dots\dots [1]$$

- (iii) Calculate the time  $T_1$  for one vibration.

$$T_1 = \dots\dots\dots [1]$$

- (b) Add 200g to the mass hanger so that the total mass suspended from the spring is 500g.

- (i) Determine an accurate value for the time  $t_2$  taken for 20 complete vibrations.

$$t_2 = \dots\dots\dots$$

- (ii) Calculate the time  $T_2$  for one vibration.

$$T_2 = \dots\dots\dots [1]$$

- (c) Calculate the value of  $\frac{T_2}{T_1}$ .

$$\frac{T_2}{T_1} = \dots\dots\dots [2]$$

[Total: 5]

- 3 In this experiment, you will determine an accurate value for the spacing of the holes in a board.

You have been provided with

- a board with regularly spaced holes,
- a light source to illuminate the board,
- a lens in a holder,
- a screen,
- a metre rule,
- a set square.

- (a) Set up the apparatus as shown in Fig. 3.1.

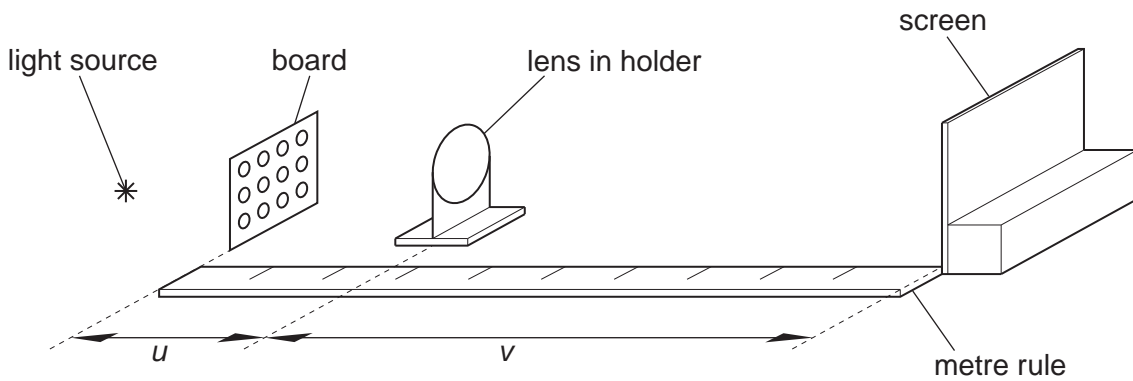

Fig. 3.1

The board and the screen must be 100.0 cm apart.

- (b) Adjust the position of the lens until a sharply-focused, **magnified** image of the board is formed on the screen.

Measure and record

- (i) the distance  $u$  between the board and the lens,

$u = \dots\dots\dots$

- (ii) the distance  $v$  between the lens and the screen.

$v = \dots\dots\dots$

[2]

- (c) The image on the screen is a set of regularly-spaced bright spots. The distance between two adjacent bright spots is  $d$ .

For  
Examiner's  
Use

- (i) Take measurements to determine an accurate value of  $d$ .

$$d = \dots\dots\dots [1]$$

- (ii) Explain, with the aid of a diagram, the technique that you used to determine an accurate value of  $d$ .

.....  
 .....  
 ..... [1]

- (d) The spacing  $s$  between the holes on the board is given by the relationship

$$s = \frac{d u}{v}$$

Using your answers in (b) and (c)(i), calculate the value of  $s$ .

$$s = \dots\dots\dots [1]$$

[Total: 5]





## Section B

- 4 *In this experiment, you will investigate the relationship between the potential difference across part of a circuit and the current in the circuit.*

You have been provided with an incomplete circuit consisting of

- a power supply,
- a resistor labelled X,
- a voltmeter,
- an ammeter,
- a switch,
- two terminals labelled A and B.

You have also been provided with additional connecting leads and three further resistors labelled with the values of their resistance.

The resistors may become hot during the course of the experiment.

- (a) (i) Connect the  $15\ \Omega$  resistor between terminals A and B.
- (ii) Draw a circuit diagram of the completed circuit.

[2]

- (b) Close the switch and record the reading  $V$  on the voltmeter and the current  $I$  in the circuit. Open the switch.

$V =$  .....

$I =$  .....

[2]

- (c) Replace the  $15\Omega$  resistor with
- the  $10\Omega$  resistor,
  - the  $22\Omega$  resistor,
  - all **series** combinations of  $10\Omega$ ,  $15\Omega$  and  $22\Omega$  resistors.

In each case, repeat (b) and record your results in a table. Include a column showing the resistors that you connect between A and B. Also include your results from (b).

[4]

- (d) Using the grid opposite, plot a graph of  $V/V$  against  $I/A$ . Draw a straight line of best fit through your points. [4]

- (e) Determine the gradient of the line of best fit.

gradient = .....[3]

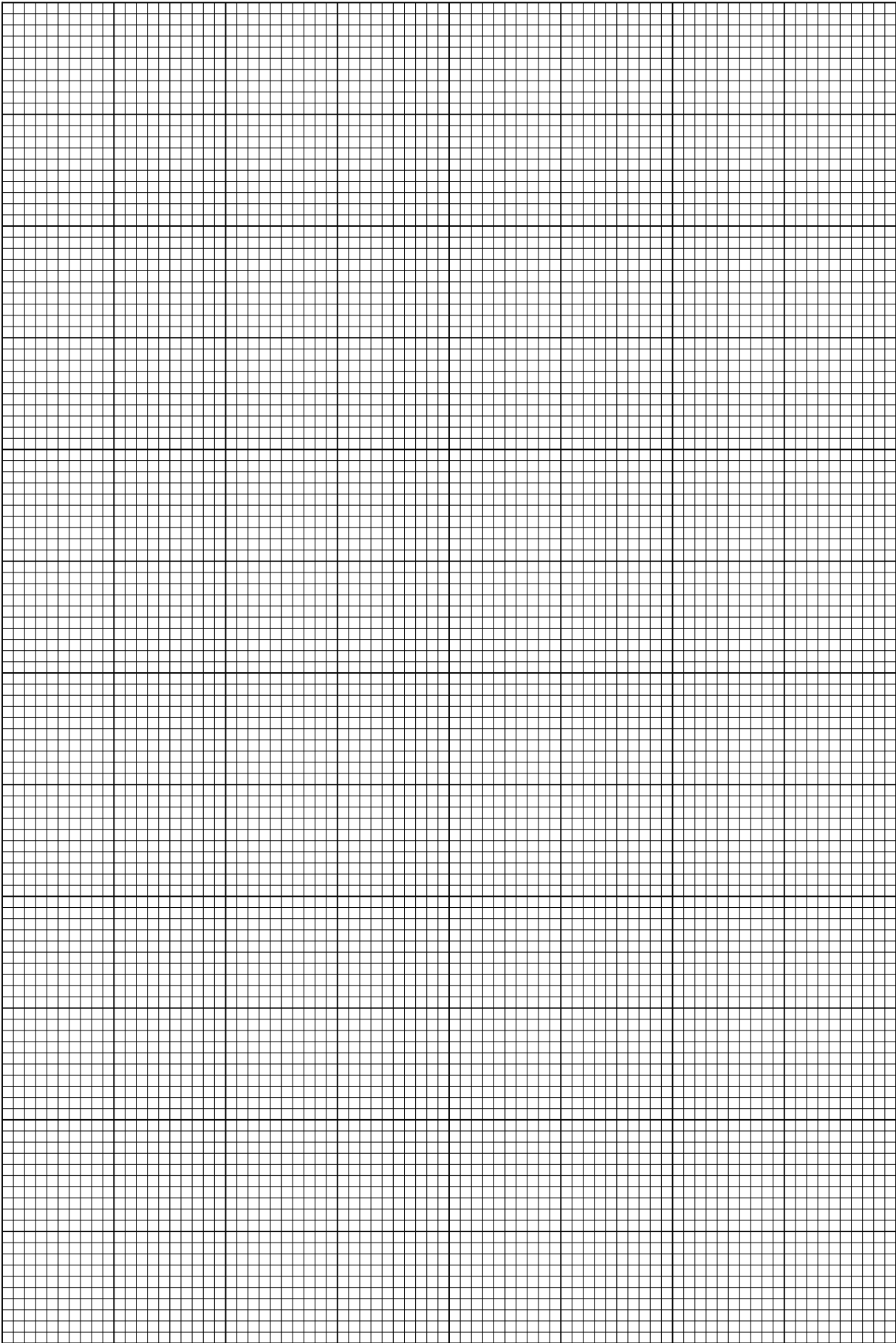

[Total: 15]

**BLANK PAGE**

---

Permission to reproduce items where third-party owned material protected by copyright is included has been sought and cleared where possible. Every reasonable effort has been made by the publisher (UCLES) to trace copyright holders, but if any items requiring clearance have unwittingly been included, the publisher will be pleased to make amends at the earliest possible opportunity.

University of Cambridge International Examinations is part of the Cambridge Assessment Group. Cambridge Assessment is the brand name of University of Cambridge Local Examinations Syndicate (UCLES), which is itself a department of the University of Cambridge.