

UNIVERSITY OF CAMBRIDGE INTERNATIONAL EXAMINATIONS  
General Certificate of Education Ordinary Level

**CHEMISTRY**

Paper 4 Alternative to Practical



**5070/04**

October/November 2005

**1 hour**

Candidates answer on the Question Paper.  
No Additional Materials are required.

Candidate  
Name

--

Centre  
Number

--	--	--	--	--

Candidate  
Number

--	--	--	--

**READ THESE INSTRUCTIONS FIRST**

Write your name, Centre number and candidate number in the spaces provided.  
Write in dark blue or black pen in the spaces provided on the Question Paper.  
You may use a pencil for any diagrams, graphs or rough working.  
Do not use staples, paper clips, highlighters, glue or correction fluid.

Answer **all** questions.  
The number of marks is given in brackets [ ] at the end of each question or part question.  
You should use names, not symbols, when describing all reacting chemicals and products formed.  
You may use a calculator.

DO NOT WRITE IN THE BARCODE.

DO NOT WRITE IN THE GREY AREAS BETWEEN THE PAGES.

If you have been given a label, look at the details. If any details are incorrect or missing, please fill in your correct details in the space provided.

Stick your personal label here, if provided.

**For Examiner's Use**

--

This document consists of **16** printed pages.



- 1 A student added hydrochloric acid to calcium carbonate to produce carbon dioxide using the apparatus shown below.

For  
Examiner's  
Use

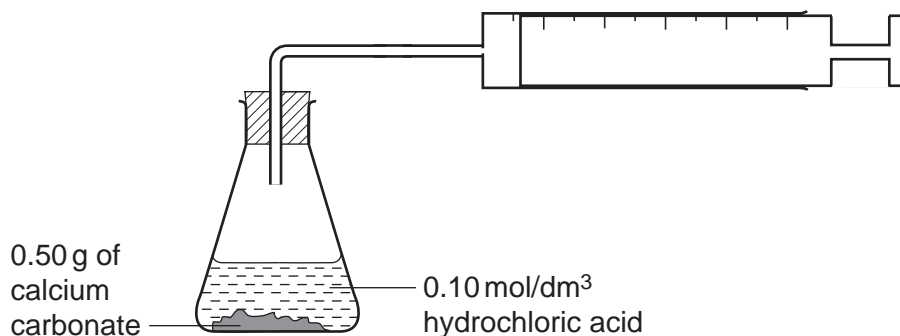

- (a) The diagram below shows the volume of carbon dioxide collected after one minute.

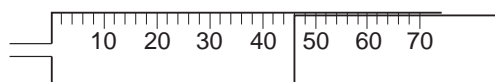

What volume of carbon dioxide was collected after one minute?

.....cm<sup>3</sup> [1]

- (b) Would the volume of carbon dioxide collected during the second minute be less than, the same, or more than the volume collected during the first minute? Explain your answer.

.....  
 .....  
 .....[2]

- (c) The equation for the reaction is

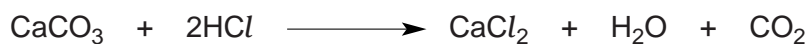

0.10 mol/dm<sup>3</sup> hydrochloric acid was added to 0.50g of calcium carbonate until no more carbon dioxide was produced.

- (i) Calculate the number of moles of calcium carbonate used in the experiment.  
 [A<sub>r</sub>; C, 12; O, 16; Ca, 40]

.....moles

(ii) Using your answer to (c)(i) calculate the minimum volume of 0.10 mol/dm<sup>3</sup> hydrochloric acid that was required to react with 0.50 g of calcium carbonate.

.....cm<sup>3</sup>

(iii) Calculate the maximum volume of carbon dioxide produced.  
1 mole of a gas measured at 25 °C has a volume of 24 dm<sup>3</sup>.

.....cm<sup>3</sup>  
[3]

(d) Suggest how the rate of this reaction could be increased by changing

(i) the physical state of calcium carbonate,

.....  
.....

(ii) the concentration of hydrochloric acid.

.....  
.....

[2]

- 2 A student did experiments to compare the reactivities of different metals. **M** and **N** are unknown metals. He was asked to suggest the identity of the two metals, **M** and **N**.

For  
Examiner's  
Use

- (a) Strips of different metals were placed in test-tubes half-filled with dilute sulphuric acid.

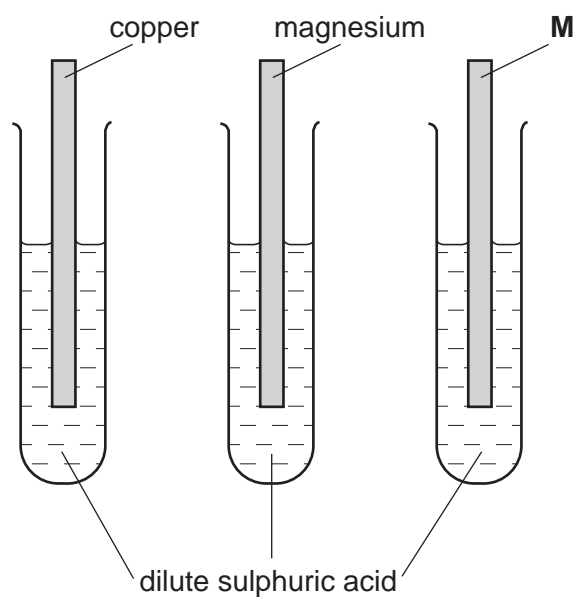

A gas was produced in **one** of the test tubes only.

- (i) Name the gas.
- (ii) Give a test for the gas.
- (iii) Which metal reacted with acid?
- (iv) Suggest, giving a reason, the identity of metal **M**.

[5]

(b) Six tubes were arranged as in the diagrams below. Each tube contained a piece of one metal half immersed in an aqueous solution containing ions of one of the other two metals.

There was a deposit in only **three** tubes including tube V.

There was **not** a deposit in tube VI.

For  
Examiner's  
Use

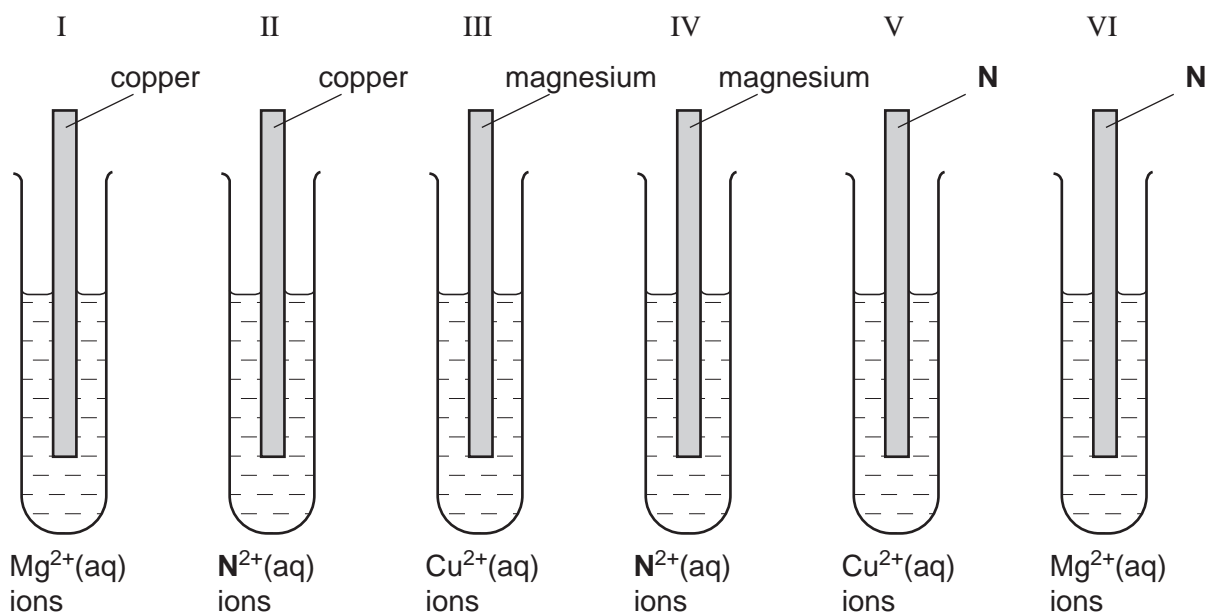

(i) In which three tubes was a deposit seen on the strip of metal?

(ii) Suggest, with a reason, what metal **N** could be.

(iii) Name the type of reaction which took place in tube V.

(iv) Name the products formed on heating the carbonate of **N** and write an equation for the reaction.

[6]

(c) A sample of iron oxide,  $\text{Fe}_2\text{O}_3$ , was heated with carbon.

For  
Examiner's  
Use

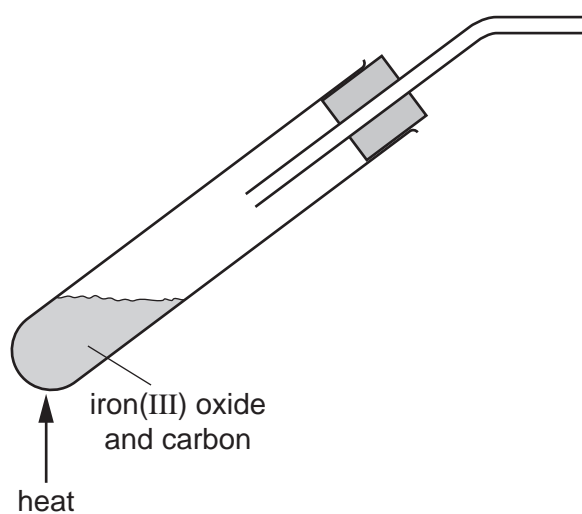

A reaction occurred and a gas was produced.

- (i) Name the gas that was produced.
  
  
  
  
  
  
  
  
  
  
- (ii) Give a test for this gas.
  
  
  
  
  
  
  
  
  
  
- (iii) Give an equation for the reaction.

[4]

For questions 3 to 6 inclusive, place a tick in the box against the best answer.

For  
Examiner's  
Use

3 A student made an ester by reacting an alcohol with an acid. Which one of the following produced an ester containing four carbon atoms?

(a) methanol and ethanoic acid

(b) ethanol and propanoic acid

(c) propanol and methanoic acid

(d) methanol and methanoic acid

[1]

4 Aqueous copper(II) sulphate was electrolysed using copper electrodes. The current was constant and the cathode was weighed at regular intervals.

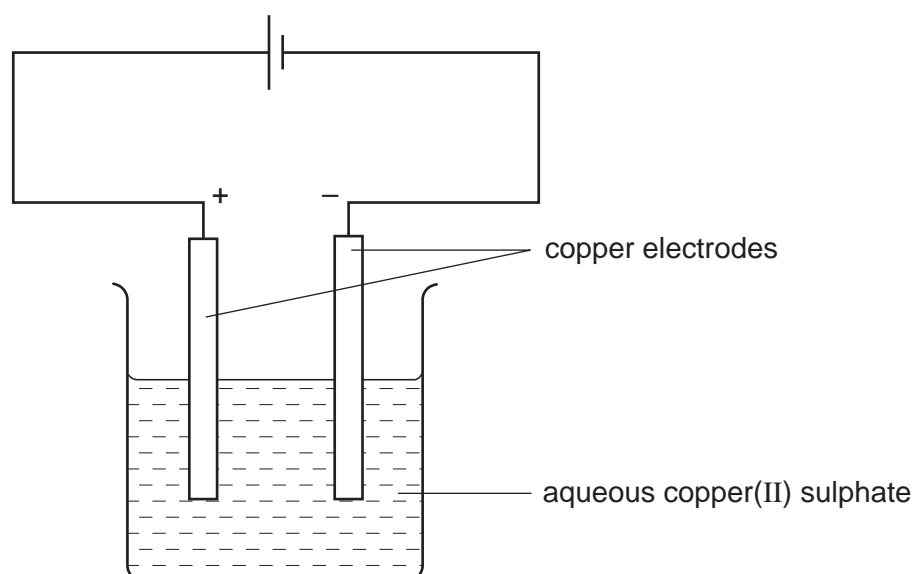

Which graph was obtained when the mass of the cathode was plotted against time?

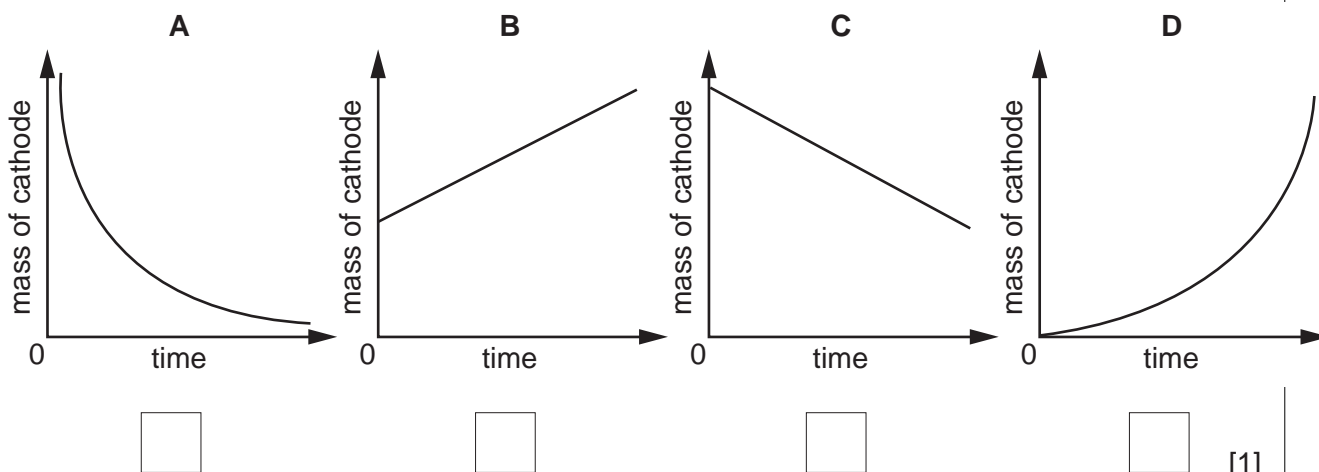

[1]

- 5 Five students each added hydrochloric acid from a burette to 25.0 cm<sup>3</sup> of aqueous sodium hydroxide that had been pipetted into a flask. The same indicator was used by each student. The results are shown in the table below.

For  
Examiner's  
Use

student	1	2	3	4	5
titration value / cm <sup>3</sup>	25.2	25.3	25.3	26.1	25.2

Which of the following could be a reason for the result obtained by student 4?

- (a) The burette was washed out with the hydrochloric acid.
- (b) The flask was washed out with the aqueous sodium hydroxide.
- (c) The student used too much indicator.
- (d) The pipette was washed out with the aqueous sodium hydroxide.

[1]



- 6 The apparatus shown below was used to determine the percentage by volume of oxygen in air.

The iron, on heating, combined with the oxygen in the air.

For  
Examiner's  
Use

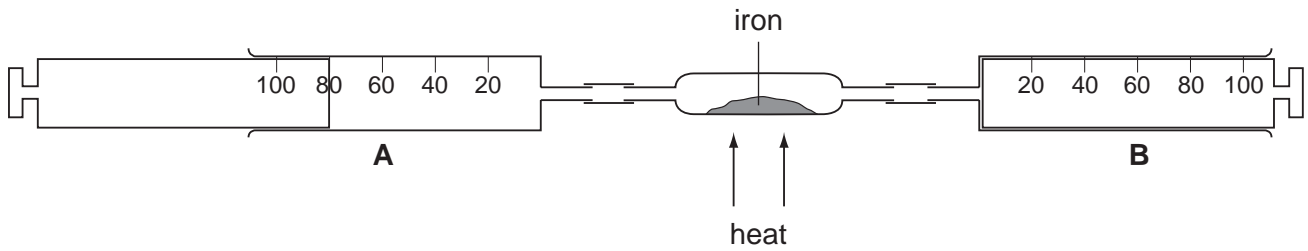

Syringe **A** contained  $80 \text{ cm}^3$  of air. The air was forced over heated iron into syringe **B**. The air in **B** was then forced back into syringe **A**. The process was repeated several times until the volume of the gas forced back into **A** was constant.

After allowing it to cool, what was the approximate volume of gas in the syringe **A** at the end of the experiment?

(a)  $16 \text{ cm}^3$

(b)  $20 \text{ cm}^3$

(c)  $64 \text{ cm}^3$

(d)  $80 \text{ cm}^3$

[1]

- 7 A student was given a sample of a metal hydroxide of formula,  $\text{B(OH)}_2$ .

The student was asked to identify the element **B** by titrating an aqueous solution of  $\text{B(OH)}_2$  with  $0.095 \text{ mol/dm}^3$  hydrochloric acid.

- (a) A sample of  $\text{B(OH)}_2$  was placed in a weighed container, which was reweighed.

$$\begin{array}{rcl} \text{mass of container + B(OH)}_2 & = & 10.94\text{g} \\ \text{mass of container} & = & 8.89\text{g} \end{array}$$

Calculate the mass of  $\text{B(OH)}_2$  used in the experiment.

.....g [1]

The sample of  $\text{B(OH)}_2$  was transferred to a flask and made up to  $250 \text{ cm}^3$  with distilled water. This was solution **S**.

$25.0 \text{ cm}^3$  of **S** was transferred to a conical flask.

A few drops of methyl orange indicator were added.

Hydrochloric acid was added from a burette until an end-point was reached.

- (b) What was the colour change at the end point?

The colour changed from .....to ..... [1]

Three titrations were done. The diagrams below show parts of the burette with the liquid levels before and after each titration.

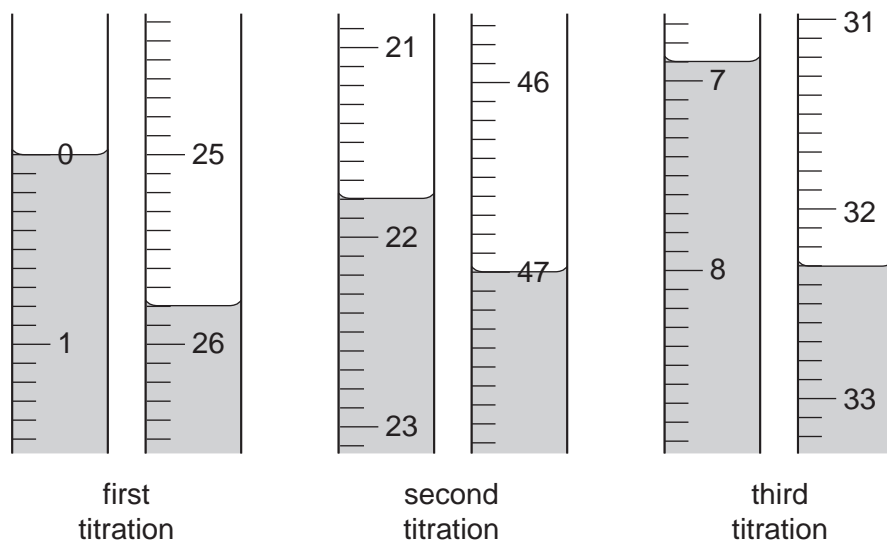

(c) Use the diagrams to complete the results table.

titration	first	second	third
final reading/cm <sup>3</sup>			
first reading/cm <sup>3</sup>			
volume of hydrochloric acid			
best titration results (✓)			

For  
Examiner's  
Use

Summary

Tick (✓) the best titration results.

The average volume of hydrochloric acid used was ..... cm<sup>3</sup>. [4]

(d) Calculate the number of moles in the average volume calculated in (c).

.....moles [1]

The equation for the reaction is shown.



(e) Using the equation and your answer to (d), calculate the number of moles of the alkali  $\text{B(OH)}_2$  in 25.0 cm<sup>3</sup> of **S**.

.....moles [1]

(f) How many moles of  $\text{B(OH)}_2$  were in the original 250 cm<sup>3</sup> of **S**?

.....moles [1]

(g) Using your answers (a) and (f) calculate the mass of one mole of  $\text{B}(\text{OH})_2$ .

For  
Examiner's  
Use

.....[1]

(h) (i) Using your answer (g) calculate the relative atomic mass of **B**.  
[ $A_r$ : H, 1; O, 16]

.....

(ii) Using the Periodic Table, suggest the identity of element **B**.

Element **B** is .....[2]

- 8 The following table shows the tests a student did on substance **V** and the conclusions made from the observations.

For  
Examiner's  
Use

Complete the table by describing these observations and identify the test used in **1(b)**.

test	observation	conclusion
<p><b>1 (a)</b> <b>V</b> was dissolved in dilute nitric acid and the solution divided into two parts for tests <b>2</b> and <b>3</b>.</p> <p><b>(b)</b> The gas produced was tested with .....</p>		<p>A gas was produced. <b>V</b> is a compound of a transition metal.</p> <p><b>V</b> contains <math>\text{CO}_3^{2-}</math> ions.</p>
<p><b>2 (a)</b> To the first part, aqueous sodium hydroxide was added until a change was seen.</p> <p><b>(b)</b> An excess of aqueous sodium hydroxide was added to the mixture from <b>(a)</b>.</p>		<p><b>V</b> may contain <math>\text{Fe}^{2+}</math> ions.</p>
<p><b>3 (a)</b> To the second part, aqueous ammonia was added until a change was seen.</p> <p><b>(b)</b> An excess of aqueous ammonia was added to the mixture from <b>(a)</b>.</p>		<p><b>V</b> contains <math>\text{Fe}^{2+}</math> ions.</p>

Conclusion: the formula for the compound **V** is .....[9]

- 9 A student investigated the temperature change produced when increasing amounts of powdered zinc were added to 50 cm<sup>3</sup> of 0.20 mol/dm<sup>3</sup> copper(II) sulphate in a beaker as shown in the diagram below.

For  
Examiner's  
Use

The initial temperature in each case was 25.0 °C.

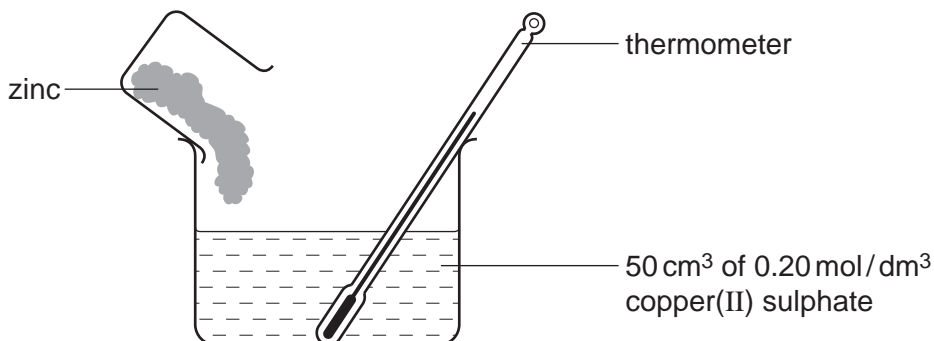

The diagrams below show the thermometer stems when the thermometer recorded the highest temperature reached after each addition of zinc.

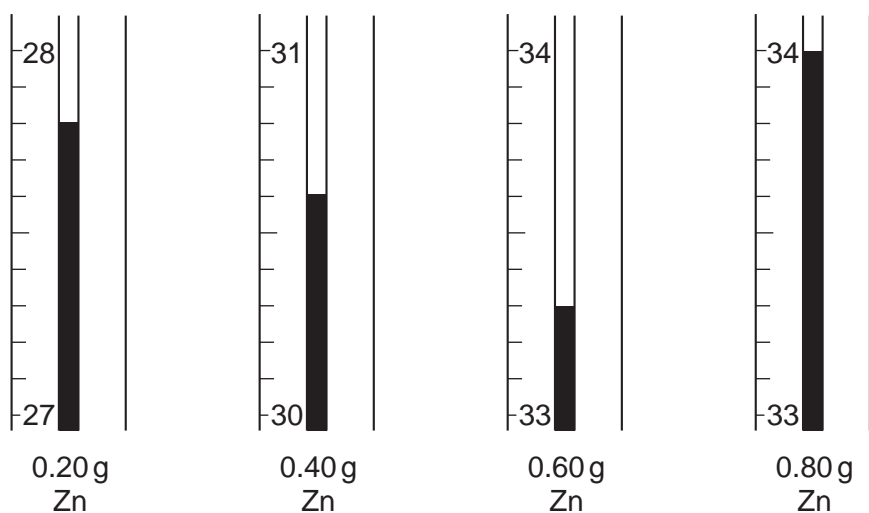

- (a) Use the diagrams to complete the table below.

volume / cm <sup>3</sup> of 0.20 mol / dm <sup>3</sup> copper(II) sulphate	mass / g of zinc	maximum temperature / °C	temperature rise / °C
50	0.2		
50	0.4		
50	0.6		
50	0.8		
50	1.0	34.0	

[2]

(b) Plot these results on the grid below and connect the points with two straight lines.

For  
Examiner's  
Use

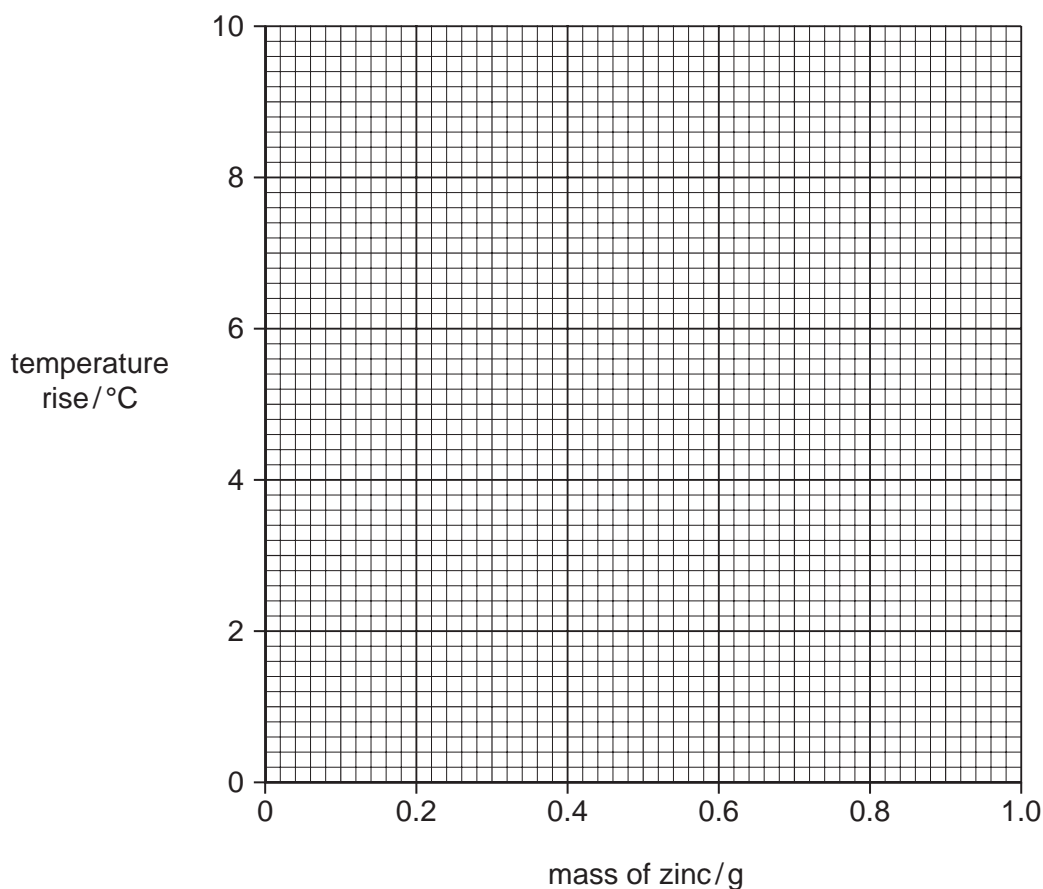

[3]

(c) (i) Use your graph to find the mass of zinc required to produce a temperature of 29.0 °C.

.....g

(ii) Deduce, from your graph, the mass of zinc required to react completely with 50 cm<sup>3</sup> of 0.20 mol/dm<sup>3</sup> copper(II) sulphate.

.....g

(iii) Why was the temperature rise the same in the last two experiments?

.....

.....

[3]

- (d) State two observations, other than a rise in temperature, which could be made when zinc reacted with aqueous copper(II) sulphate.

.....  
.....[2]

The experiment was repeated using iron instead of zinc. The volume and concentration of the copper(II) sulphate was the same.

- (e) What mass of iron was required to react completely with the copper(II) sulphate? Explain your answer.  
[A<sub>r</sub>: Fe, 56; Zn, 65.]

.....[2]