



UNIVERSITY OF CAMBRIDGE INTERNATIONAL EXAMINATIONS
International General Certificate of Secondary Education

TWENTY FIRST CENTURY SCIENCE (EXTENDED)

0608/02

Paper 2 Multiple Choice

October/November 2012

1 hour

Additional Materials: Multiple Choice Answer Sheet
 Soft clean eraser
 Soft pencil (type B or HB is recommended)



READ THESE INSTRUCTIONS FIRST

Write in soft pencil.

Do not use staples, paper clips, highlighters, glue or correction fluid.

Write your name, Centre number and candidate number on the Answer Sheet in the spaces provided unless this has been done for you.

There are **forty** questions on this paper. Answer **all** questions. For each question there are four possible answers **A, B, C** and **D**.

Choose the **one** you consider correct and record your choice in **soft pencil** on the separate Answer Sheet.

Read the instructions on the Answer Sheet very carefully.

Each correct answer will score one mark. A mark will not be deducted for a wrong answer.

Any rough working should be done in this booklet.

You may use a calculator.

This document consists of **15** printed pages and **1** blank page.



- 1 Which set of chromosomes should be used to correctly complete the genetic diagram?

	X	Y
X	XX	XY
X	XX	

- A** XY **B** XX **C** YY **D** XXXY

- 2 The family tree shows the inheritance of face freckles. The allele for the presence of face freckles is dominant.

Which individual must have the incorrect symbol?

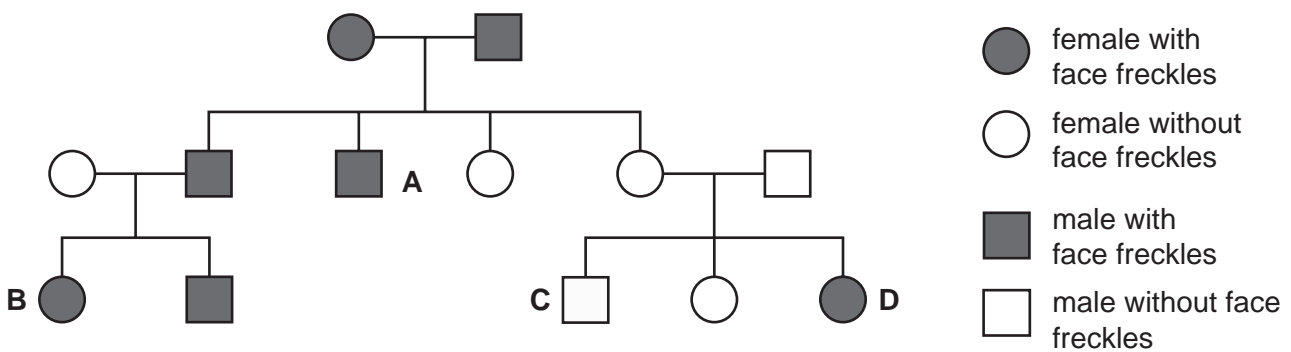

- 3 Turner syndrome is an unusual genetic disorder. People with this condition have only one sex chromosome in each cell. This is an X chromosome.

People with this condition have female characteristics.

What is the reason for this?

- A** Any person with an X chromosome is female.
B Male characteristics are controlled by a gene on the Y chromosome.
C The gene which produces female characteristics is dominant.
D Two Y chromosomes are needed in order to have male characteristics.
- 4 A woman is pregnant. Both parents of the foetus are carriers of cystic fibrosis. Which two of the following should they consider early in this pregnancy?
- 1 Whether or not to have the foetus tested for cystic fibrosis.
 - 2 Whether or not to have pre-implantation genetic diagnosis.
 - 3 Whether or not they would like to have boys or girls.
 - 4 Whether or not they would consider having the pregnancy terminated.

- A** 1 and 2 **B** 1 and 4 **C** 2 and 3 **D** 3 and 4

- 5 Cystic fibrosis is caused by a recessive allele.

The diagram shows the appearance of a chromosome with the recessive allele for cystic fibrosis in black.



Ben has cystic fibrosis and his mother is a carrier.

Which row shows the correct combination of chromosomes which Ben and his mother must have?

	Ben	Ben's mother
A		
B		
C		
D		

- 6 Identical twins occur when
- A** a sperm cell divides into two.
 - B** an egg cell is fertilised by two sperm cells.
 - C** cells of an embryo separate.
 - D** two different egg cells are fertilised.

7 Which statement about clones is true?

- A A clone has different genes from its parent.
- B Clones can be produced by asexual reproduction.
- C Environmental factors cannot cause differences between clones.
- D Two clones have different genes.

8 Natural processes take carbon dioxide out of the air.

Which process does **not** remove carbon dioxide from the air?

- A respiration by animals
- B dissolving in rain water
- C forming a solution in sea water
- D photosynthesis by plants

9 A scientist measures the concentration of sulfur dioxide in the air near a power station.

The table shows his results.

sample	1	2	3	4	5	6	7
concentration of sulfur dioxide in $\mu\text{g}/\text{m}^3$	610	598	604	623	355	630	595

Which statement about the results is correct?

- A It is not possible to calculate a best estimate from these results.
- B The mean of the results is $355 \mu\text{g}/\text{m}^3$.
- C The range of results is between 610 and $595 \mu\text{g}/\text{m}^3$.
- D There is an outlier in the results.

10 The diagrams show the arrangement of atoms in six molecules, 1, 2, 3, 4, 5 and 6.

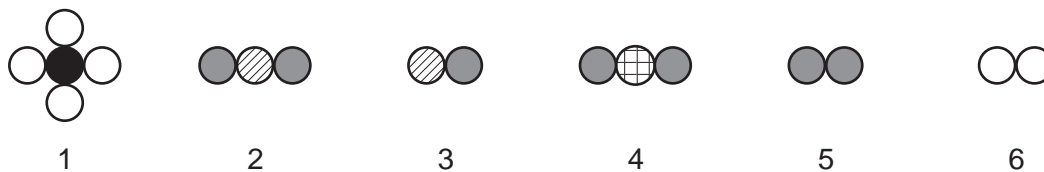

Which statement about the molecules is **not** correct?

- A 2 and 3 could be two different oxides of nitrogen.
- B If 1 is methane, CH₄, then 6 is hydrogen.
- C If 5 is oxygen, 4 could be water.
- D Two of the molecules are elements.

11 Which is a correctly balanced equation for the **incomplete** combustion of methane?

- A $\text{CH}_4 + 2\text{O}_2 \rightarrow \text{CO}_2 + 2\text{H}_2\text{O}$
- B $\text{CH}_4 + 2\text{O}_2 \rightarrow \text{CO} + 2\text{H}_2\text{O}$
- C $\text{CH}_4 + \text{O}_2 \rightarrow \text{C} + 2\text{H}_2\text{O}$
- D $2\text{CH}_4 + 2\text{O}_2 \rightarrow \text{CO} + \text{C} + 2\text{H}_2\text{O}$

12 Seafloor spreading produces patterns of magnetism in the ocean floors.

Which statement is **not** a part of the explanation for the patterns?

- A Molten magma solidifies at oceanic ridges at the boundary between tectonic plates.
- B Newly formed rocks move away from the oceanic ridge.
- C The Earth's magnetic field reverses direction.
- D Volcanoes are usually found at the edges of tectonic plates.

13 In 2000 some astronomers discovered a planet around the star Epsilon Eridani. The light from the star takes 10.5 years to reach the Earth.

How far is the star from Earth?

- A 3.4 light years
- B 7 light years
- C 10.5 light years
- D 380 light years

The following information should be used to answer questions **14** and **15**.

Some astronomers have reported finding Earth-like planets around a distant star.

Four scientists are discussing this report.

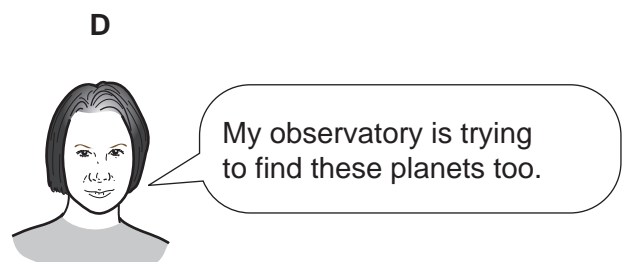
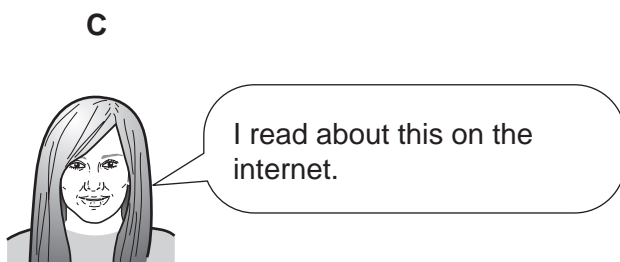
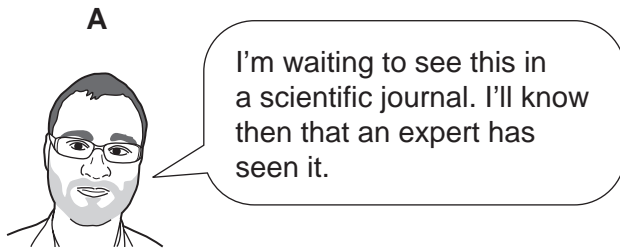

14 Which scientist is referring to peer review?

15 Which scientist is referring to replication of the research by the scientific community?

16 Against which group of microorganisms are antibiotics effective?

- A** bacteria and fungi only
- B** fungi and viruses only
- C** viruses and bacteria only
- D** bacteria, fungi and viruses

17 Over a period of time microorganisms can become resistant to antibiotics.

Which of these statements best explain how this can be prevented?

- 1 Only use antibiotics when necessary.
- 2 Ensure that antibiotics are fully tested before being used on patients.
- 3 Always complete a course of antibiotic treatment.
- 4 Return unused antibiotics to your doctor.

A 1 and 2

B 1 and 3

C 2 and 3

D 2 and 4

18 What should parents consider before vaccinating a child against a disease?

- 1 the chance of getting infected if not vaccinated
- 2 the chance of serious or irreversible harm occurring if not vaccinated
- 3 the various degrees of side-effects of the vaccine on different individuals

A 1, 2 and 3 B 1 only C 1 and 2 only D 2 and 3 only

19 What is the correct order for testing new drugs for safety and effectiveness?

- A healthy volunteers → ill patients → human cells
 B human cells → healthy volunteers → ill patients
 C human cells → ill patients → healthy volunteers
 D ill patients → human cells → healthy volunteers

20 Which statements about the structure and function of blood vessels are correct?

- 1 Arteries have thick muscular walls to carry blood under high pressure.
- 2 Veins have thin walls so that oxygen can diffuse in and out of the surrounding cells.
- 3 Capillaries have thin walls because they return all the blood back to the heart.
- 4 Veins have valves to prevent the blood flowing backwards.

A 1 and 2 B 1 and 4 C 2 and 3 D 3 and 4

21 Poly(propene) is a polymer that is used to make shampoo bottle tops.

The diagram shows the structure of poly(propene).

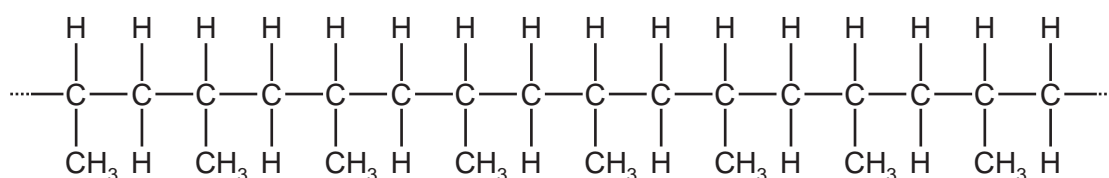

What is the structure of a **monomer** of poly(propene)?

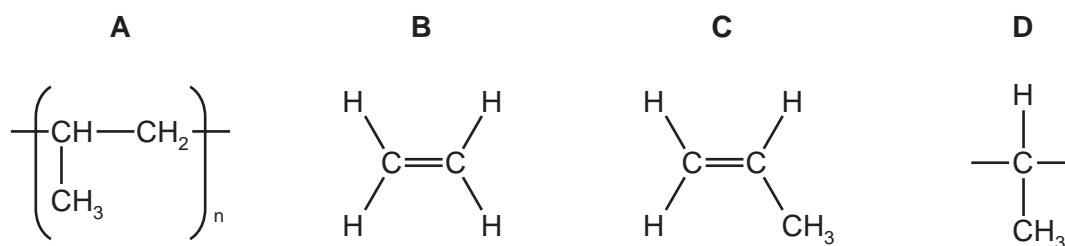

22 The table shows the range of tensile strength for each of four natural fibres.

	hemp	ramie	coir	sisal
tensile strength in N/mm ²	550-900	350-500	220-300	600-700

Which two fibres show no real difference in their tensile strengths?

- A coir and sisal
- B hemp and ramie
- C hemp and sisal
- D ramie and coir

23 Proteins are formed in cells.

Which statement about proteins is **not** correct?

- A Some proteins made in cells are stored in body fat.
- B Some proteins made in cells are used for cell growth.
- C Small molecules needed to make proteins are carried to the cells in the blood.
- D Cells use proteins to make tissue for muscles, tendons and skin.

24 Some packaging for fast food is made from cardboard and some is made from polystyrene.

Read the following statements.

- 1 Polystyrene is made from crude oil; cardboard is made from plant material.
- 2 Polystyrene packaging is more hardwearing than cardboard packaging.
- 3 Both types of packaging can be recycled into other products.
- 4 Polystyrene is non-biodegradable; cardboard rots away.
- 5 Polystyrene packaging is lighter to transport than cardboard packaging.

Which of the statements are about the sustainability of **making** packaging?

- A 1 only
- B 1 and 4 only
- C 1, 3, 4 and 5
- D 2 and 5

- 25 The two graphs show how the Earth's temperature and the concentration of carbon dioxide in the atmosphere have changed in the last 150 000 years.

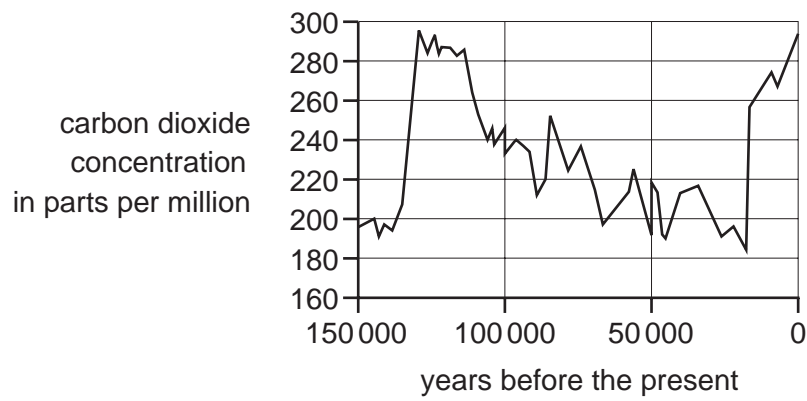
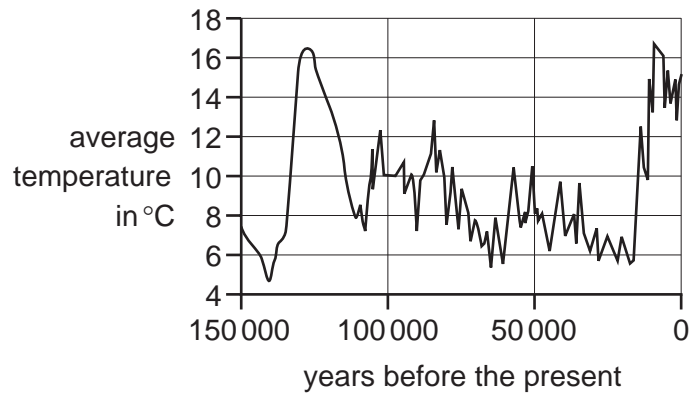

Which statement is a correct interpretation of this data?

- A** Increases in carbon dioxide concentration make the average temperature rise.
B Increases in the average temperature make the carbon dioxide concentration rise.
C There is no link between carbon dioxide concentration and average temperature.
D There is a correlation between carbon dioxide concentration and average temperature.
- 26 When you watch a TV, light travels from the TV screen to your eye.

Which row best describes the process happening?

	TV screen	air	eye
A	absorbs	emits	reflects
B	absorbs	reflects	transmits
C	emits	transmits	absorbs
D	emits	absorbs	transmits

27 Ultraviolet radiation from a source falls on the surfaces P and Q.

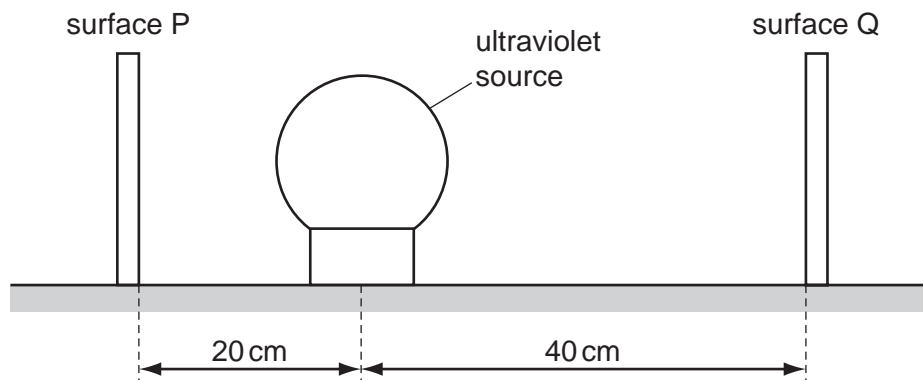

Why is the intensity of the ultraviolet radiation falling on surface Q less than the intensity falling on surface P?

- A Fewer photons hit surface Q than surface P each second.
- B Fewer photons hit surface Q than surface P each second and they have less energy.
- C The photons hitting surface Q are slower than those hitting surface P.
- D The photons hitting surface Q have less energy than those hitting surface P.

28 The table lists types of electromagnetic radiation and their approximate range of frequencies.

electromagnetic radiation	range of frequencies / Hz
radio waves	10^3 to 10^9
microwaves	10^9 to 10^{12}
infrared	10^{12} to 10^{14}
visible	10^{14} to 10^{15}
ultraviolet	10^{15} to 10^{18}
x-rays	10^{18} to 10^{20}
gamma rays	10^{20} to 10^{22}

Which range of frequencies includes ionising radiation?

- A 10^3 to 10^9 B 10^9 to 10^{12} C 10^{12} to 10^{15} D 10^{15} to 10^{22}

- 29 Some plants living in dry areas grow longer roots than other plants to reach deeper into the soil and find more water.

Which term best describes this?

- A competition
- B evolution
- C extinction
- D predation

- 30 Four students explain the difference between natural selection and selective breeding.

Which student gives the best explanation?

A



Natural selection is natural and selective breeding is selective.

B



Natural selection involves evolution but selective breeding does not.

C



Natural selection occurs in nature but selective breeding involves humans selecting the characteristics they want.

D



Natural selection usually happens more quickly than selective breeding.

The following information should be used to answer questions 31 and 32.

Humans (*Homo sapiens*) and other species evolved from a common ancestor.

Use the chart to answer the questions about human evolution.

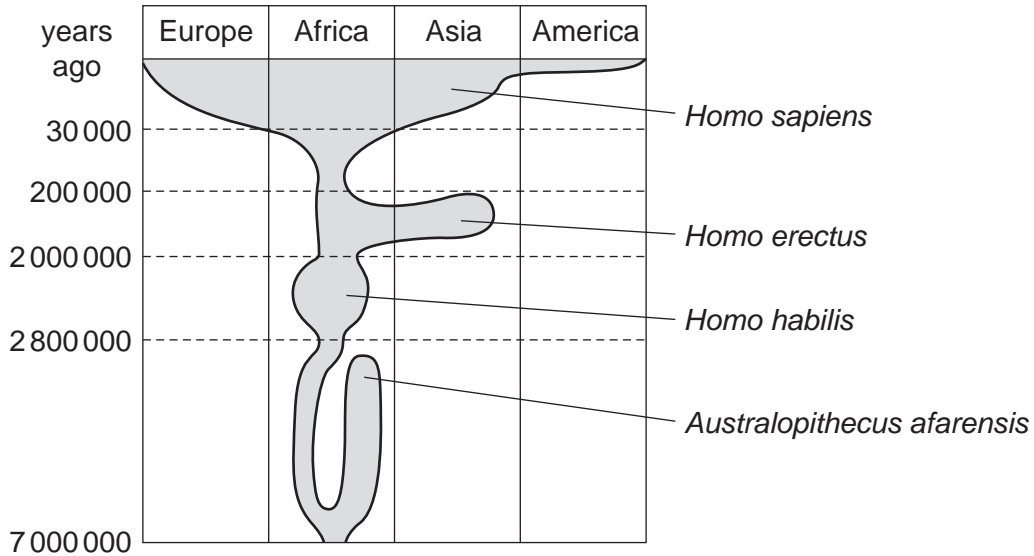

31 Which of these statements about human evolution are true?

- 1 *Homo sapiens* evolved from *Australopithecus afarensis*.
- 2 The common ancestor evolved in Africa.
- 3 *Homo erectus* is still alive today.
- 4 *Homo erectus* and *Homo sapiens* evolved from *Homo habilis*.

A 1 and 2 **B** 2 and 3 **C** 2 and 4 **D** 3 and 4

32 When did *Australopithecus afarensis* become extinct?

- A** less than 2 000 000 years ago
- B** after *Homo habilis*
- C** after *Homo sapiens*
- D** more than 2 800 000 years ago

The following information should be used for questions 33 and 34.

The table shows the average daily energy intake from food and energy output of four children.

	energy intake from food in kJ	energy output in kJ
Ally	8 000	7 500
Bee	4 000	7 000
Connor	10 000	4 000
David	8 000	8 200

33 Which child is most likely to be underweight?

- A Ally
- B Bee
- C Connor
- D David

34 Look at the information about Connor in the table.

Connor goes to see a doctor because he is worried about his general health.

What advice should the doctor give to Connor?

- A Connor needs to increase his daily energy intake from food.
- B Connor should drink more water.
- C Connor should be more active.
- D Connor should increase the amount of minerals in his diet.

35 Over time, land used to grow crops becomes less fertile.

Which statement gives the best explanation for this?

- A The carbon dioxide and water content of the soil decreases.
- B The concentration of amino acids in the soil decreases.
- C The acidity of the soil decreases.
- D The nitrogen, potassium and phosphorus content of the soil decreases.

36 Two friends are talking about eating naturally grown food.

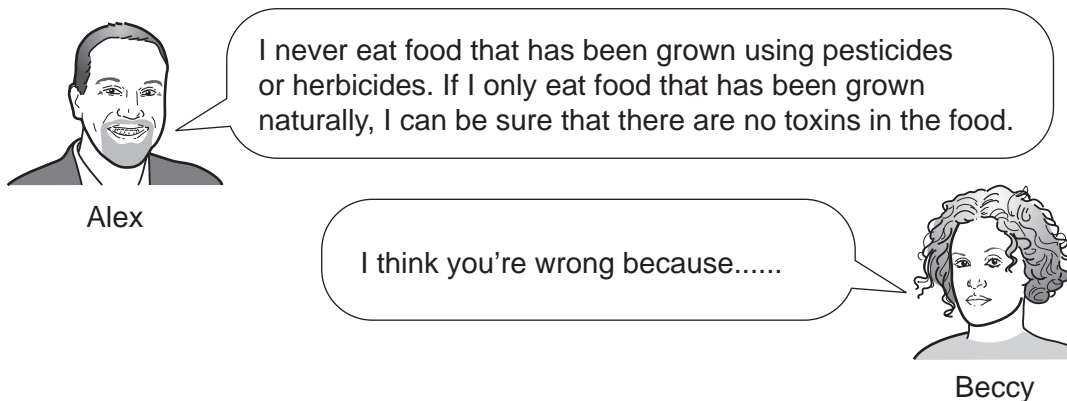

Which statement can Beccy use to support her view that Alex is wrong?

- A Food grown naturally does not always keep fresh as long.
- B Pesticides and herbicides help to increase the amount of food that farmers produce.
- C Some natural chemicals in food can be toxic.
- D Some pesticides and herbicides are not harmful.

37 The graph shows the radiation doses received by a person in one hour from four different sources.

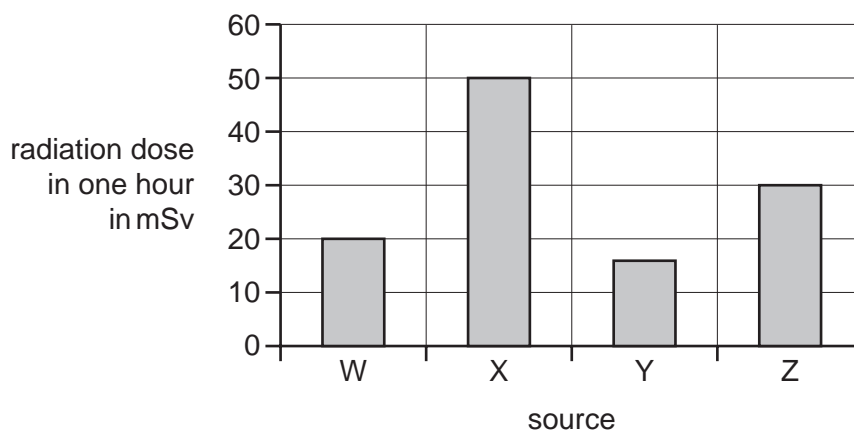

How many times more harmful is source Z than source W?

- A 0.67
- B 1.5
- C 10
- D 30

- 38 The graph shows the results of an experiment in which an increasing number of sheets of aluminium foil were placed between a radioactive source and a detector to investigate their effect on the count rate.

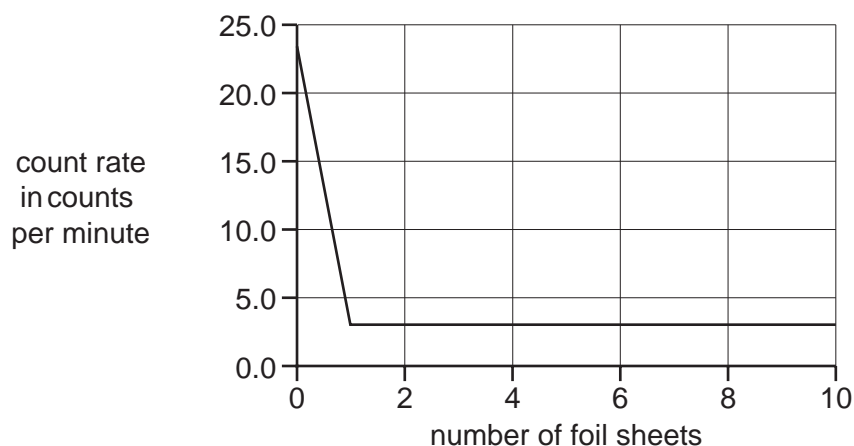

Which is the best conclusion for this experiment?

- A** One foil sheet reduces the count rate by 23 counts per minute.
B The background radiation is ten counts per minute.
C The source emits beta radiation only.
D The source emits gamma radiation only.
- 39 Which row correctly describes the roles of the parts of a nuclear reactor?

	fuel rod	control rod	coolant
A	removes heat from the reactor	speeds up the chain reaction	slows down the chain reaction
B	speeds up the chain reaction	slows down the chain reaction	removes heat from the reactor
C	where the chain reaction takes place	slows down the chain reaction	removes heat from the reactor
D	where the chain reaction takes place	speeds up the chain reaction	slows down the chain reaction

- 40 What is emitted during beta decay of a nucleus?

- A** a helium nucleus
B a neutron
C a proton
D an electron

BLANK PAGE

Permission to reproduce items where third-party owned material protected by copyright is included has been sought and cleared where possible. Every reasonable effort has been made by the publisher (UCLES) to trace copyright holders, but if any items requiring clearance have unwittingly been included, the publisher will be pleased to make amends at the earliest possible opportunity.

University of Cambridge International Examinations is part of the Cambridge Assessment Group. Cambridge Assessment is the brand name of University of Cambridge Local Examinations Syndicate (UCLES), which is itself a department of the University of Cambridge.