



UNIVERSITY OF CAMBRIDGE INTERNATIONAL EXAMINATIONS
International General Certificate of Secondary Education

CANDIDATE
NAME

CENTRE
NUMBER

| | | | | |
|--|--|--|--|--|
| | | | | |
|--|--|--|--|--|

CANDIDATE
NUMBER

| | | | |
|--|--|--|--|
| | | | |
|--|--|--|--|



TWENTY FIRST CENTURY SCIENCE

0608/05

Paper 5

May/June 2012

1 hour 30 minutes

Candidates answer on the Question Paper.

No Additional Materials are required.

READ THESE INSTRUCTIONS FIRST

Write your Centre number, candidate number and name on all the work you hand in.

Write in dark blue or black pen.

You may use a pencil for any diagrams or graphs.

Do not use staples, paper clips, highlighters, glue or correction fluid.

DO NOT WRITE IN ANY BARCODES.

Answer **all** questions.

At the end of the examination, fasten all your work securely together.

The number of marks is given in brackets [] at the end of each question or part question.

| For Examiner's Use | |
|--------------------|--|
| 1 | |
| 2 | |
| 3 | |
| 4 | |
| Total | |

This document consists of **13** printed pages and **3** blank pages.



Section A

1 Read this article.

Are electric cars the answer?

Cars and air pollution

Most cars are powered by an engine that burns petrol or diesel fuel. Exhaust gases from these cars contain the products of combustion of the fuel. These include carbon dioxide, carbon monoxide and carbon particulates. Exhaust gases also contain nitrogen monoxide, produced when nitrogen and oxygen react in the hot car engine.

Cars cause air pollution. This is serious in city centres, where the traffic density is high, and tall buildings prevent wind carrying the pollutant gases away. Many cities have traffic-free zones to reduce air pollution in central shopping areas. Others make drivers pay to enter the city in an effort to reduce traffic.

The chart on the left shows the number of cars produced worldwide from 2001 to 2011. The chart on the right shows the carbon dioxide concentration in the atmosphere for the same period.

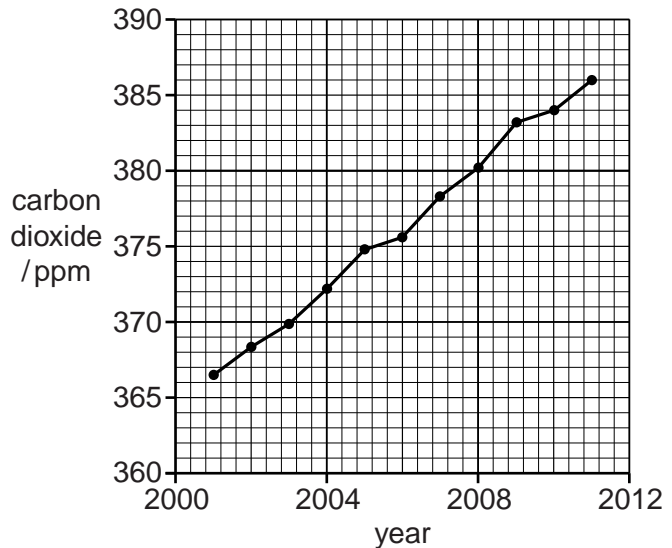
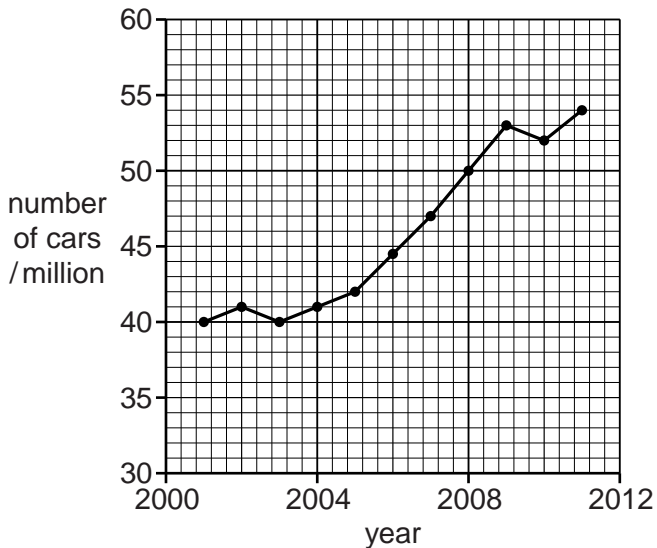

Electric cars

An electric car is powered by an almost silent electric motor that produces no exhaust gases. Electrical energy for the motor is supplied by a battery which has to be charged at regular intervals.

Electric cars are a possible solution to city centre air pollution but they do have some problems. They cannot travel very fast, or travel far without needing to be recharged.

Many people could plug in their cars to charge overnight, but this would be a problem for those living in apartments or other buildings without easy access from the car to an electric power point. For greater use of electric cars it would be necessary for cities to provide charging points in car parks and streets. Installation and maintenance costs could be high.

Overall effect on air pollution

Greater use of electric cars would reduce city centre air pollution, but the effect on overall air pollution, and on global warming, is less certain. Any reduction in air pollution would depend on the method used to generate the electricity that charges the car batteries. Many power stations burn fossil fuels, releasing carbon dioxide into the air. Some of these power stations also produce sulfur dioxide. A significant reduction in pollution from the use of electric cars will depend on how much electricity is generated by other methods.

(a) Use the charts to answer the following questions.

(i) What was the carbon dioxide concentration in the air in 2010?

..... ppm [1]

(ii) Estimate the carbon dioxide concentration in the air in 2012.

..... ppm [1]

(iii) Explain why the value you have given in **(ii)** may prove to be incorrect.

.....
..... [1]

(iv) Describe a correlation shown by the two charts.

.....
.....
.....
..... [2]

(b) The exhaust from cars using petrol engines releases carbon monoxide and carbon particulates.

(i) Explain how these two pollutants are produced by petrol engines.

.....
.....
..... [2]

(ii) Suggest reasons why these two pollutants are harmful.

.....
.....
..... [2]

(c) (i) A reaction inside a petrol engine produces nitrogen monoxide.

Write a **word equation** for this reaction.

..... [1]

(ii) When released into the air, nitrogen monoxide reacts to produce nitrogen dioxide.

Write a **balanced symbol equation** for this reaction.

..... [2]

(d) (i) Pollutant gases cause harm to humans directly and indirectly.

One example is sulfur dioxide.

Explain how sulfur dioxide causes harm to humans both directly and indirectly.

directly

.....

indirectly

..... [2]

(ii) Despite the harm caused by the pollutant gases released, millions of people drive petrol or diesel powered cars each day.

Use ideas about risk and benefit to explain why.

.....

.....

.....

.....

..... [4]

(e) The article says that air pollution may be particularly serious in city centres.

(i) Give two reasons why.

1.

2. [2]

(ii) Describe and explain **one** example of the efforts already made by some cities to reduce this air pollution.

.....

.....

..... [2]

(iii) Why may the use of electric cars provide a solution to city centre air pollution?

.....

.....

..... [2]

(iv) Electric cars may not give a big reduction in overall air pollution.

Explain why.

.....

.....

..... [2]

(f) More people who live in cities buy electric cars than people who live in the countryside.

Suggest **two** reasons why.

.....

.....

..... [2]

(g) Power stations burning fossil fuels release carbon dioxide into the air.

This is thought to be a cause of global warming.

The electricity for electric cars could be generated by methods that do not produce carbon dioxide.

Suggest two of these methods.

1.

2. [2]

[Total: 30]

Section B

- 2 Jenny is investigating the effect of four different concentrations of the same antibiotic on the growth of bacteria.

She soaks a small disc of paper in each of the four different concentrations of antibiotic.

She then places the discs of paper onto some nutrient jelly. The nutrient jelly is covered in bacteria and looks cloudy.

She leaves the nutrient jelly in a warm place for 24 hours.

After 24 hours, Jenny observes that a clear circle has appeared around the paper discs.

She measures the distance, **d**, from the centre of each paper disc to the outer edge of the clear circle.

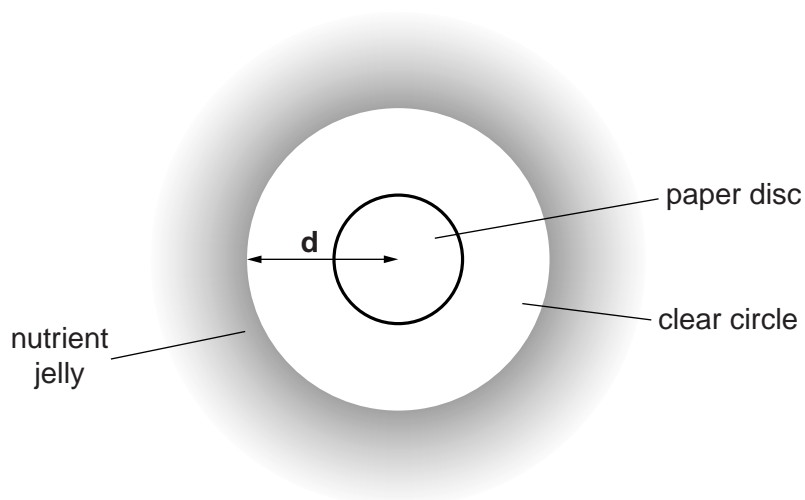

- (a) Jenny used paper discs of the same diameter at each antibiotic concentration.

Explain why.

.....

.....

..... [2]

- (b) Suggest why Jenny left the experiment for 24 hours before measuring her results.

.....

.....

..... [2]

(c) The table shows Jenny's results.

| antibiotic concentration /% | distance, d /mm |
|--------------------------------|---------------------------|
| 100 | 16 |
| 75 | 12 |
| 50 | |
| 25 | 4 |

Jenny looks at the disc for 50% antibiotic concentration.

Jenny measures the distance from the centre of the paper disc to the outer edge of the clear circle.

She measures to the nearest mm.

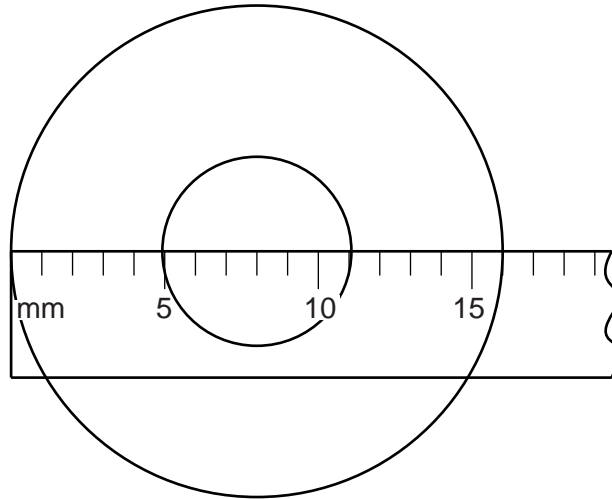

(i) Name the apparatus Jenny uses to make this measurement.

..... [1]

(ii) What is Jenny's measurement at 50% antibiotic concentration?

..... mm [1]

(d) What conclusions about the action of antibiotics on bacteria can be made from Jenny's results?

.....

 [2]

- (e) Paul suggests to Jenny that she should repeat the experiment using water as well as the antibiotic solutions.

*For
Examiner's
Use*

Jenny thinks this is a waste of time. She says that water does not have any effect on bacteria.

Explain why Paul is correct.

.....

.....

..... [2]

[Total: 10]

3 Some radioactive materials emit beta radiation.

Alan and Bella are doing an experiment to investigate the absorption of beta radiation by aluminium.

Their experiment is set up as shown in the diagram.

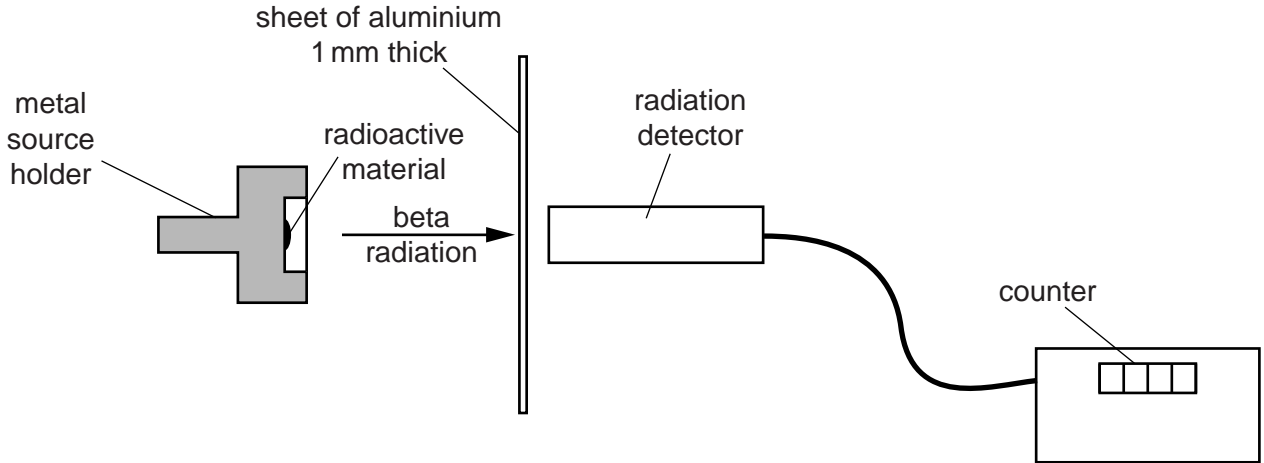

The counter display shows how much radiation has reached the radiation detector.

Alan and Bella have a large number of sheets of aluminium, each 1 mm thick.

They need to measure how much radiation per second gets through different numbers of sheets of aluminium.

(a) What other piece of apparatus will they need?

Put a ring around the correct answer.

- balance (scales)**
- measuring cylinder**
- stop watch**
- thermometer**
- [1]

(b) Beta radiation is an ionising radiation. It can be harmful.

There is a risk involved in using beta radiation.

Suggest and explain one precaution that Alan and Bella should take to make the risk as low as possible for themselves and for other students in the room.

.....

.....

..... [2]

(c) The diagram below shows the display on the counter at two times in the experiment.

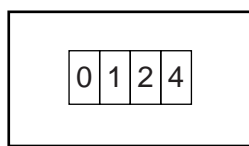

at the start

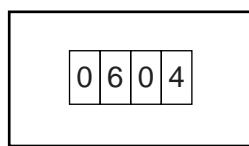

10 seconds later

(i) What was the increase in the count between these two times?

increase in count = [1]

(ii) Use your answer to (c)(i) to calculate the number of counts per second.

number of counts per second = [1]

(d) Bella and Alan obtain this set of data.

| | | | | | | |
|-------------------------------|----|----|----|----|----|----|
| number of sheets of aluminium | 0 | 1 | 2 | 3 | 4 | 5 |
| number of counts per second | 65 | 60 | 48 | 36 | 25 | 19 |

Describe in detail what the results show.

.....

 [2]

(e) Bella and Alan repeat their experiment several times.

Explain why this is a good idea.

.....
 [1]

- (f) When the counter is switched on without any radioactive source nearby, background radiation gives an average count of 120 counts in a minute.

For
Examiner's
Use

Bella and Alan need to correct their results to allow for this background radiation.

Explain how they do this to get the number of counts per second coming from the radioactive source.

.....

.....

.....

..... [2]

[Total: 10]

Question 4 begins on page 12.

- 4 Scientists measure the nitrogen dioxide concentration at different distances from a busy road.

At each distance they take five samples of air. From these samples they obtain a best estimate of the nitrogen dioxide concentration.

- (a) The measurements taken by the scientists at a distance of 10 metres are shown in Table 1.

Table 1

| | | | | | |
|--|----|----|----|----|----|
| sample number | 1 | 2 | 3 | 4 | 5 |
| nitrogen dioxide concentration in $\mu\text{g}/\text{m}^3$ | 42 | 40 | 48 | 44 | 46 |

Use these measurements to work out a best estimate for the concentration of nitrogen dioxide at 10 m.

Show your working below.

best estimate = $\mu\text{g}/\text{m}^3$ [2]

- (b) Table 2 shows the best estimate at each distance.

Write your value from (a) into this table.

Table 2

| | | | | | | |
|---|-----|----|----|----|----|----|
| distance in m | 2 | 4 | 6 | 8 | 10 | 12 |
| best estimate of nitrogen dioxide concentration in $\mu\text{g}/\text{m}^3$ | 102 | 89 | 70 | 56 | | 28 |

- (i) On the grid opposite the axis for nitrogen dioxide concentration has been drawn for you.
Draw and label the axis for distance. [2]
- (ii) Plot the data from Table 2 on the grid. [2]
- (iii) Draw a best-fit straight line. [1]

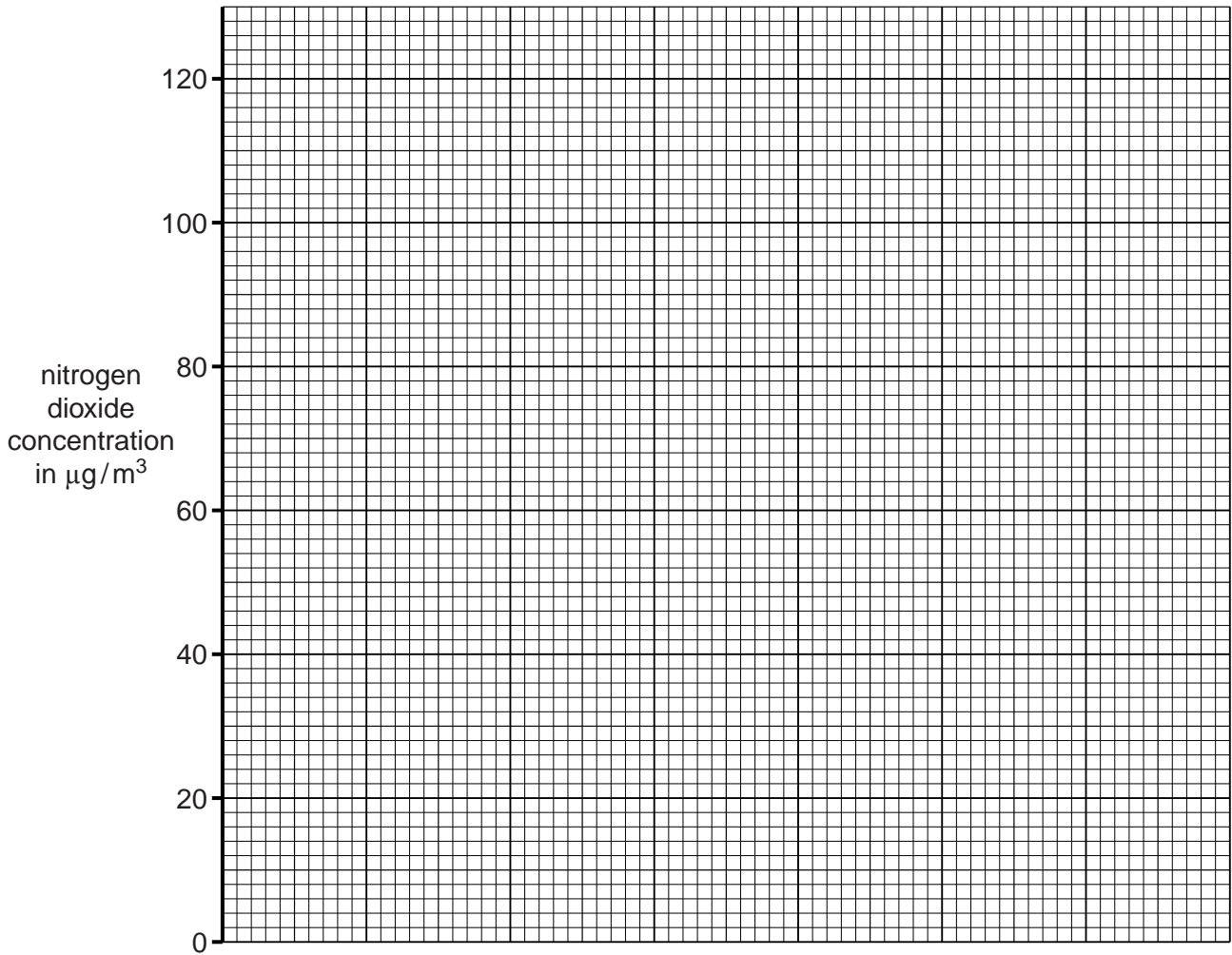

- (c) Use your graph to find the nitrogen dioxide concentration at a distance of 5 m from the road.

nitrogen dioxide concentration = $\mu\text{g}/\text{m}^3$ [1]

- (d) Use your graph to estimate the nitrogen dioxide concentration at a distance of 0 m from the road.

nitrogen dioxide concentration = $\mu\text{g}/\text{m}^3$ [2]

[Total: 10]

BLANK PAGE

Permission to reproduce items where third-party owned material protected by copyright is included has been sought and cleared where possible. Every reasonable effort has been made by the publisher (UCLES) to trace copyright holders, but if any items requiring clearance have unwittingly been included, the publisher will be pleased to make amends at the earliest possible opportunity.

University of Cambridge International Examinations is part of the Cambridge Assessment Group. Cambridge Assessment is the brand name of University of Cambridge Local Examinations Syndicate (UCLES), which is itself a department of the University of Cambridge.