



UNIVERSITY OF CAMBRIDGE INTERNATIONAL EXAMINATIONS
International General Certificate of Secondary Education

CANDIDATE
NAME

CENTRE
NUMBER

--	--	--	--	--

CANDIDATE
NUMBER

--	--	--	--



CO-ORDINATED SCIENCES

0654/63

Paper 6 Alternative to Practical

October/November 2011

1 hour

Candidates answer on the Question paper

No Additional Materials are required.

READ THESE INSTRUCTIONS FIRST

Write your Centre number, candidate number and name on all the work you hand in.

Write in dark blue or black pen.

You may use a soft pencil for any diagrams, graphs, tables or rough working.

Do not use staples, paper clips, highlighters, glue or correction fluid.

DO NOT WRITE IN ANY BARCODES.

Answer **all** questions.

At the end of the examination, fasten all your work securely together.

The number of marks is given in brackets [] at the end of each question or part question.

For Examiner's Use	
1	
2	
3	
4	
5	
6	
Total	

This document consists of **18** printed pages and **2** blank pages.



1 Fig. 1.1 shows the upper and lower surfaces of a leaf after being placed into boiling water.

For
Examiner's
Use

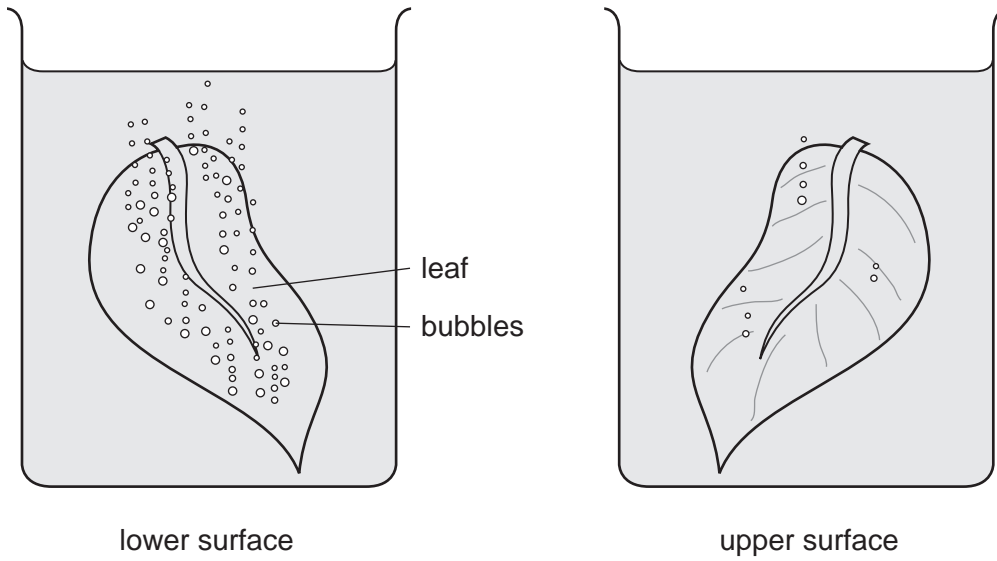

Fig. 1.1

(a) (i) Explain why bubbles are produced.

.....

.....

..... [2]

- (ii) A second leaf was taken and its outline traced onto a piece of 15 cm x 15 cm squared paper. This tracing is shown in Fig. 1.2.

For
Examiner's
Use

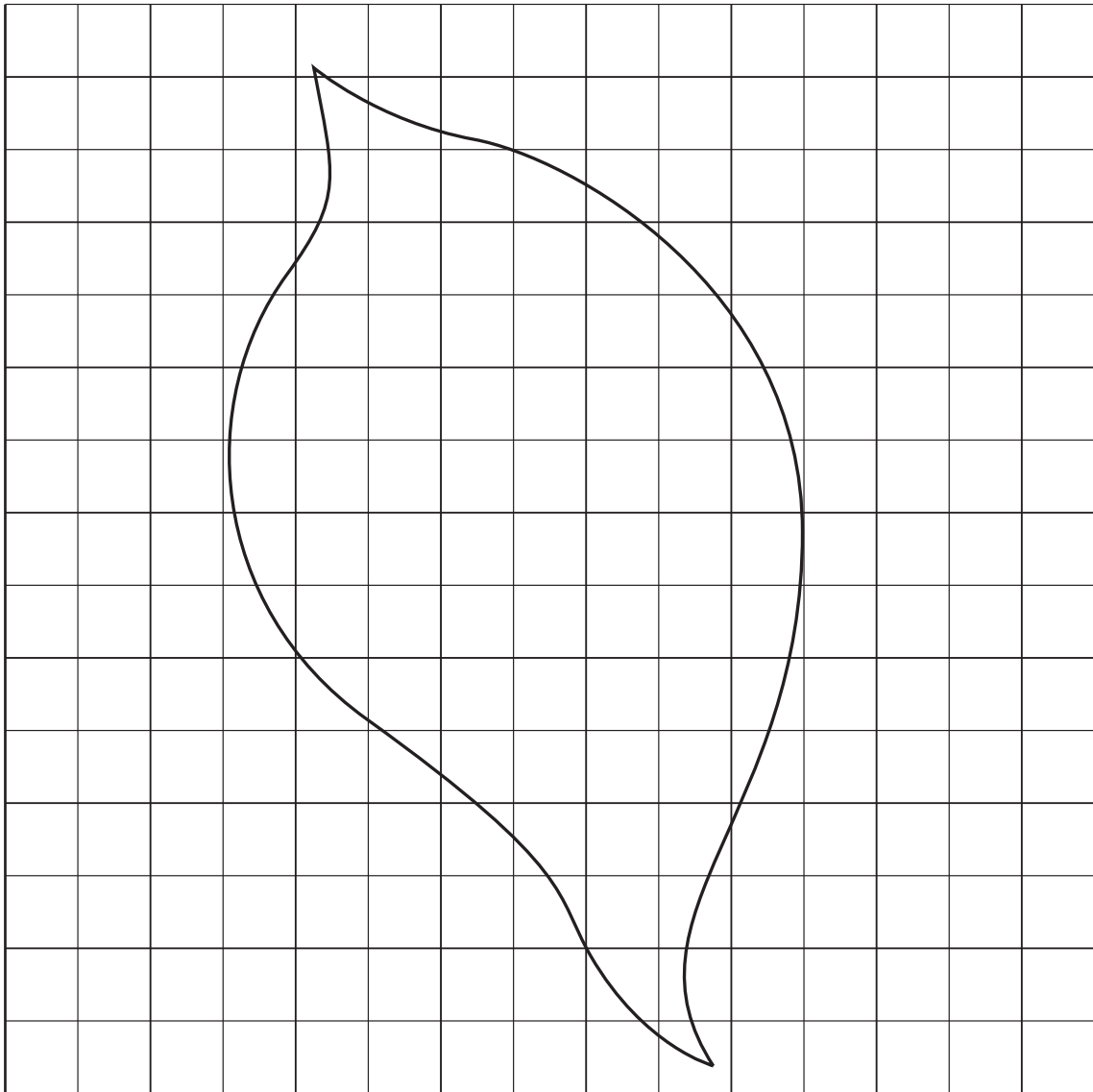

Fig. 1.2

- Write the letter **C** in the **complete** squares. Count the number of complete squares.

number of complete (**C**) squares = [1]

- Write the letter **P** in any incomplete squares that have an area of half a square or more.

number of incomplete (**P**) squares = [1]

- Ignore the rest of the squares.
- Add **C + P** to estimate the area of the leaf. You will use your answer in **(a)(iii)**.

leaf area = cm²

- (iii) There are approximately 100 stomata per **square millimetre** on the lower surface of this leaf.

Using the leaf surface area you have determined (a)(ii), calculate the total number of stomata found on the lower surface of the leaf.

area of leaf in mm² =

total number of stomata = [2]

- (iv) There are usually fewer stomata found on the upper surface of a leaf.

Suggest why this is beneficial to a plant.

.....
.....
..... [2]

- (b) Fig. 1.3 shows an outline cross section of a piece of celery. The celery has been placed into red dye for 4 hours.

On Fig. 1.3, shade the areas to show where you would expect the red dye to be found.

Label the shaded areas with the correct name for this tissue.

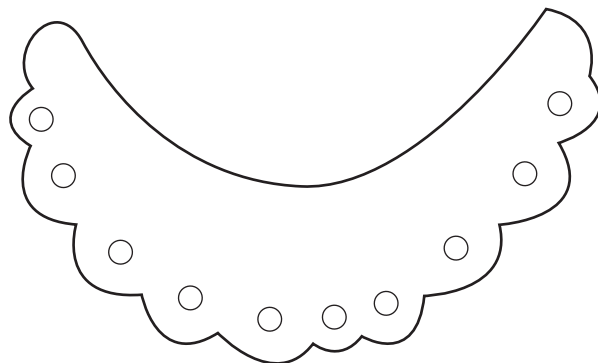

Fig. 1.3

[2]

- 2 The science class is investigating the properties of carbon dioxide. They are using the apparatus shown in Fig. 2.1 to make and test the gas. They carry out three experiments.

For
Examiner's
Use

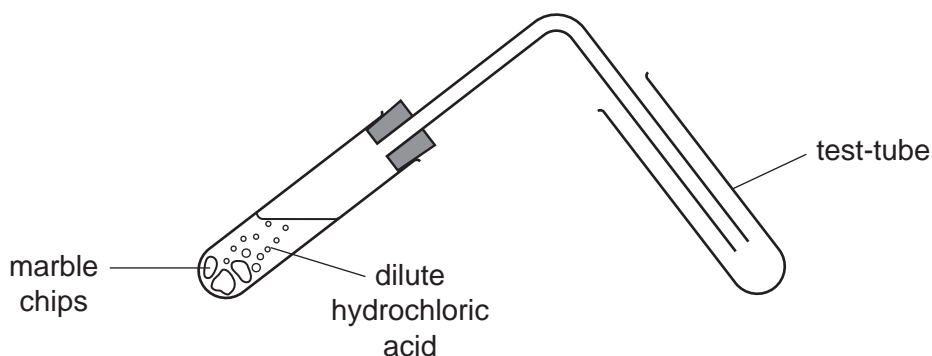

Fig. 2.1

Experiment 1

They place about 3 cm³ of distilled water in a test-tube and add a few drops of Universal Indicator. They then let the carbon dioxide bubble through the water and Universal Indicator. They see a colour change. They decide that a weak acid has been formed in the test-tube.

(a) (i) The colour changes from to [2]

(ii) Name the weak acid in the test-tube.

..... [1]

Experiment 2

They wash out the test-tube and half-fill it with limewater. They bubble in carbon dioxide.

(b) (i) What does the class observe in the tube at first?

..... [1]

(ii) What does the class observe in the tube after more carbon dioxide has been bubbled in?

..... [1]

The teacher gives the class two equations for the reactions they observed in **(b)(i)** and **(b)(ii)**.

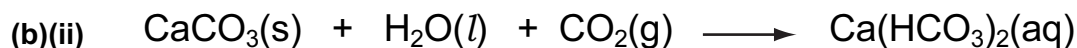
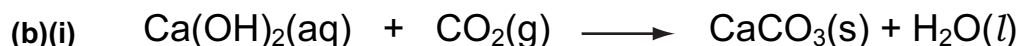

(iii) Explain the meaning of the symbols used in the equations.

(aq) means

(g) means

(s) means [3]

(iv) Insert **one** word to complete the following sentence, to explain what happens when carbon dioxide is bubbled into limewater.

There is a of calcium carbonate which dissolves
when more carbon dioxide is bubbled in. [1]

Experiment 3

The class use the apparatus in Fig. 2.1 to collect carbon dioxide in a clean dry test tube. They insert a lighted splint into the test-tube of carbon dioxide. The flame is extinguished.

(c) Choose **two** correct statements from lines **A**, **B**, **C** and **D** below.

A Carbon dioxide burns in air.

B Carbon dioxide does not support combustion.

C Carbon dioxide does not burn in air.

D Carbon dioxide supports combustion.

The two correct statements are lines and [1]

- 3 A student is finding the resistances of single and parallel wires using the circuit shown in Fig. 3.1.

For
Examiner's
Use

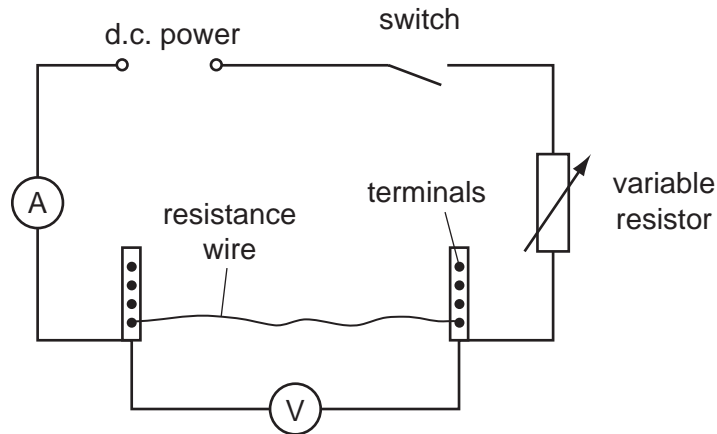

Fig. 3.1

- She connects a 25 cm length of resistance wire between the terminals.
- She closes the switch and notes the readings on the ammeter and voltmeter, and records them in Table 3.1.
- She opens the switch and then connects a second piece of resistance wire so that there are 2 identical wires in parallel between the terminals.
- She closes the switch and records the new ammeter and voltmeter readings.
- She finds the ammeter and voltmeter readings using 3 and 4 wires in parallel, recording them in Table 3.1 over the page.

(a) The ammeter and voltmeter readings for 2 wires in parallel are shown in Fig. 3.2.

(i) Read the ammeter and voltmeter and record the values in Table 3.1. [2]

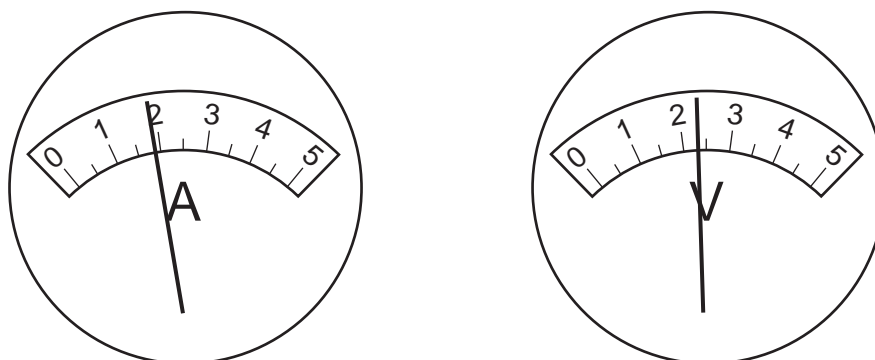

Fig. 3.2

(ii) Calculate the resistances for 2 wires and 3 wires in parallel.

Record them in the last column of Table 3.1.

Use the formula

$$\text{resistance in ohms} = \frac{\text{potential difference in volts}}{\text{current in amps}}$$

[2]

Table 3.1

number of resistance wires	current / A	potential difference / V	total resistance / ohms
1	1.0	2.5	2.5
2			
3	2.5	2.0	
4	3.2	1.9	0.6

(b) (i) Plot a graph of total resistance/ohms (vertical axis) against number of wires.

Draw a smooth curve, extending it so that the resistance of 5 wires in parallel can be read.

For
Examiner's
Use

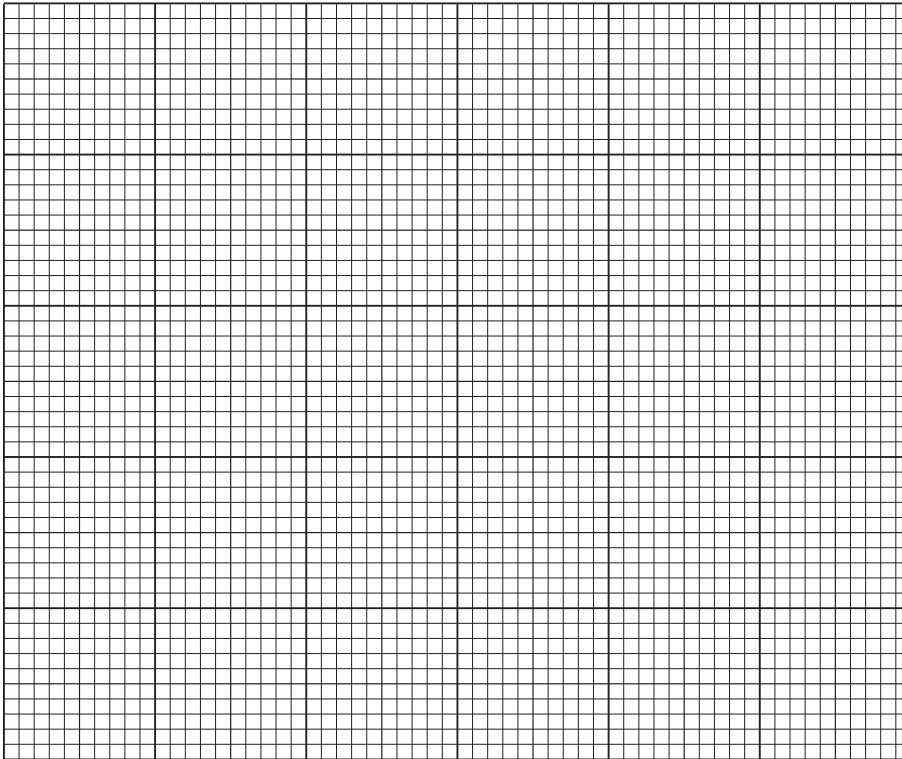

[3]

(ii) Use your graph to find the resistance of 5 wires in parallel.

Show how you do this on the graph.

resistance of 5 wires in parallel = ohms [2]

(c) The student is not satisfied that the resistance she calculated for 1 wire is accurate.

Suggest how she can find a more reliable value using the same apparatus.

.....
.....
..... [1]

- 4 (a) A student carried out an experiment to investigate the effect of change of temperature on the activity of the enzyme pepsin.

For
Examiner's
Use

Pepsin breaks down protein in the stomach. Its activity can be measured by timing how long it takes to break down a cloudy protein solution. The solution becomes clear.

- The student put 5.0 cm^3 of the protein solution into a test-tube and added 1.0 cm^3 hydrochloric acid.
- He put 1 cm^3 of pepsin solution into another test-tube.
- He put both test-tubes into a water bath set at $35 \text{ }^\circ\text{C}$ until they both reached this temperature.
- He then poured the pepsin solution into the protein solution and timed how long it took for the mixture to go clear. He recorded his results in Table 4.1.
- The student repeated this procedure for each temperature.

Table 4.1

temperature / $^\circ\text{C}$	time taken for mixture to go clear / min	$\frac{1}{\text{time taken}} / \frac{1}{\text{min}}$
35	6.8	0.15
40	2.9	0.34
45	1.3	
50	0.5	2.00
55	2.0	
60	7.2	0.14

Find the reciprocal of the time taken ($1 / \text{time taken}$) for the temperatures $45 \text{ }^\circ\text{C}$ and $55 \text{ }^\circ\text{C}$. This is a measure of the rate of reaction. Enter your results in Table 4.1.

[2]

- (b) (i) Plot the points to draw a graph of $1 / \text{time taken}$ against temperature on the grid provided. Draw a smooth curve through your points.

For
Examiner's
Use

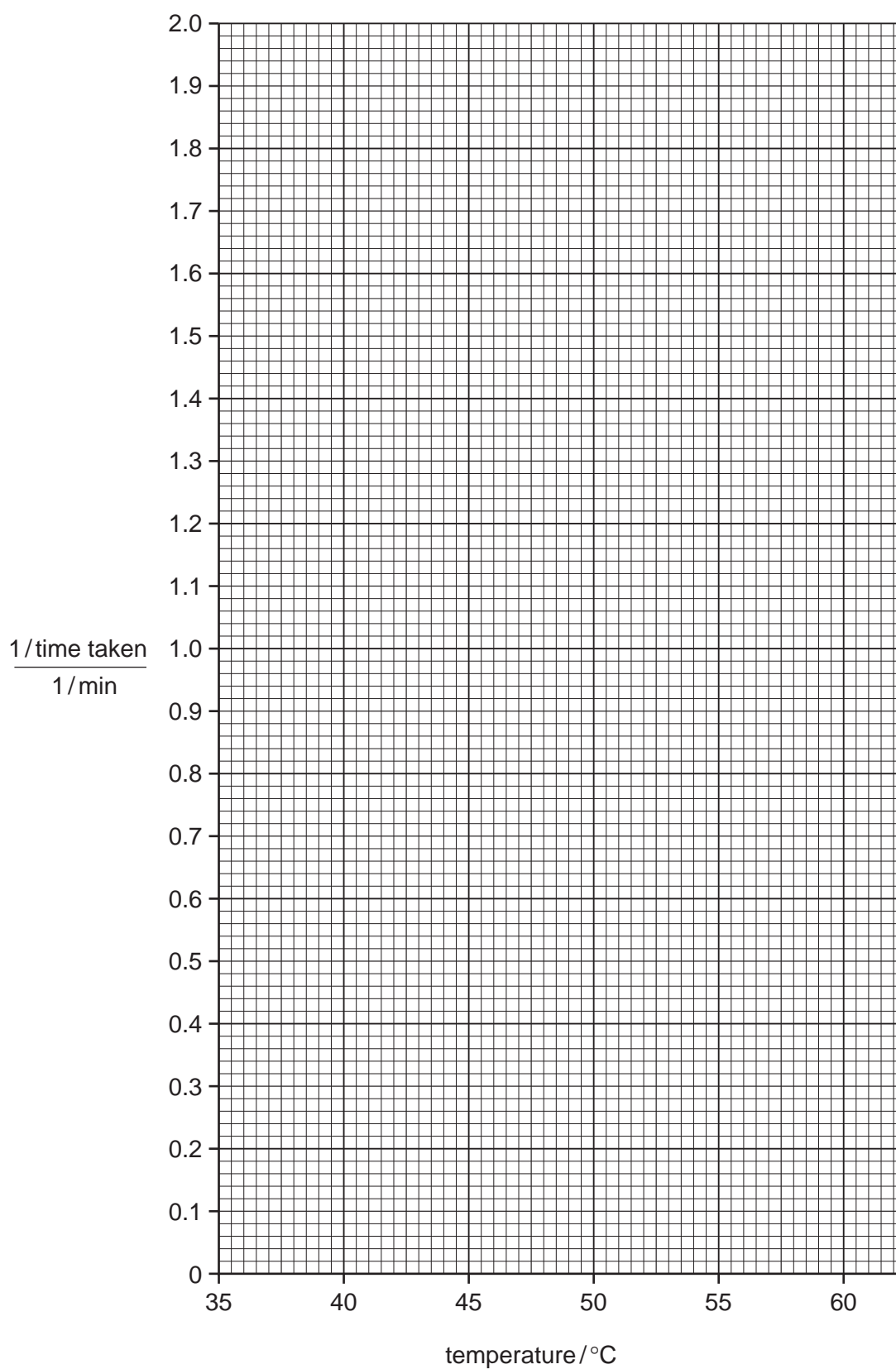

[2]

(ii) Use the graph to estimate the optimum temperature for the activity of pepsin.

..... °C [1]

(iii) Explain why you cannot be sure that this is an accurate optimum temperature.

..... [1]

(c) Use your knowledge of enzyme action to explain the results

(i) between 35 - 45 °C,

.....
.....
..... [1]

(ii) between 55 - 60 °C.

.....
.....
..... [1]

(d) The student suggested that there should be another two tubes set up for each temperature.

tube 1

5.0 cm³ of the protein solution + 1 cm³ water + 1 cm³ pepsin solution

tube 2

5.0 cm³ of the protein solution + 1 cm³ hydrochloric acid + 1 cm³ water

Explain the purposes of **tube 1** and **tube 2**.

tube 1
.....
.....

tube 2
.....
..... [2]

5 A student is investigating the dyes contained in three inks, 1, 2 and 3.

He has put spots of the inks on the start line that he has marked on a piece of chromatography paper. He has formed the paper into a tall cylinder. His arrangement is shown in Fig. 5.1.

For
Examiner's
Use

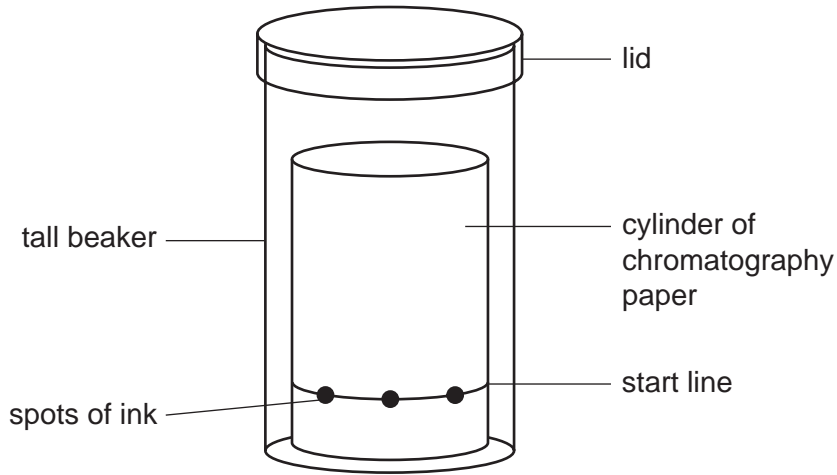

Fig. 5.1

The student is now ready to pour some liquid into the tall beaker to separate the dyes in the inks.

(a) (i) Name a liquid that he can use to separate the dyes in the inks.

..... [1]

(ii) On Fig. 5.1, draw a line to show how much of this liquid the student must place in the beaker. [1]

(iii) Explain why a lid must be placed on the beaker.

.....
..... [1]

(iv) Suggest the length of time that should be allowed for the dyes to separate.

..... mins [1]

Fig. 5.2 shows the results of the experiment.

For
Examiner's
Use

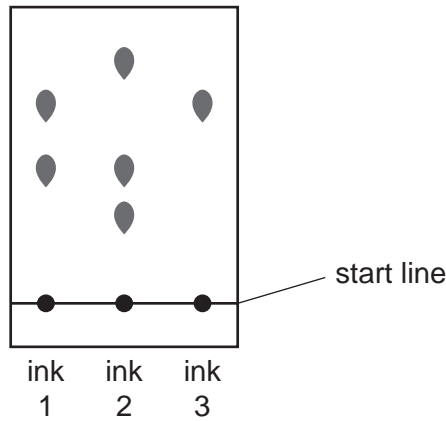

Fig. 5.2

(b) Suggest **one** conclusion that can be made by comparing the spots obtained from each of

(i) ink 1 and ink 2,

.....
..... [1]

(ii) ink 2 and ink 3.

.....
..... [1]

(c) The student thinks that one of the three dyes contained in ink 2 may act as an acid-base indicator.

Describe how he can find out which of the three dyes will act as an indicator.

Name **two** reagents that he can use in this experiment.

reagent 1

reagent 2

.....
.....
.....
.....
..... [4]

- 6 The bending of light when it travels from air into a liquid, or from a liquid into the air, is known as refraction.

For
Examiner's
Use

A student is trying to compare the refraction of light by salty water and by fresh water. He has placed a coin at the bottom of an empty bucket. A ruler is placed vertically a short distance from the bucket.

The student notes the position of his eye next to the ruler when he can just see the coin above the rim of the empty bucket. This is shown in Fig. 6.1.

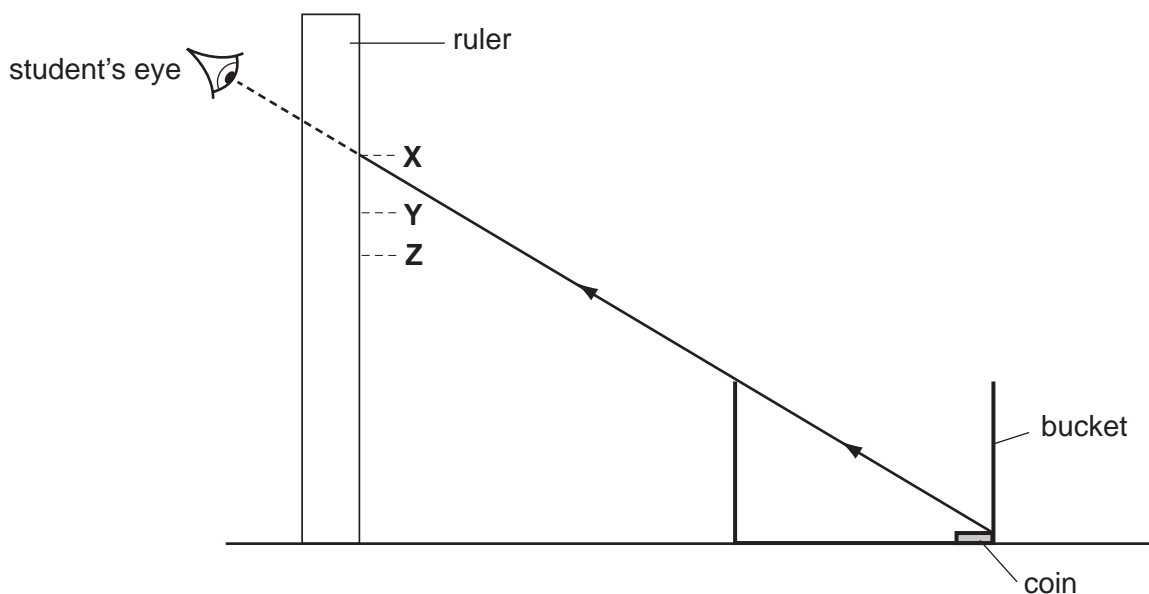

Fig. 6.1

- He records the position of his eye, point **X**, in Table 6.1.
- He fills the bucket with fresh water.
- He finds and records the new position of his eye when he can just see the coin, point **Y**.
- He empties the bucket and refills it with salty water.
- He finds and records point **Z** when he can just see the coin.

Fig. 6.2 shows a scale diagram of the experiment.

For
Examiner's
Use

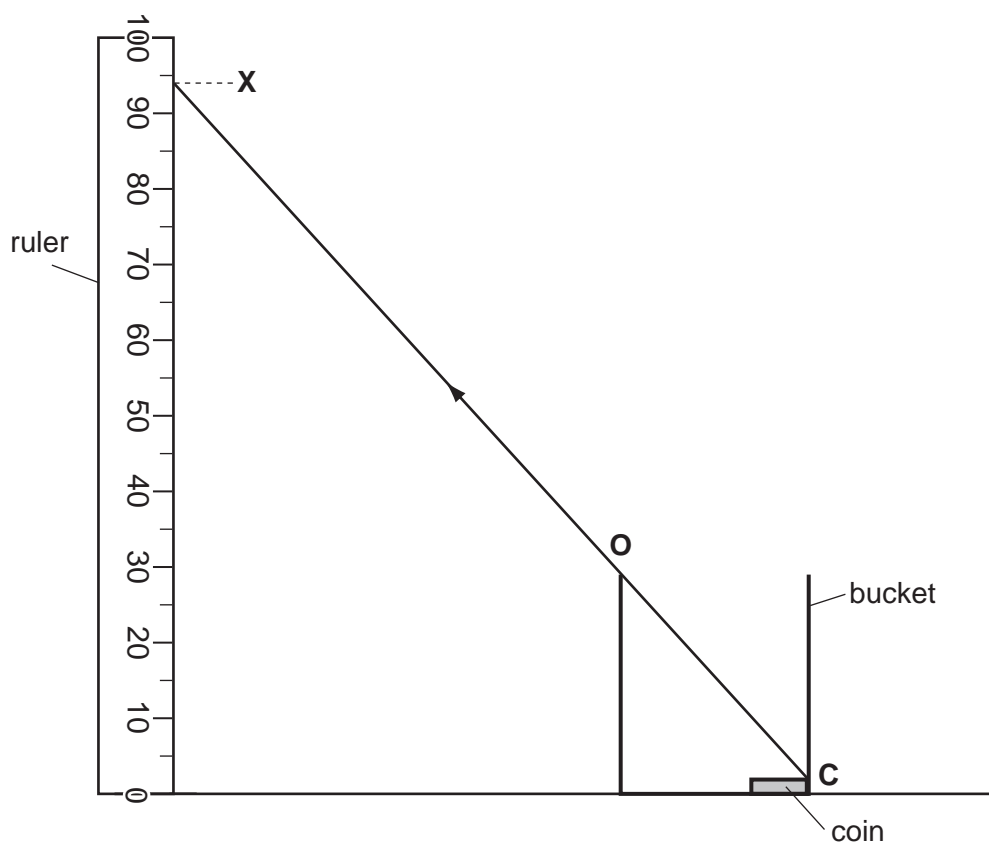

Fig. 6.2

The line **XC** shows a ray of light travelling from the coin to the student's eye. Point **O** is on this ray, just above the rim of the bucket.

- (a) On the ruler in Fig. 6.2, mark and label the points **Y** and **Z**. Use the data from Table 6.1. [2]

Table 6.1

contents of the bucket	point	position on ruler/cm
air	X	94
fresh water	Y	58
salty water	Z	51

- (b) On Fig. 6.2, draw the straight lines **YO** and **ZO**. See Fig. 6.1. [1]

(c) Measure and record, to the nearest millimetre, the length of the lines that you have drawn on Fig. 6.1, and the length of line **XO**.

(i) **YO** mm [1]

(ii) **ZO** mm [1]

(iii) **XO** mm [1]

(d) The refractive index of a liquid is a measure of the bending of light as it enters or leaves the liquid.

(i) Calculate the refractive index of fresh water using the formula below.

$$\text{refractive index} = \frac{\text{length of the line } \mathbf{XO} / \text{mm}}{\text{length of the line } \mathbf{YO} / \text{mm}}$$

refractive index of fresh water = [1]

(ii) Calculate the refractive index of salty water using the formula below.

$$\text{refractive index} = \frac{\text{length of the line } \mathbf{XO} / \text{mm}}{\text{length of the line } \mathbf{ZO} / \text{mm}}$$

refractive index of salty water = [1]

- (e) (i) A bird is trying to catch a fish that is swimming below the surface of a fresh water river. The bird and the fish are shown in Fig. 6.3.

For
Examiner's
Use

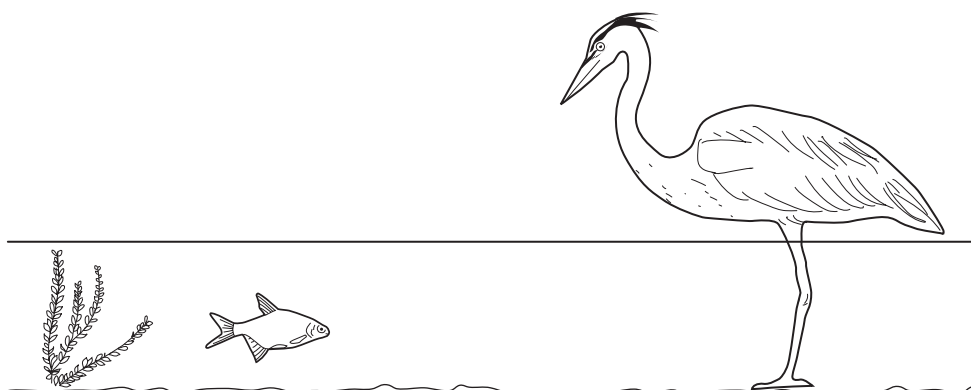

Fig. 6.3

Should the bird aim his beak above or below the position at which he sees the fish?

Explain your answer.

.....
.....
..... [1]

- (ii) How should the aim of the bird change if the fish is swimming in salty seawater instead of fresh water?

Explain your answer.

.....
.....
..... [1]

Permission to reproduce items where third-party owned material protected by copyright is included has been sought and cleared where possible. Every reasonable effort has been made by the publisher (UCLES) to trace copyright holders, but if any items requiring clearance have unwittingly been included, the publisher will be pleased to make amends at the earliest possible opportunity.

University of Cambridge International Examinations is part of the Cambridge Assessment Group. Cambridge Assessment is the brand name of University of Cambridge Local Examinations Syndicate (UCLES), which is itself a department of the University of Cambridge.