



UNIVERSITY OF CAMBRIDGE INTERNATIONAL EXAMINATIONS
International General Certificate of Secondary Education

CANDIDATE
NAME

CENTRE
NUMBER

--	--	--	--	--

CANDIDATE
NUMBER

--	--	--	--

* 6 4 4 5 7 1 2 8 6 1 *

CO-ORDINATED SCIENCES

0654/61

Paper 6 Alternative to Practical

October/November 2011

1 hour

Candidates answer on the Question paper

No Additional Materials are required.

READ THESE INSTRUCTIONS FIRST

Write your Centre number, candidate number and name on all the work you hand in.

Write in dark blue or black pen.

You may use a soft pencil for any diagrams, graphs, tables or rough working.

Do not use staples, paper clips, highlighters, glue or correction fluid.

DO NOT WRITE IN ANY BARCODES.

Answer **all** questions.

At the end of the examination, fasten all your work securely together.

The number of marks is given in brackets [] at the end of each question or part question.

For Examiner's Use	
1	
2	
3	
4	
5	
6	
Total	

This document consists of **17** printed pages and **3** blank pages.



- 1 (a) A student carried out an investigation into the effect of high temperature on *catalase* enzyme activity. *Catalase* is an enzyme found in many tissues which catalyses the decomposition of hydrogen peroxide to produce a gas.

- The student labelled four large test-tubes tubes **A**, **B**, **C** and **D** and drew a line 1 cm from the top of each test-tube.
- He placed 10 cm³ of hydrogen peroxide and a drop of detergent into each test-tube.
- He placed a 5g piece of **raw** liver into tubes **A**, **B** and **C**. This immediately caused a chemical reaction to occur and 'foam' was produced.
- He recorded the time it took for the foam to reach the pen line.

The stopclock readings are shown in Fig. 1.1 below.



Fig. 1.1

- (i) Using Fig. 1.1, record in Table 1.1 the times taken, **in seconds**, for the foam to reach the pen line of test-tubes **A**, **B** and **C**.

Table 1.1

liver type	raw			boiled
test-tube	A	B	C	D
time taken /s				N/R

[3]

- (ii) A glowing splint was placed into the 'foam'. The splint began to burn brightly again.
Name the gas that was produced by the decomposition of the hydrogen peroxide.

..... [1]

- (iii) Calculate the average time taken, in seconds, for the foam to reach the pen line for the reactions in tubes **A**, **B** and **C**.

For
Examiner's
Use

..... [1]

The experiment was repeated using test-tube **D** and a 5 g piece of liver that had been **boiled** for one minute. A few bubbles were seen in the mixture. This was recorded in Table 1.1 as N/R (No reaction).

- (iv) Compare the results for the raw and boiled liver.

Explain the reasons for the difference in results.

.....
.....
..... [2]

- (b) (i) Suggest a reason why a few bubbles were produced in test-tube **D**.

..... [1]

- (ii) Suggest which conditions should be kept constant in this experiment.

.....
.....
..... [2]

- 2 The teacher has asked a student to investigate the speed of thermal decomposition of three metal carbonates, **A**, **B** and **C**. Carbonate **C** contains the unknown metal **X**.

For
Examiner's
Use

Fig. 2.1 shows the apparatus she is using. The metal carbonate decomposes when it is heated. The gas given off turns the limewater milky.

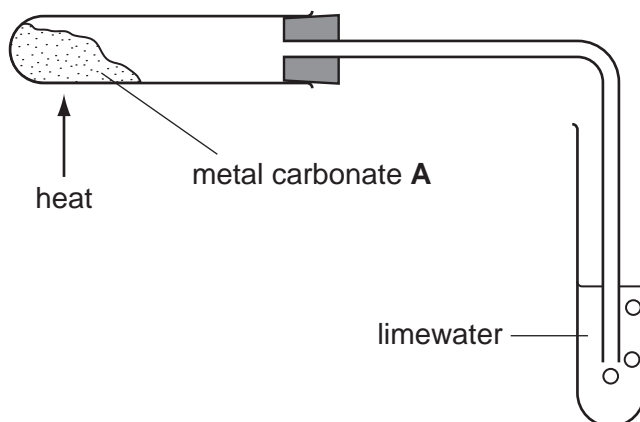

Fig. 2.1

- The student places about 1 cm depth of metal carbonate **A** in the hard-glass test-tube.
- She heats it and at the same time starts a stopclock.
- When the limewater turns milky, she stops the clock and records the result in Table 2.1.
- She records any colour change of the metal carbonate in Table 2.1.
- She repeats the experiment using metal carbonates **B** and **C**.

Table 2.1

metal carbonate	time taken for limewater to turn milky/s	colour change
A zinc carbonate		white at first, turns yellow and then becomes white on cooling
B magnesium carbonate		white at first, stays white
C carbonate of unknown metal X		green at first, turns black

- (a) Fig. 2.2 shows the stopclocks used for each test. The dials show the time taken by each carbonate to decompose and turn the limewater milky.

For
Examiner's
Use

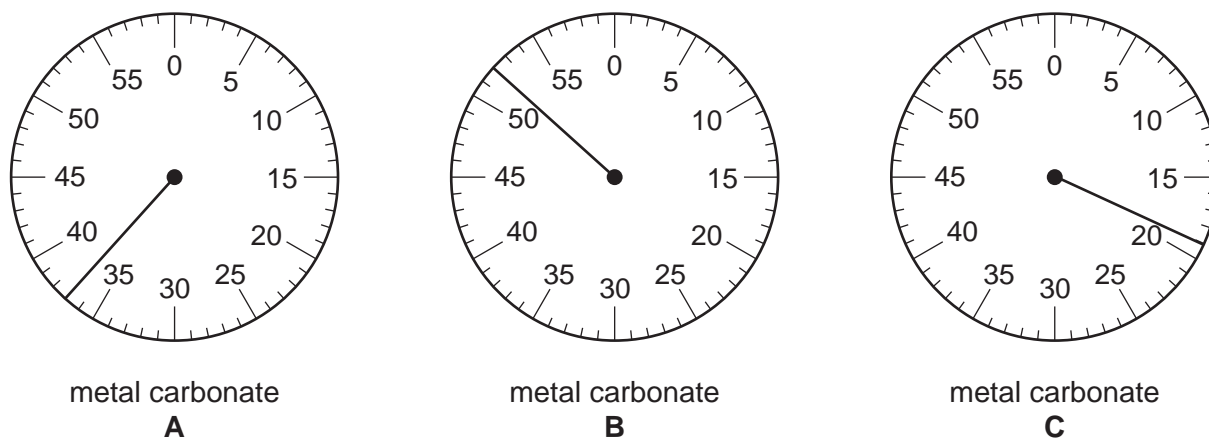

Fig. 2.2

- (i) Read the stopclock dials and record the times in Table 2.1. [3]
- (ii) Write the letters **A**, **B** or **C**, listing the metal carbonates in order of their speed of thermal decomposition.
- 1 (fastest)
- 2
- 3 (slowest) [1]
- (b) The student wants to find out the name of the unknown metal **X** found in metal carbonate **C**. When the heated test-tube has cooled, she places the black residue in a beaker and adds 20 cm³ of dilute sulfuric acid, stirring the mixture and then filtering it.
- (i) Draw a diagram to show how she filters the mixture.

[1]

The filtered solution is blue. She adds aqueous sodium hydroxide to 2cm^3 of the filtrate. There is a light blue precipitate.

For
Examiner's
Use

(ii) Suggest the name of the light blue precipitate.

..... [1]

(iii) Suggest the name of the black residue left after metal carbonate **C** was heated.

..... [1]

(c) The teacher gives the student a small piece of each of the three metals, zinc, magnesium and unknown metal **X**. She adds dilute hydrochloric acid to the metals in three separate test-tubes, shown in Fig. 2.3.

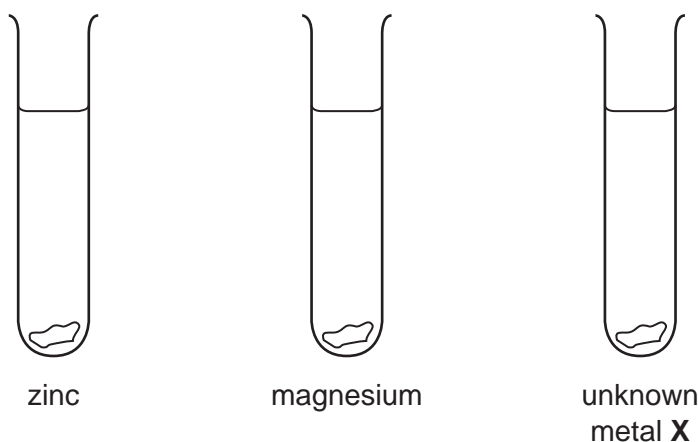

Fig. 2.3

On Fig. 2.3, draw the bubbles of gas, if any, that are produced in each test-tube. Your drawing should show clearly the different reactivity of each metal. [2]

(d) Compare your drawing in Fig. 2.3 with your answer to part (a)(ii). Can the different reactivity of the metals be used to predict the speed of thermal decomposition of the metal carbonates?

Explain your answer.

.....

 [1]

BLANK PAGE

Please turn over for Question 3.

- 3 A student is investigating how T , the time for one swing of a pendulum, is affected by the angle of swing.

For
Examiner's
Use

The pendulum is 30 cm long and suspended from a pin. The arrangement of apparatus is shown in Fig. 3.1.

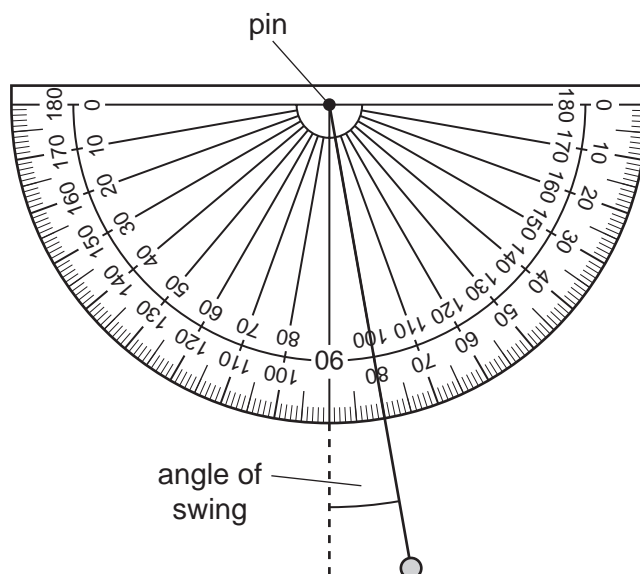

Fig. 3.1

- The student holds the pendulum so that the angle of swing is 10° , as in Fig. 3.1.
- He releases the pendulum and starts a stopclock.
- He allows the pendulum to swing 10 times.
- He records the time for 10 complete swings in Table 3.1.
- He repeats the experiment using different angles of swing.

Table 3.1

experiment	1	2	3	4	5	6	7	8
angle of swing/degrees	10	25	35	40				85
time for 10 swings/s	11.4	11.2	11.6	11.5				11.3
time, T for 1 swing/s								

- (a) (i) Fig. 3.2 shows the angle of swing and the digital stopclock for three more experiments.

For
Examiner's
Use

Read the angle of swing and the time for each angle of swing. Record the results in Table.3.1.

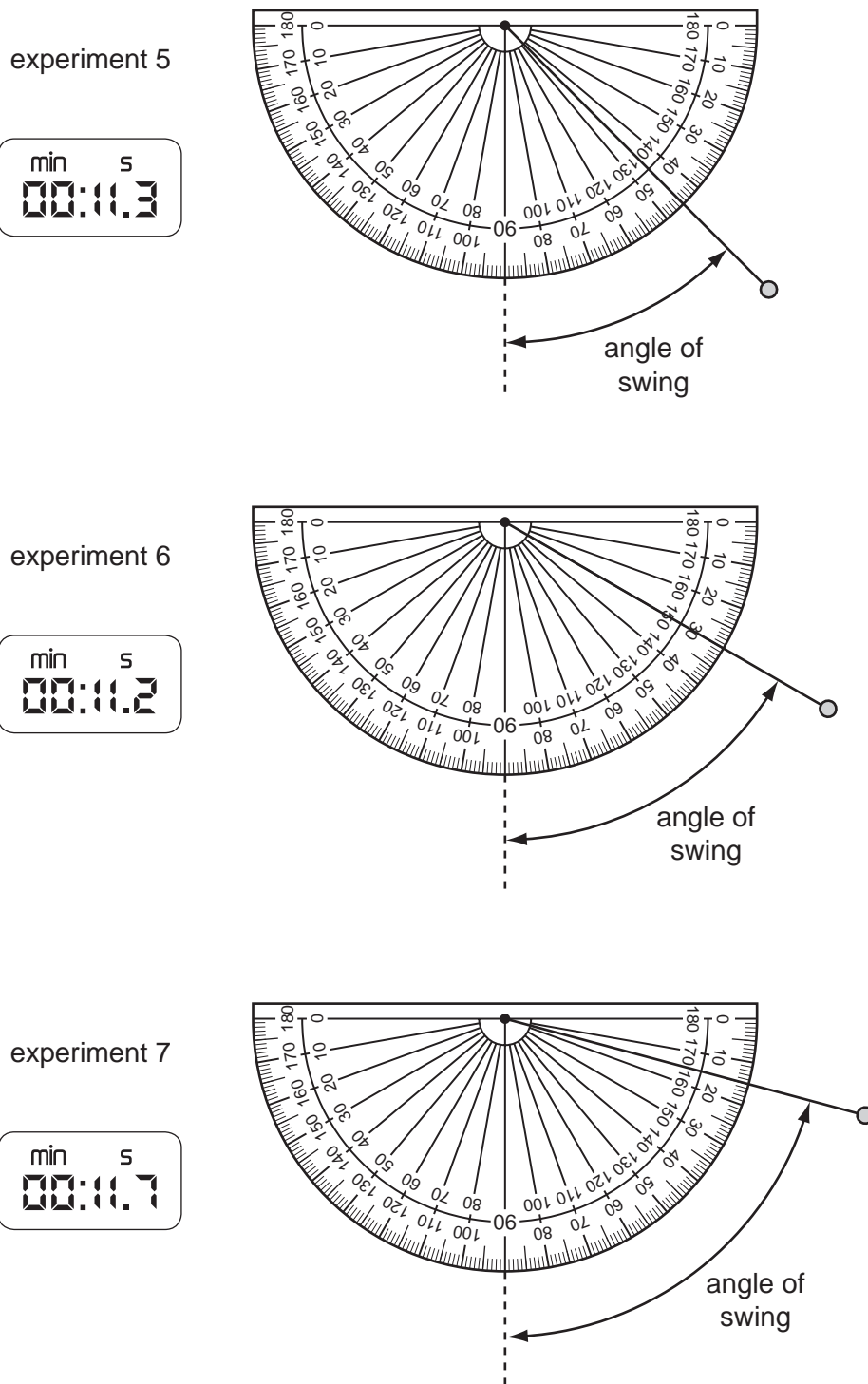

Fig. 3.2

[3]

- (ii) Complete Table 3.1 by finding the time, T , for one swing of the pendulum for each experiment. [1]

- (iii) Use the results for **T** in Table 3.1 to find the average time, **T_{av}**, for one swing of the pendulum for all experiments.

For
Examiner's
Use

T_{av} = s [1]

- (b) Do the results show that **T**, the time for one swing, is affected by the angle of swing?

Explain your answer.

.....
..... [1]

- (c) Explain how the student can make the results of his experiment more reliable.

.....
.....
..... [1]

- (d) The student is using a pendulum that is 30 cm long. Convert this value from centimetres to metres.

length of pendulum, **l** = m [1]

- (e) Use the value of **l** from part (d), **T_{av}** from part (a)(iii) and the formula below to calculate **g**, the acceleration due to gravity.

$$g = \frac{39.5 \times l}{(T_{av})^2}$$

g = m/s² [2]

Please turn over for Question 4.

- 4 (a) A student was given a solution and was told that it contained the enzyme amylase. Amylase is found in saliva. It catalyses the breakdown of starch into sugar.

The student wanted to confirm that the solution contained amylase by testing whether it could break down starch solution.

- He put some starch solution into test-tubes **A** and **B**. He added amylase solution to tube **A**. He added an equal volume of water to test-tube **B** as a control.
- After waiting for 10 minutes he added a few drops of iodine solution to each test-tube.
- The results showed that the starch had been completely broken down in test-tube **A** but had not broken down in test-tube **B**.

Describe the colours of the solutions after testing with iodine.

test-tube **A**

test-tube **B** [2]

- (b) The student believed that the activity of amylase is affected by the pH of solution. He did another experiment to confirm this as follows.

- He prepared starch solutions of 5 different pH values.
- He added amylase solution to the test-tube of pH 4.
- He started the timer.
- After 15 seconds he used a glass rod to remove a small sample of the test solution. He tested this with iodine.
- He used the iodine test to see if starch was still present. If starch was present he repeated the test after a further 15 seconds.
- He continued to test the solution every 15 seconds until the test showed that no starch remained. He entered the time taken for the starch to disappear in Table 4.1.
- He then repeated the procedure for the remaining pH values.

- (i) Read the stopclocks in Fig. 4.1 and enter the missing times, in seconds, in Table 4.1.

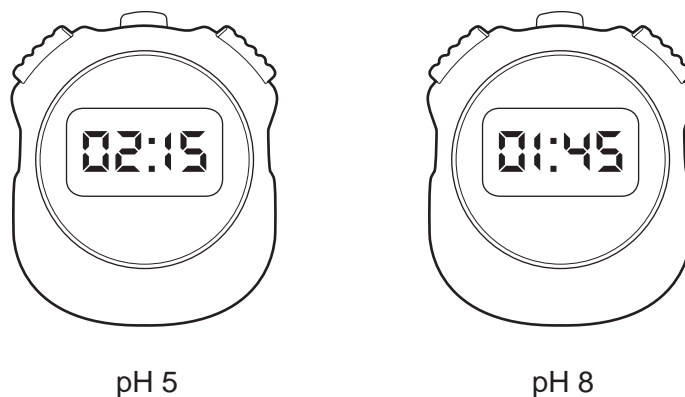

Fig. 4.1

Table 4.1

pH	time for starch to disappear / s
4	195
5	
6	90
7	90
8	

For
Examiner's
Use

[2]

(ii) Plot a graph of time against pH. Draw a smooth curve through your points.

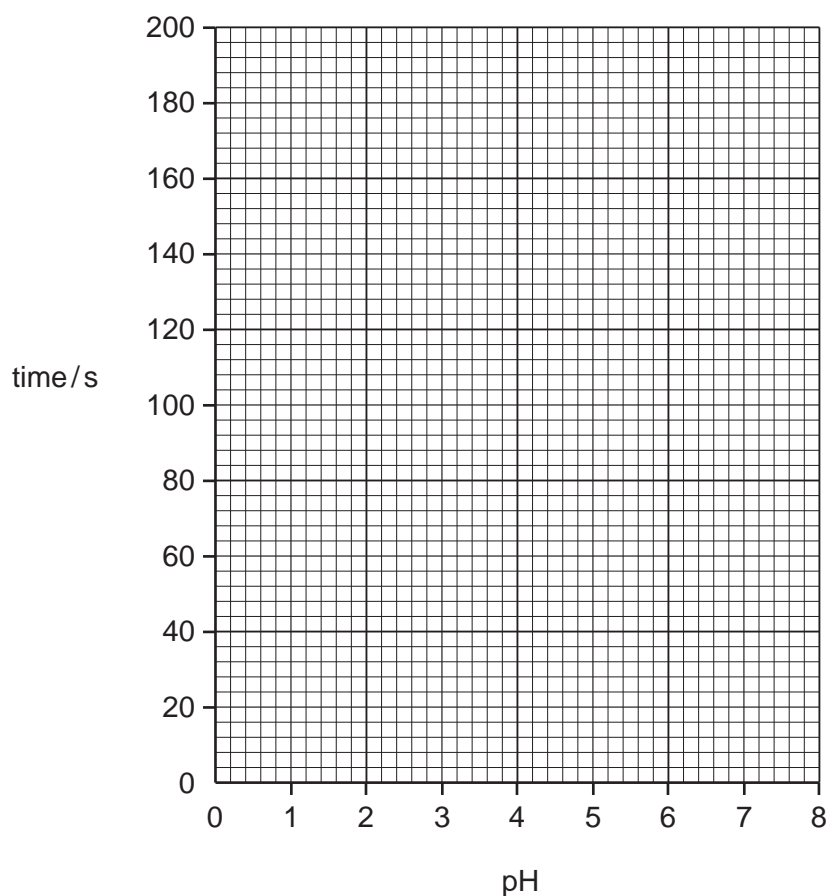

[2]

(iii) Over which pH range is the activity of the amylase greatest?

pH range = [1]

- (c) (i) The student knew that the experiment could be improved to obtain a more accurate value of pH for the greatest activity.

List **two** improvements he could make to the experiment.

1

2 [2]

- (ii) Choose **one** of the improvements you have suggested. Explain why it would improve the accuracy of pH of greatest activity.

.....

.....

..... [1]

Please turn over for Question 5.

- 5 The teacher gives her students five gas-jars, each containing a different gas. The gas-jars are labelled **A, B, C, D** and **E**. She also gives them a key to use to determine the name of each gas. The key is shown in Fig. 5.1.

For
Examiner's
Use

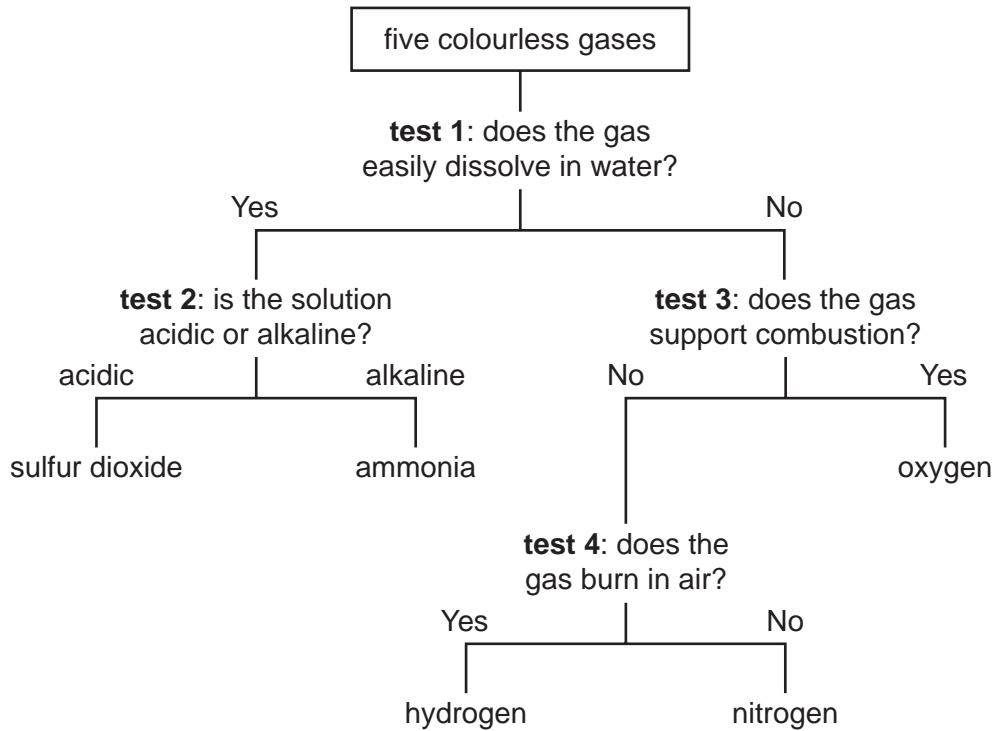

Fig. 5.1

Fig. 5.2 shows a gas-jar of gas that has been inverted and placed in a bowl of water with its lid still on.

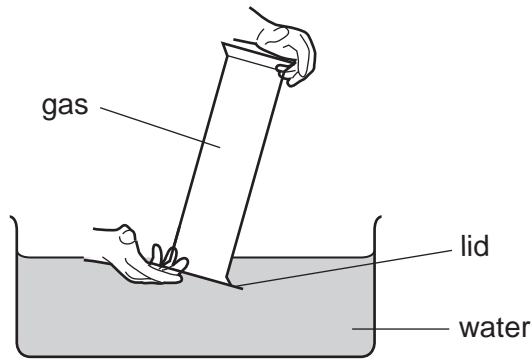

Fig. 5.2

One student is testing one of the gases to see if it will dissolve in water. He places the mouth of the gas-jar in the water as shown in Fig. 5.2. He then removes the lid of the gas-jar.

- (a) (i) Describe what he observes if the gas **does** dissolve in the water in the bowl.

..... [1]

- (ii) Explain why this happens.

.....
 [1]

(b) Assuming that the gas in the gas-jar in Fig. 5.2 has dissolved in the water, explain how you can carry out **test 2**, shown in Fig. 5.1, on the solution in the bowl. Give the results for an acidic gas and an alkaline gas.

test 2 [1]
 [1]
 result for acid gas [1]
 result for alkaline gas [1]

(c) Explain how you would carry out **test 3**, shown in Fig. 5.1, on a gas-jar of gas. Describe the result for oxygen.

test 3 [1]
 [1]
 result for oxygen [1]

(d) Explain how you would carry out **test 4**, shown in Fig. 5.1, on a gas-jar of gas. Describe the result for hydrogen.

test 4 [1]
 [1]
 result for hydrogen [1]

The conclusions that the students made, after carrying out all of the tests, are shown in Table 5.1.

Table 5.1

gas A	gas B	gas C	gas D	gas E
oxygen	sulfur dioxide	nitrogen	ammonia	hydrogen

(e) Suggest the names of **two** of the gases listed in Table 5.1 that will react together, when mixed at room temperature and pressure, without using either a catalyst or a flame.

..... and [1]

- 6 A student is comparing the electrical resistances of two pieces of resistance wire, **X** and **Y**. The wires are made from the same alloy but are different in length and thickness.

For
Examiner's
Use

The pieces of wire are shown in Fig. 6.1.

wire **X**



wire **Y**



Fig. 6.1

- (a) Measure the lengths of wire **X** and wire **Y** in centimetres to the nearest millimetre. Record the lengths in Table 6.1.

Table 6.1

wire	X	Y
length/cm		
thickness/millimetres	0.2	0.9

[2]

The student uses the circuit shown in Fig. 6.2 to find the resistance of the wires.

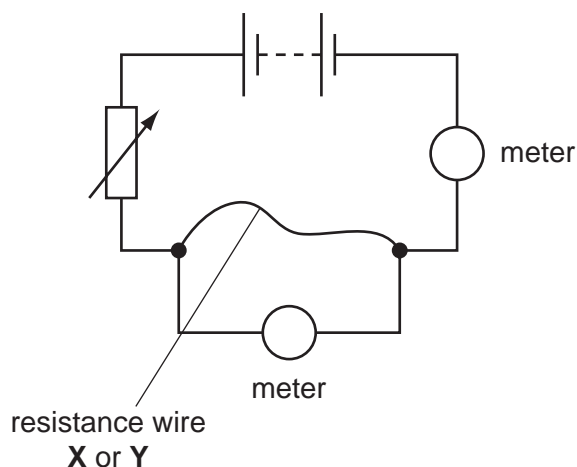

Fig.6.2

- (b) (i) Complete the diagram in Fig. 6.2 by writing the letters **A** and **V** to show the ammeter and voltmeter in the correct places. [1]

- (ii) Fig. 6.3 shows the voltmeter and ammeter readings when one of the wires is connected in the circuit.

Read the meters and record the readings in column 1 of Table 6.2.

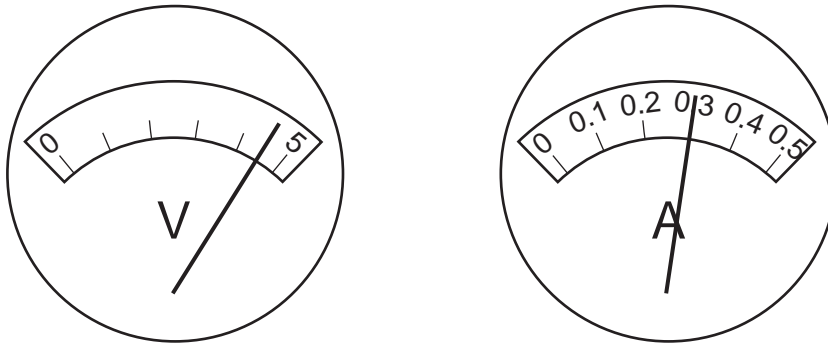

Fig. 6.3

Table 6.2

	column 1	column 2
current/ amps		2.5
voltage/ volts		0.5
resistance/ ohms		0.2

[2]

- (iii) Use the data in column 1 of Table 6.2 to calculate the resistance of this wire. Record the resistance in Table 6.2.

[2]

- (c) The student has forgotten which wire he used to record the data in each column of Table 6.2.

- (i) Decide which wire, **X** or **Y**, produced the results shown in column 1, and which wire produced the results shown in column 2.

Complete the sentences.

Column 1 shows the data for wire

Column 2 shows the data for wire

[1]

- (ii) Explain your choice in (c)(i) by stating how the lengths and thicknesses of the two wires affect their electrical resistance.

.....

.....

.....

..... [2]

*For
Examiner's
Use*

Permission to reproduce items where third-party owned material protected by copyright is included has been sought and cleared where possible. Every reasonable effort has been made by the publisher (UCLES) to trace copyright holders, but if any items requiring clearance have unwittingly been included, the publisher will be pleased to make amends at the earliest possible opportunity.

University of Cambridge International Examinations is part of the Cambridge Assessment Group. Cambridge Assessment is the brand name of University of Cambridge Local Examinations Syndicate (UCLES), which is itself a department of the University of Cambridge.