



UNIVERSITY OF CAMBRIDGE INTERNATIONAL EXAMINATIONS
International General Certificate of Secondary Education

CANDIDATE
NAME

CENTRE
NUMBER

--	--	--	--	--

CANDIDATE
NUMBER

--	--	--	--	--

* 8 8 6 1 0 1 6 8 2 3 *

CO-ORDINATED SCIENCES

0654/51

Paper 5 Practical Test

October/November 2011

2 hours

Candidates answer on the Question Paper.

Additional Materials: As listed in Instructions to Supervisors

READ THESE INSTRUCTIONS FIRST

Write your Centre number, candidate number and name on all the work you hand in.

Write in dark blue or black pen.

You may use a pencil for any diagrams, graphs or rough working.

Do not use staples, paper clips, highlighters, glue or correction fluid.

DO NOT WRITE IN ANY BARCODES.

Answer **all** questions.

Chemistry practical notes for this paper are printed on page 12.

At the end of the examination, fasten all your work securely together.

The number of marks is given in brackets [] at the end of each question or part question.

For Examiner's Use	
1	
2	
3	
Total	

This document consists of **10** printed pages and **2** blank pages.



1 (a) You are going to compare the activity of the enzyme *catalase* in raw and boiled yeast. *Catalase* accelerates the decomposition of hydrogen peroxide and is found in most living cells.

- Label 5 large test-tubes **A**, **B**, **C**, **D**, and **E**. Use the permanent marker to draw a line on each tube 1 cm below the top.
- Place the large test-tubes into a rack and measure out 20 cm³ of hydrogen peroxide solution into each tube.
- (i)
 - Place a few drops of the **fresh** yeast suspension into the hydrogen peroxide in test-tube **A**.
 - Place a glowing splint into test-tube **A**, just above the hydrogen peroxide and yeast mixture.
 - Record your observation and state the name of the gas that has been produced.

observation

.....

name of gas produced [2]

- (ii)
 - Add two drops of detergent to the hydrogen peroxide in test-tubes **B**, **C** and **D**.
 - Measure out 5 cm³ of **fresh** yeast suspension into a syringe or dropping pipette. Place the yeast into the hydrogen peroxide in test-tube **B**.
 - Start the stop-clock as soon as the yeast makes contact with the hydrogen peroxide.
 - In Table 1.1, record the time taken **in seconds** for the foam to reach the pen line.
 - Repeat for tubes **C** and **D**. [2]

Table 1.1

yeast type	fresh			boiled
tube	B	C	D	E
time taken / s				

- (iii) Calculate the average time, **in seconds**, for the fresh yeast (tubes **B**, **C** and **D**).

[1]

- (b) (i) • Measure out 5 cm³ of **boiled** yeast into a syringe or dropping pipette.
- Place the yeast suspension into the hydrogen peroxide in large test-tube **E**.
- Start the stop-clock and record, in Table 1.1, the time taken, in seconds, for the foam (if any) to reach the pen line on the test-tube.
- If no foam is produced, or the foam has not reached the line after two minutes, record 'No reaction' in Table 1.1. [1]

(ii) Compare the results for the fresh and boiled yeast.

Explain the difference in the activity of the enzyme *catalase* in the fresh and boiled yeast.

.....

.....

.....

..... [2]

(c) (i) Are the results for tubes **B**, **C** and **D** reliable?

Explain your answer.

.....

..... [1]

(ii) Suggest **two** possible sources of error in this experiment.

1

.....

2

..... [2]

(d) Design an experiment to investigate the effect of changing temperature on the activity of the enzyme *catalase*.

.....

.....

.....

.....

.....

..... [4]

- 2 You are going to investigate the thermal decomposition of three metal carbonates, comparing the thermal decomposition of each carbonate with the reactivity of its metal with acid. Finally, you will identify an unknown metal.

For
Examiner's
Use

- (a) (i) Place compound **A**, which is a metal carbonate, in a clean hard glass test-tube. Place about 3 cm³ of limewater in a second test-tube. Connect the bung of the delivery tube to the test-tube containing **A** and place the delivery tube into the limewater as shown in Fig. 2.1.

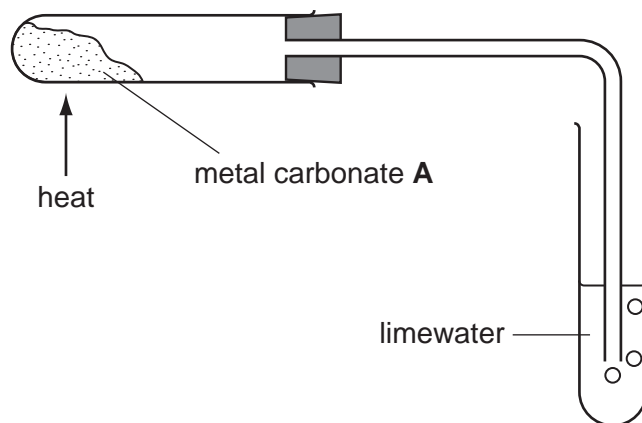

Fig. 2.1

- (ii) Heat the tube containing compound **A** with a hot flame, starting the clock as you do so. When the limewater becomes milky, stop the clock and **immediately** remove the delivery tube from the limewater.

Record the time taken, in seconds, for the limewater to become milky, as well as any colour change to the carbonate, in Table 2.1.

Table 2.1

compound	name and formula	time / s	colour change
A	zinc carbonate, ZnCO ₃		
B	magnesium carbonate, MgCO ₃		
C	unknown metal carbonate, XCO ₃		

[1]

- (iii) Repeat (a)(i) and (a)(ii) with the compounds **B** and **C**, using fresh limewater each time. Record the results in Table 2.1. [2]

Keep the test-tube containing the result of heating compound **C** for part (c).

- (iv) List the metal carbonates in order of their speed of turning limewater milky (speed of thermal decomposition).

1 (fastest)

2

3 (slowest)

[1]

- (v) Name the gas produced by the thermal decomposition of a metal carbonate.

name

[1]

- (b) (i) Place a piece of zinc into a clean test-tube. Place a piece of magnesium into a second test-tube and a piece of unknown metal **X** into a third test-tube. Add about 3 cm³ of dilute sulfuric acid to each test-tube.

Record your observations in Table 2.2.

Table 2.2

metal	observations
zinc	
magnesium	
unknown metal X	

[3]

- (ii) List the metals tested in (b)(i) in order of reactivity.

1 (most reactive)

2

3 (least reactive)

[1]

- (iii) Compare your answers to (a)(iv) and (b)(ii).

Can the order of reactivity of metals be used to predict the order of speed of thermal decomposition of metal carbonates?

Explain your answer.

.....

..... [1]

(c) Empty the contents of the test-tube in which compound **C** was heated into a beaker. Add about 10 cm³ of dilute sulfuric acid and stir well. Filter the resulting mixture into **two** clean test-tubes. Keep the filtrate for parts (c)(i) and (c)(ii).

(i) Carefully add dilute sodium hydroxide to the filtrate in one of the test-tubes until there is no further change.

Record your observation.

.....
..... [1]

(ii) To the other test-tube containing the filtrate, add a piece of zinc.

Record your observations.

.....
.....
..... [2]

(iii) Identify metal **X** and state **two** pieces of evidence to support this.

metal **X** is

evidence 1

.....

evidence 2

..... [2]

Please turn over for Question 3.

- 3 You are going to investigate how the angle of swing, θ , affects the time period for one oscillation, T , of a simple pendulum. You will also use your results to calculate the acceleration due to gravity, g .

For
Examiner's
Use

- (a) Set up your pendulum as in Fig. 3.1, using the apparatus provided, such that the length, l , is 30 cm.

Clamp the cork and secure the protractor card to the cork with the short pin. Attach the protractor to the card as shown, using the long pin. Suspend the pendulum from the long pin.

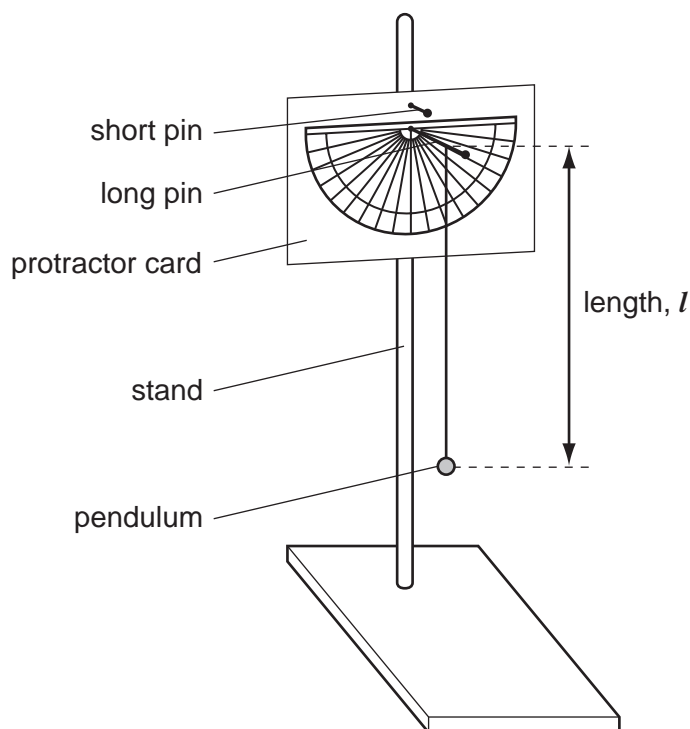

Fig. 3.1

Displace the pendulum by $\theta = 10^\circ$ as shown in Fig. 3.2.

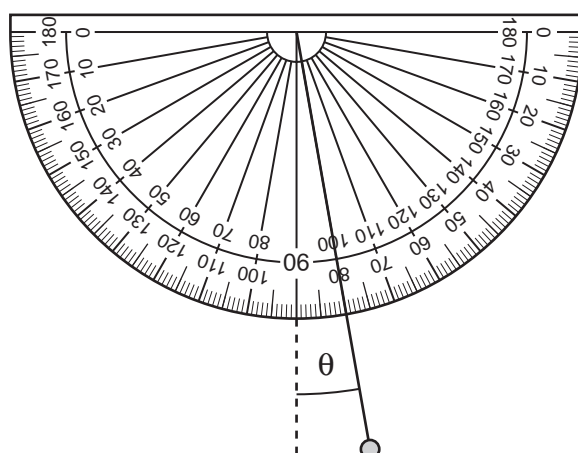

Fig. 3.2

- (i) Release the pendulum and start the clock at the same time. Stop the clock when the pendulum has completed ten oscillations. (One oscillation is swinging away from and back to the release point). Record the time in Table 3.1 to 0.1 second.

- (ii) Repeat the experiment for $\theta = 10^\circ$ a further four times and record the results in Table 3.1.
- (iii) Now carry out the experiment five times each for angles of swing $\theta = 20^\circ$ and $\theta = 30^\circ$ recording all results in Table 3.1.

For
Examiner's
Use

Table 3.1

	time for 10 oscillations /s		
	$\theta = 10^\circ$	$\theta = 20^\circ$	$\theta = 30^\circ$
1			
2			
3			
4			
5			
average for 10 oscillations /s			
period, T/s			

[5]

- (b) (i) Calculate the average time for 10 oscillations for each angle of swing, θ . Record your averages in Table 3.1. [1]
- (ii) Calculate the period, T (the time for one oscillation), from the average for 10 oscillations for each angle of swing, θ . Record values of T in Table 3.1. [1]
- (iii) Describe the relationship between the period, T , and the angle of swing, θ .

.....
..... [1]

(iv) Explain how you can tell that the period, **T**, is **not** proportional to the angle of swing, **θ**.

.....
.....
..... [1]

(c) Use the period **T** for **θ** = 10° in Table 3.1 to calculate the acceleration due to gravity, **g**, using the formula below. You must include units in your answer. (the length of the pendulum, **l**, must be in metres).

$$g = \frac{39.5 \times l}{T^2}$$

g = units [3]

(d) (i) Explain why you timed 10 oscillations in your experiments rather than timing just one oscillation to obtain the period, **T**, directly.

.....
..... [1]

(ii) Suggest **one** possible source of error in this experiment to find a value for **g**.

.....
..... [1]

(iii) For the source of error you have chosen in (d)(ii), describe how this error could be reduced.

.....
..... [1]

CHEMISTRY PRACTICAL NOTES

Test for anions

<i>anion</i>	<i>test</i>	<i>test result</i>
carbonate (CO_3^{2-})	add dilute acid	effervescence, carbon dioxide produced
chloride (Cl^-) [in solution]	acidify with dilute nitric acid, then add aqueous silver nitrate	white ppt.
nitrate (NO_3^-) [in solution]	add aqueous sodium hydroxide then aluminium foil; warm carefully	ammonia produced
sulfate (SO_4^{2-}) [in solution]	acidify then add aqueous barium chloride <i>or</i> aqueous barium nitrate	white ppt.

Test for aqueous cations

<i>cation</i>	<i>effect of aqueous sodium hydroxide</i>	<i>effect of aqueous ammonia</i>
ammonium (NH_4^+)	ammonia produced on warming	-
copper(II) (Cu^{2+})	light blue ppt., insoluble in excess	light blue ppt., soluble in excess giving a dark blue solution
iron(II) (Fe^{2+})	green ppt., insoluble in excess	green ppt., insoluble in excess
iron(III) (Fe^{3+})	red-brown ppt., insoluble in excess	red-brown ppt., insoluble in excess
zinc (Zn^{2+})	white ppt., soluble in excess giving a colourless solution	white ppt., soluble in excess giving a colourless solution

Test for gases

<i>gas</i>	<i>test and test results</i>
ammonia (NH_3)	turns damp red litmus paper blue
carbon dioxide (CO_2)	turns limewater milky
chlorine (Cl_2)	bleaches damp litmus paper
hydrogen (H_2)	"pops" with a lighted splint
oxygen (O_2)	relights a glowing splint

Permission to reproduce items where third-party owned material protected by copyright is included has been sought and cleared where possible. Every reasonable effort has been made by the publisher (UCLES) to trace copyright holders, but if any items requiring clearance have unwittingly been included, the publisher will be pleased to make amends at the earliest possible opportunity.

University of Cambridge International Examinations is part of the Cambridge Assessment Group. Cambridge Assessment is the brand name of University of Cambridge Local Examinations Syndicate (UCLES), which is itself a department of the University of Cambridge.