



UNIVERSITY OF CAMBRIDGE INTERNATIONAL EXAMINATIONS
International General Certificate of Secondary Education

CO-ORDINATED SCIENCES

0654/11

Paper 1 Multiple Choice

October/November 2010

45 minutes

Additional Materials: Multiple Choice Answer Sheet
Soft clean eraser
Soft pencil (type B or HB is recommended)

* 5 8 3 1 7 4 0 6 9 6 *

READ THESE INSTRUCTIONS FIRST

Write in soft pencil.

Do not use staples, paper clips, highlighters, glue or correction fluid.

Write your name, Centre number and candidate number on the Answer Sheet in the spaces provided unless this has been done for you.

There are **forty** questions on this paper. Answer **all** questions. For each question there are four possible answers **A, B, C** and **D**.

Choose the **one** you consider correct and record your choice in **soft pencil** on the separate Answer Sheet.

Read the instructions on the Answer Sheet very carefully.

Each correct answer will score one mark. A mark will not be deducted for a wrong answer.

Any rough working should be done in this booklet.

A copy of the Periodic Table is printed on page **20**.

This document consists of **17** printed pages and **3** blank pages.



1 Which features are found in mammals but **not** in other vertebrates?

- A claws and hair
- B claws and lungs
- C hair and milk
- D lungs and milk

2 Which cells produce starch in their cytoplasm?

- A all animal cells
- B all plant cells
- C some animal cells
- D some plant cells

3 The diagram shows a leaf, still attached to a plant, with both green and white regions that have been partly covered with black paper.

The leaf is left in bright light for six hours and then tested for starch.

Which area of the leaf turns blue-black after the starch test?

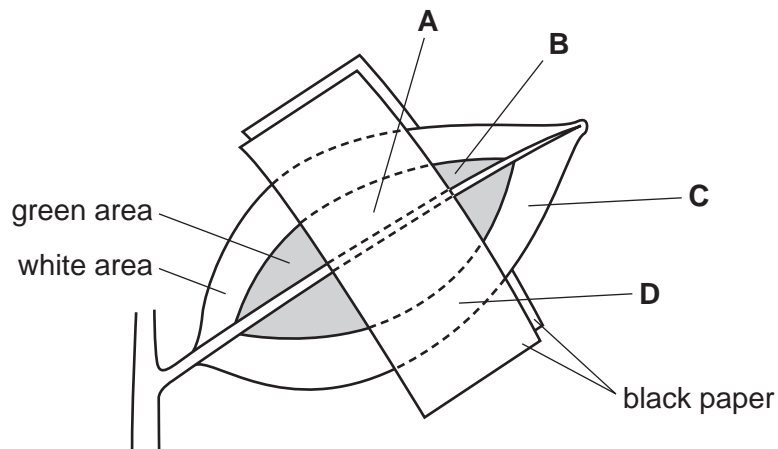

4 The diagram shows part of the digestive system.

Where does lipase digest fat?

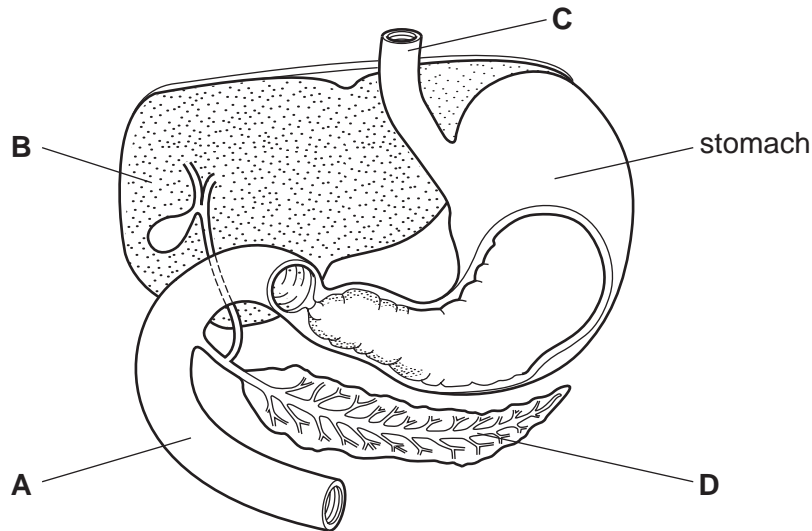

5 How do bacteria cause tooth decay?

- A They release acids that dissolve enamel.
- B They release alkalis that dissolve enamel.
- C They release enzymes that digest enamel.
- D They release ethanol that digests enamel.

6 What happens during anaerobic respiration in muscle cells?

- A carbon dioxide is released
- B energy is released
- C lactic acid is oxidised
- D water is released

7 Which row is correct for the blood in veins?

	direction of flow	oxygen content
A	away from heart	always high
B	away from heart	high or low
C	towards heart	always low
D	towards heart	high or low

- 8 Which internal conditions in a human being are maintained at a more or less constant level as the result of homeostasis?

	blood glucose	blood insulin	body temperature
A	✓	✓	✓
B	✓	✓	x
C	✓	x	✓
D	x	✓	✓

- 9 The diagram shows two stages in an attempt to kill a fly.

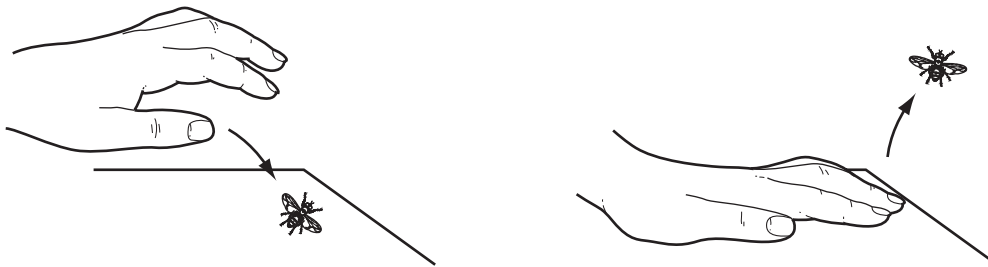

What else does the diagram show?

- A** The fly converts impulses to stimuli.
B The fly responds to a stimulus.
C The hand produces impulses.
D The hand is a receptor.
- 10 The diagram shows a wind-dispersed, single-seeded fruit.

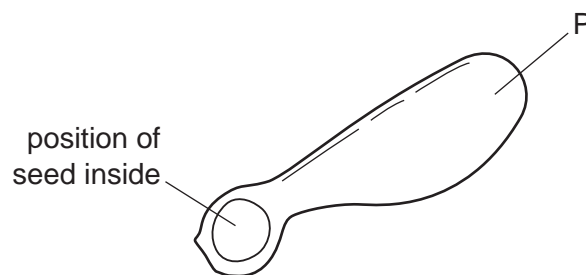

Structure P is an extension of which part?

- A** cotyledon
B leaf
C ovary wall
D testa

11 The diagram shows a developing fetus.

Where does the fetal blood become oxygenated?

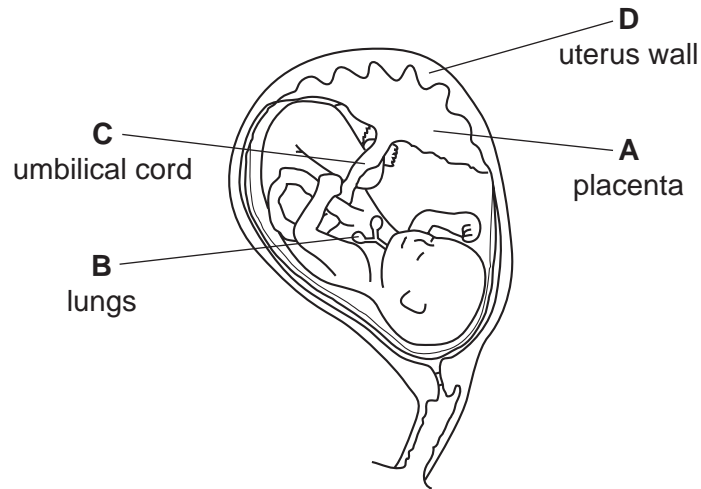

12 The alleles for a particular character are H and h.

Which term describes an organism whose genotype is Hh?

- A heterozygote
- B homozygote
- C phenotype
- D recessive

13 The diagram shows part of the carbon cycle which includes a food chain.

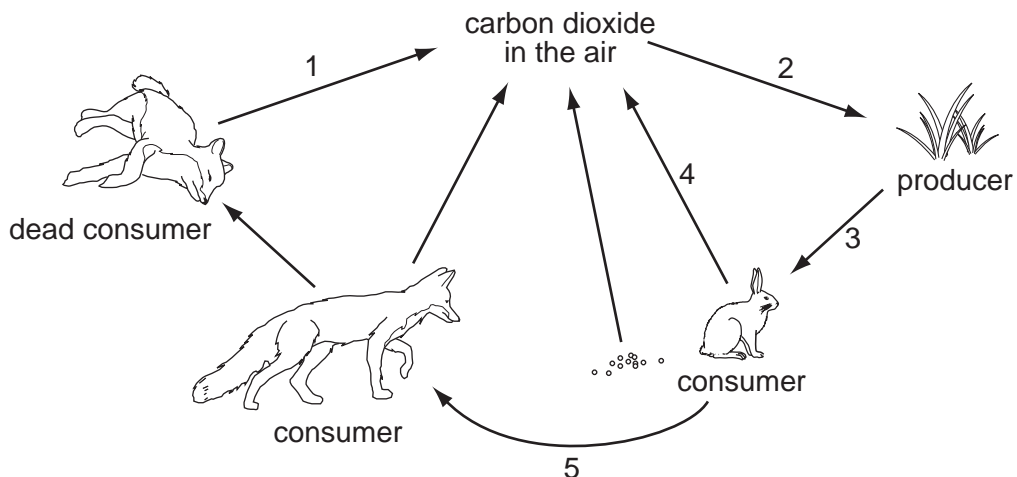

Which arrows are part of the food chain?

- A 1 and 2
- B 2 and 3
- C 3 and 5
- D 4 and 5

14 The three states of matter are represented by diagrams X, Y and Z.

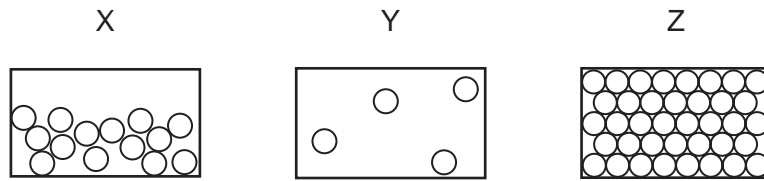

Which change occurs during condensation?

- A** X to Y **B** X to Z **C** Y to X **D** Z to X

15 The diagram shows a circuit.

Solid X makes the lamp light.

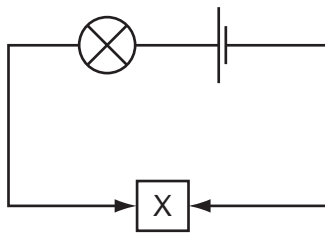

What is solid X?

- A** rubber
B silicon(IV) oxide
C sulfur
D zinc

16 Which two elements are present in the compounds found in petroleum?

- A** carbon and nitrogen
B carbon and oxygen
C hydrogen and carbon
D hydrogen and oxygen

17 Which molecules join into long chains to make proteins?

- A** amino acids
B ethene
C glucose
D starch

18 Which material is made from silicon(IV) oxide combined with metal oxides?

- A brass
- B glass
- C polythene
- D steel

19 Carbon is used in the extraction of some metals from their ores because

- 1 carbon forms strong alloys with metals,
- 2 carbon reacts with oxygen in the ore.

Which of these statements are correct?

- A 1 only
- B 2 only
- C both 1 and 2
- D neither 1 nor 2

20 Sodium chloride solution is electrolysed and a gas is collected at each electrode.

One gas decolourises moist litmus paper, the other gas burns with a pop.

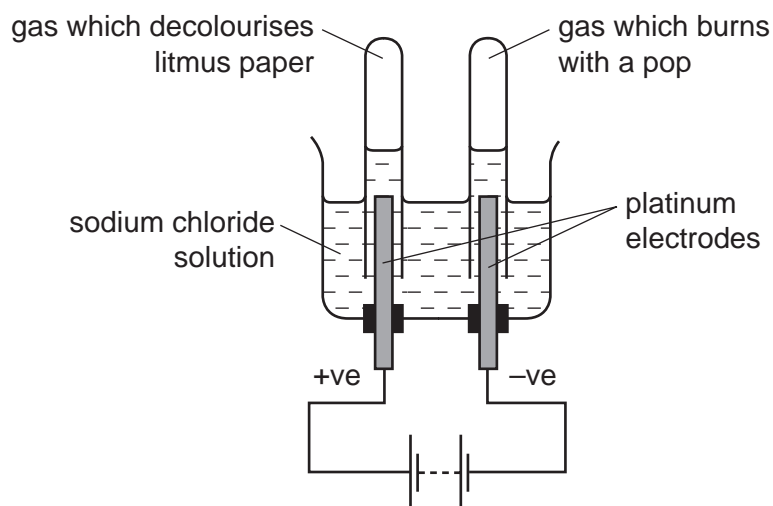

Which statement is correct?

- A Chlorine gas is collected at the anode.
- B Hydrogen gas is collected at the anode.
- C Oxygen gas is collected at the cathode.
- D The cathode is the positive electrode.

21 Rocks can be weathered by natural changes.

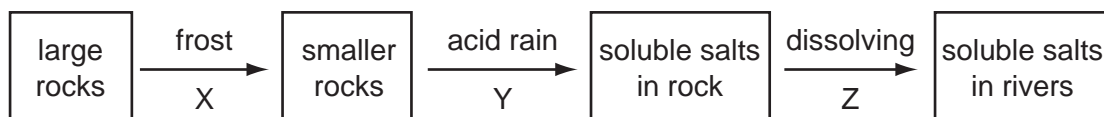

Which row correctly describes the type of change?

	X	Y	Z
A	chemical	chemical	chemical
B	chemical	physical	chemical
C	physical	chemical	physical
D	physical	physical	physical

22 Compound X is heated gently with aluminium powder and sodium hydroxide solution.

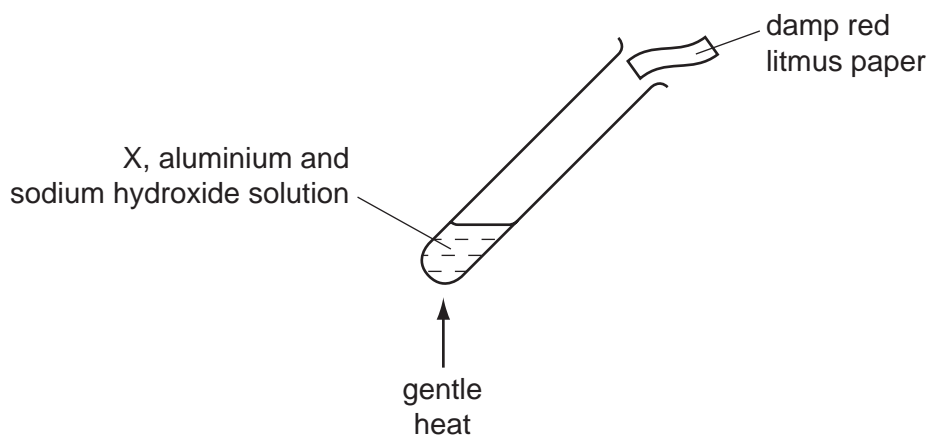

The damp red litmus paper turns blue.

What does X contain?

- A** carbonate
- B** chloride
- C** nitrate
- D** sulfate

23 A student uses the apparatus shown to find out how many different pigments are in leaves.

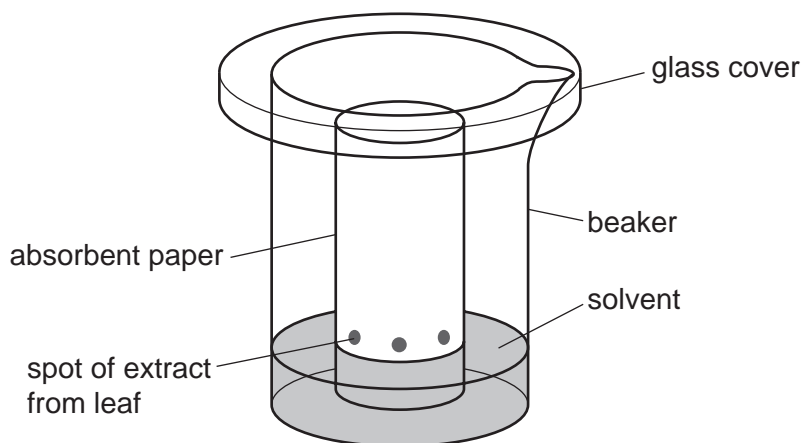

What is this separation method called?

- A chromatography
- B distillation
- C evaporation
- D filtration

24 Paint contains particles of solid finely dispersed in a liquid.

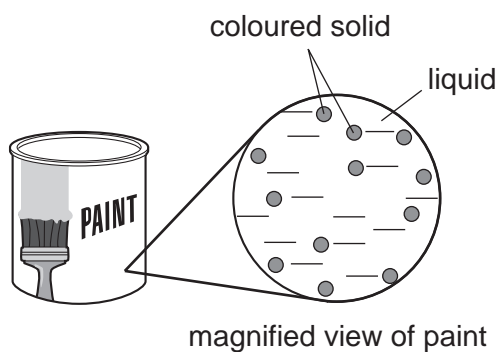

Which term correctly describes paint?

- A emulsion
- B gel
- C sol
- D solution

25 Waste material buried underground can decay to form gas X which can be used as a fuel.

X burns to form an oxide Y and water.

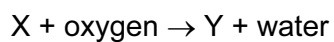

What is Y?

- A carbon dioxide
- B nitrogen dioxide
- C sulfur dioxide
- D sulfur trioxide

26 In separate experiments, an inert wire is dipped into two solutions, P and Q.

The wire is then placed in the flame of a Bunsen burner.

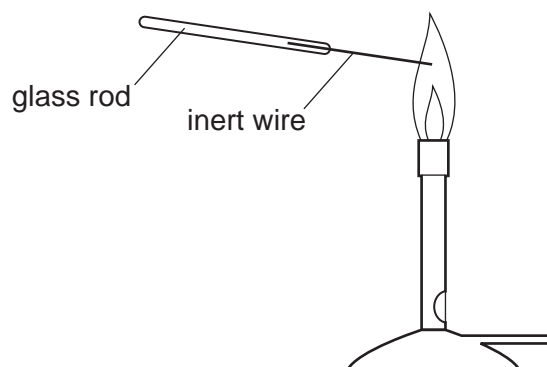

The table shows the results.

	solution P	solution Q
colour of Bunsen flame	yellow	green

Which metal ions are present in the solutions?

	P	Q
A	copper	calcium
B	copper	sodium
C	sodium	calcium
D	sodium	copper

27 Elements X and Y react together to form a compound.

The diagram shows the outer shells of X and Y after reaction.

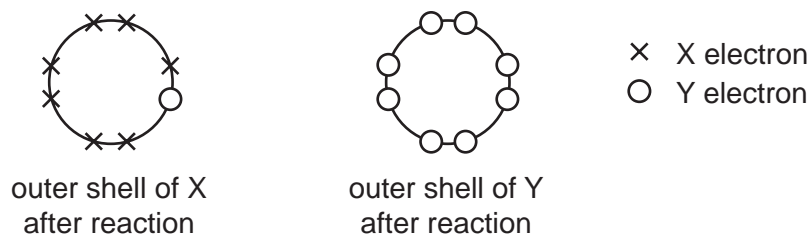

Which statement is correct?

- A X is in group VII and has formed the X^+ ion.
 - B X is in group VII and has formed the X^- ion.
 - C X is in group VIII and has formed the X^+ ion.
 - D X is in group VIII and has formed the X^- ion.
- 28 100 cm^3 of a liquid has a mass of 85 g.

How does the density of this liquid compare with the density of water (1 g/cm^3)?

- A Its density is higher than that of water.
- B Its density is lower than that of water.
- C Its density is the same as that of water.
- D It is impossible to say with only this data.

29 Four speed-time graphs are shown below.

Which graph could **not** show the motion of a car being driven normally?

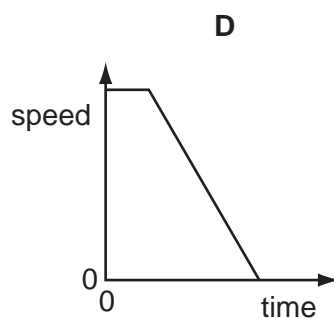
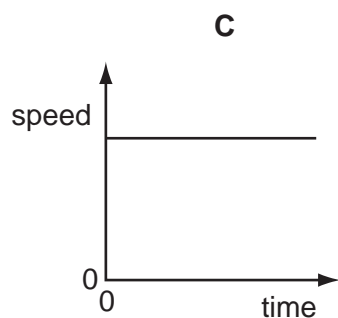
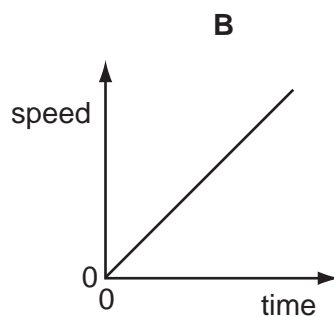
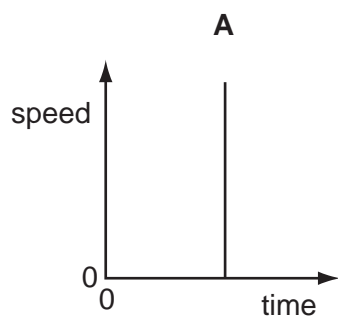

30 Four beams are each balanced on a pivot at their centres as shown. Forces are then applied to the beams as shown.

Which beam will **not** rotate when the forces shown are applied?

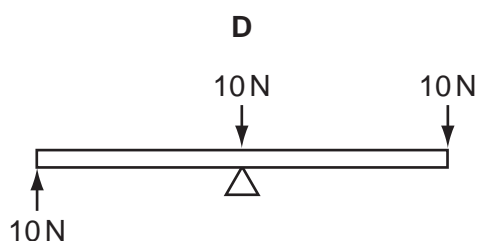
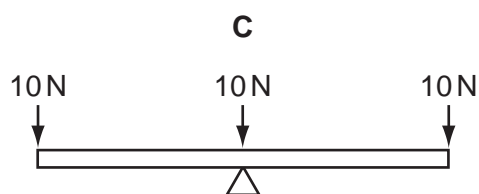
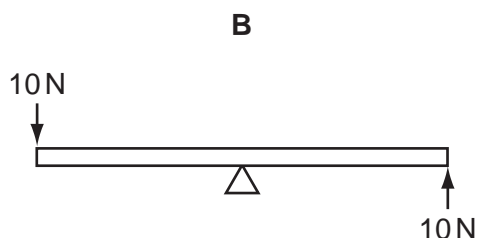
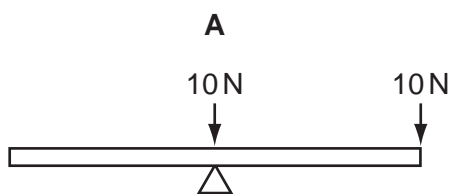

31 A man lifts some weights.

In which activity is the power of the man the **smallest**?

- A lifting a mass of 1 kg through a height of 0.1 m in 1 second
- B lifting a mass of 1 kg through a height of 0.1 m in 10 seconds
- C lifting a mass of 1 kg through a height of 1 m in 1 second
- D lifting a mass of 10 kg through a height of 0.1 m in 1 second

32 1 kg of water and 1 kg of aluminium are heated to the same temperature and then allowed to cool in a room.

Which of these could be a reason why the aluminium cools more quickly than the water?

- A Aluminium does not evaporate but water does.
- B Aluminium has a higher specific heat capacity than water.
- C Aluminium has a lower specific heat capacity than water.
- D Aluminium is a better insulator of heat than water.

33 Which diagram shows a circuit that will allow the lamps to be switched on and off independently?

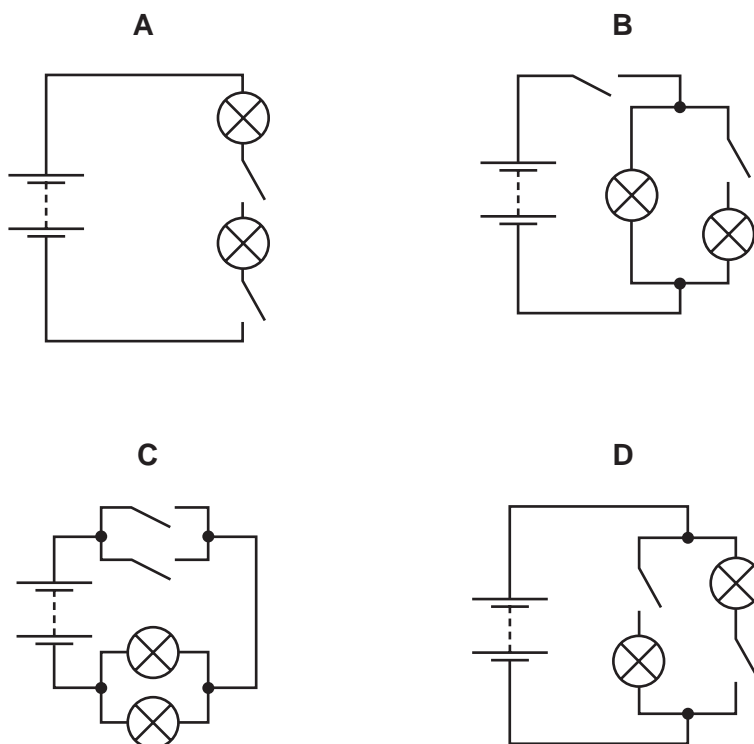

34 The diagram shows four electric kettles plugged into a 4-way adaptor.

An extension lead connects the adaptor to a single mains plug.

The mains plug is designed to work without a fuse.

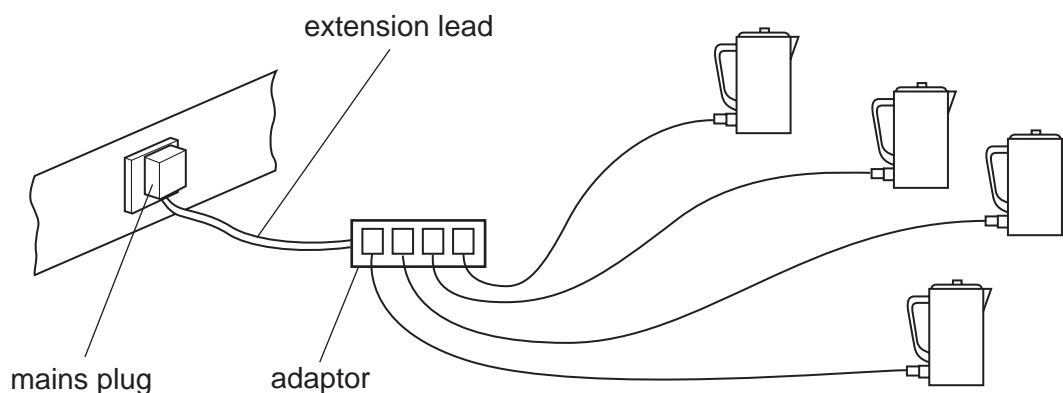

Why is this use of the adaptor dangerous?

- A The extension lead connecting the adaptor to the mains plug will overheat.
- B The heating elements in the kettle will overheat.
- C The leads connecting the kettles to the adaptor will overheat.
- D The water in the kettles will overheat.

35 A circuit consists of three resistors, X, Y and Z, connected to a battery as shown in the diagram.

The potential difference across resistor Y is measured.

In which position should the voltmeter be connected to do this?

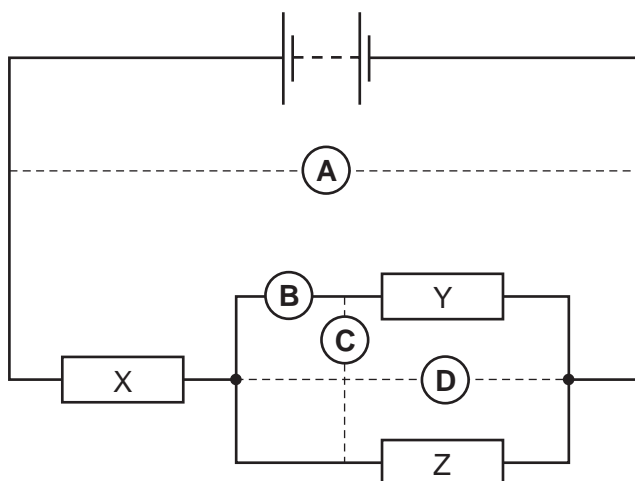

36 The diagram shows a wave.

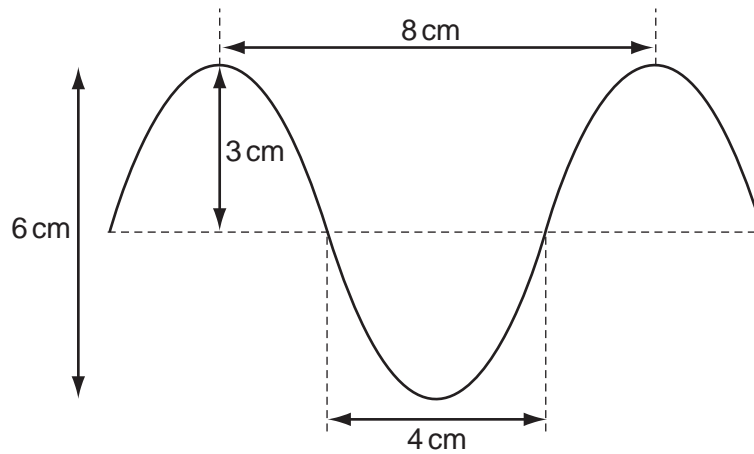

What are the amplitude and the wavelength of this wave?

	amplitude / cm	wavelength / cm
A	3	4
B	3	8
C	6	4
D	6	8

37 The diagram shows a ray of light passing from air into water.

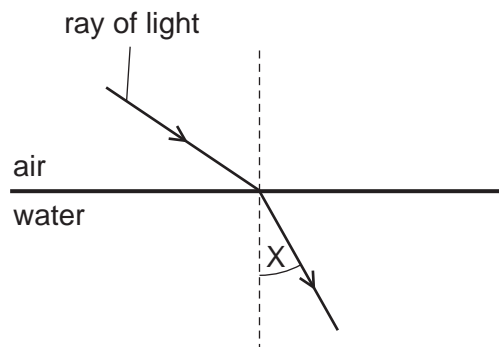

What is the name of angle X?

- A** the angle of incidence
- B** the angle of reflection
- C** the angle of refraction
- D** the critical angle

- 38 The pattern of field lines around a bar magnet on a sheet of paper can be shown by sprinkling metal filings on to the paper.

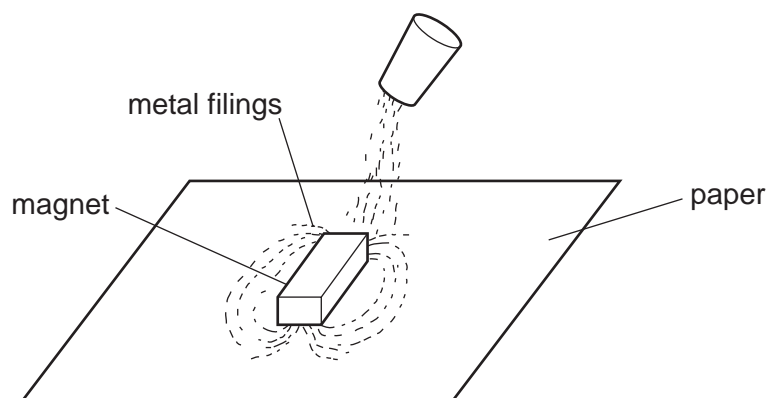

From which metal could the filings be made?

- A aluminium
 - B copper
 - C iron
 - D zinc
- 39 Compared with beta-particles and gamma-rays, alpha-particles
- A are the only radiation to carry a charge.
 - B have the greatest ionising effect.
 - C have the greatest penetrating effect.
 - D have the smallest mass.
- 40 A small amount of a substance contains 72 billion radioactive atoms. The half-life of the substance is 4 hours.

How many radioactive atoms would remain after 12 hours?

- A 6 billion
- B 9 billion
- C 18 billion
- D 24 billion

DATA SHEET
The Periodic Table of the Elements

		Group																																																																																													
I	II	III	IV	V	VI	VII	O																																																																																								
7 Li Lithium 3	9 Be Beryllium 4	1 H Hydrogen 1	11 B Boron 5	12 C Carbon 6	14 N Nitrogen 7	16 O Oxygen 8	19 F Fluorine 9	20 Ne Neon 10	23 Na Sodium 11	24 Mg Magnesium 12	27 Al Aluminium 13	28 Si Silicon 14	31 P Phosphorus 15	32 S Sulfur 16	35.5 Cl Chlorine 17	40 Ar Argon 18	39 K Potassium 19	40 Ca Calcium 20	45 Sc Scandium 21	48 Ti Titanium 22	51 V Vanadium 23	52 Cr Chromium 24	55 Mn Manganese 25	56 Fe Iron 26	59 Co Cobalt 27	59 Ni Nickel 28	64 Cu Copper 29	65 Zn Zinc 30	70 Ga Gallium 31	73 Ge Germanium 32	75 As Arsenic 33	79 Se Selenium 34	80 Br Bromine 35	84 Kr Krypton 36	85 Rb Rubidium 37	88 Sr Strontium 38	89 Y Yttrium 39	91 Zr Zirconium 40	93 Nb Niobium 41	96 Mo Molybdenum 42	101 Ru Ruthenium 44	106 Pd Palladium 46	112 Cd Cadmium 48	115 In Indium 49	119 Sn Tin 50	122 Sb Antimony 51	128 Te Tellurium 52	131 Xe Xenon 54	133 Cs Caesium 55	137 Ba Barium 56	139 La Lanthanum 57	178 Hf Hafnium 72	181 Ta Tantalum 73	184 W Tungsten 74	190 Os Osmium 76	192 Ir Iridium 77	195 Pt Platinum 78	197 Au Gold 79	201 Hg Mercury 80	204 Tl Thallium 81	207 Pb Lead 82	209 Bi Bismuth 83	210 Po Polonium 84	210 At Astatine 85	210 Rn Radon 86	226 Ra Radium 88	227 Ac Actinium 89	232 Th Thorium 90	232 Pa Protactinium 91	238 U Uranium 92	238 Np Neptunium 93	238 Pu Plutonium 94	238 Am Americium 95	238 Cm Curium 96	238 Bk Berkelium 97	238 Cf Californium 98	238 Es Einsteinium 99	238 Fm Fermium 100	238 Md Mendelevium 101	238 No Nobelium 102	238 Lr Lawrencium 103	140 Ce Cerium 58	141 Pr Praseodymium 59	144 Nd Neodymium 60	147 Pm Promethium 61	150 Sm Samarium 62	152 Eu Europium 63	157 Gd Gadolinium 64	159 Tb Terbium 65	162 Dy Dysprosium 66	165 Ho Holmium 67	167 Er Erbium 68	169 Tm Thulium 69	173 Yb Ytterbium 70	175 Lu Lutetium 71

*58-71 Lanthanoid series
†90-103 Actinoid series

a	X	b
---	----------	---

Key
a = relative atomic mass
X = atomic symbol
b = proton (atomic) number

The volume of one mole of any gas is 24 dm³ at room temperature and pressure (r.t.p.).

Permission to reproduce items where third-party owned material protected by copyright is included has been sought and cleared where possible. Every reasonable effort has been made by the publisher (UCLES) to trace copyright holders, but if any items requiring clearance have unwittingly been included, the publisher will be pleased to make amends at the earliest possible opportunity.

University of Cambridge International Examinations is part of the Cambridge Assessment Group. Cambridge Assessment is the brand name of University of Cambridge Local Examinations Syndicate (UCLES), which is itself a department of the University of Cambridge.