

UNIVERSITY OF CAMBRIDGE INTERNATIONAL EXAMINATIONS
International General Certificate of Secondary Education

CO-ORDINATED SCIENCES

0654/01

Paper 1 Multiple Choice

October/November 2005

45 minutes

Additional Materials: Multiple Choice Answer Sheet
Soft clean eraser
Soft pencil (type B or HB is recommended)

READ THESE INSTRUCTIONS FIRST

Write in soft pencil.

Do not use staples, paper clips, highlighters, glue or correction fluid.

Write your name, Centre number and candidate number on the answer sheet in the spaces provided unless this has been done for you.

There are **forty** questions on this paper. Answer **all** questions.

For each question there are four possible answers **A, B, C** and **D**. Choose the **one** you consider correct and record your choice in **soft pencil** on the separate answer sheet.

Read the instructions on the answer sheet very carefully.

Each correct answer will score one mark. A mark will not be deducted for a wrong answer.

Any rough working should be done in this booklet.

A copy of the Periodic Table is printed on page 20.

This document consists of **18** printed pages and **2** blank pages.



- 1 The diagram shows a dolphin, a mammal that lives in the sea.

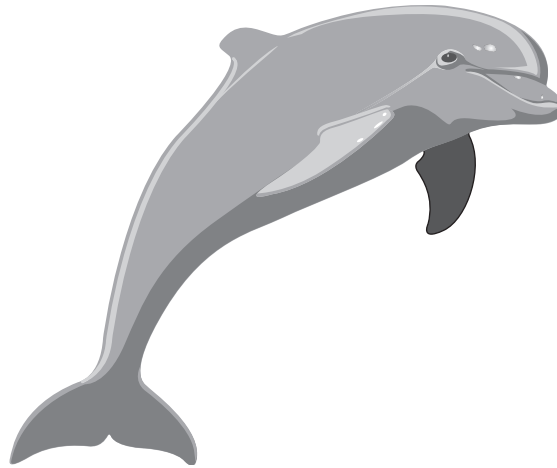

Which feature identifies a dolphin as a mammal?

- A constant body temperature
 - B lays eggs
 - C scaly skin
 - D swims with fins
- 2 The diagram shows a partially permeable membrane through which molecules pass only by osmosis.

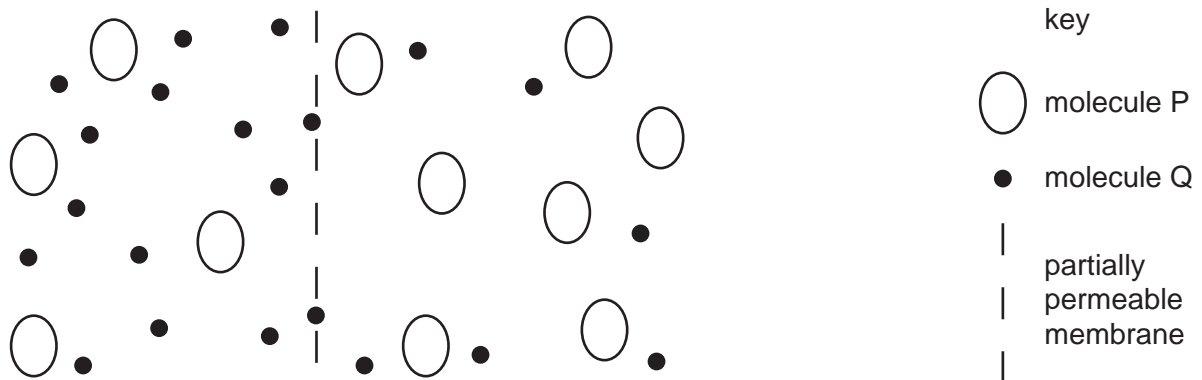

What is molecule Q?

- A amino acid
- B starch
- C sugar
- D water

- 3 The diagram shows the structure of the elbow joint.

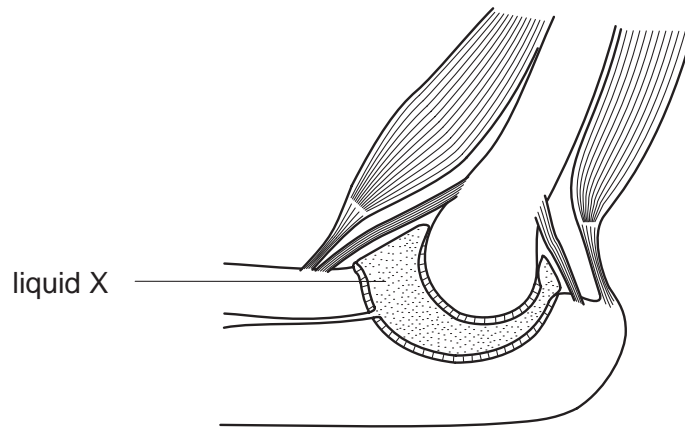

What is the function of liquid X?

- A attaching the bones to one another
 - B reducing friction during movement
 - C supplying oxygen to the tissues
 - D supporting the joint
- 4 The diagram shows a leaf, still attached to a plant, with both green and white regions that have been partly covered with black paper.

The leaf is left in bright light for six hours and then tested for starch.

Which area of the leaf turns blue-black after the starch test?

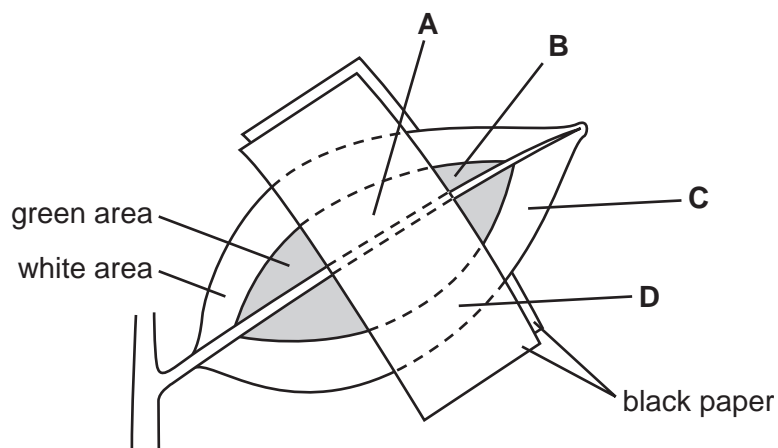

- 5 What occurs in aerobic respiration?
- A production of lactic acid
 - B release of energy
 - C release of oxygen
 - D storage of glucose

6 Some liquid is collected from the xylem of a plant.

What is present in the liquid?

- A amino acids
- B inorganic ions
- C starch
- D sugar

7 Which name is given to the removal, through the anus, of substances that have not been digested?

- A absorption
- B digestion
- C egestion
- D excretion

8 Kwashiorkor is a disease that affects young children who do not have enough protein to eat.

Which is the best food to add to a diet largely of carbohydrate to prevent Kwashiorkor?

- A bread
- B fish
- C fruit
- D rice

9 The diagram shows a section through the eye.

In which structure are stimuli converted to nerve impulses?

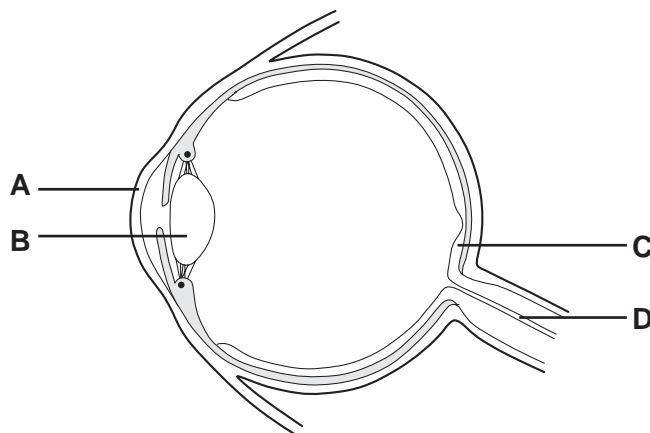

10 The diagram shows a human kidney and its blood supply.

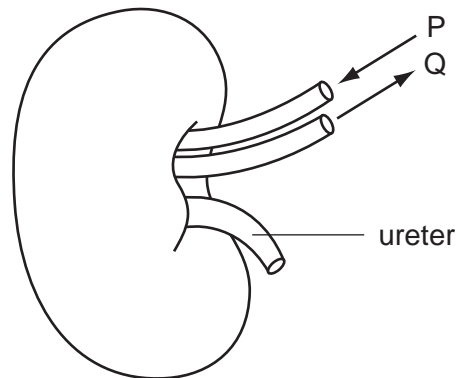

Compared with the blood in vessel P, the blood in Q has

- A less urea and less oxygen.
- B less urea and more oxygen.
- C more urea and less oxygen.
- D more urea and more oxygen.

11 The diagram shows an experiment to demonstrate that in order to germinate, pea seeds need oxygen, a suitable temperature and water.

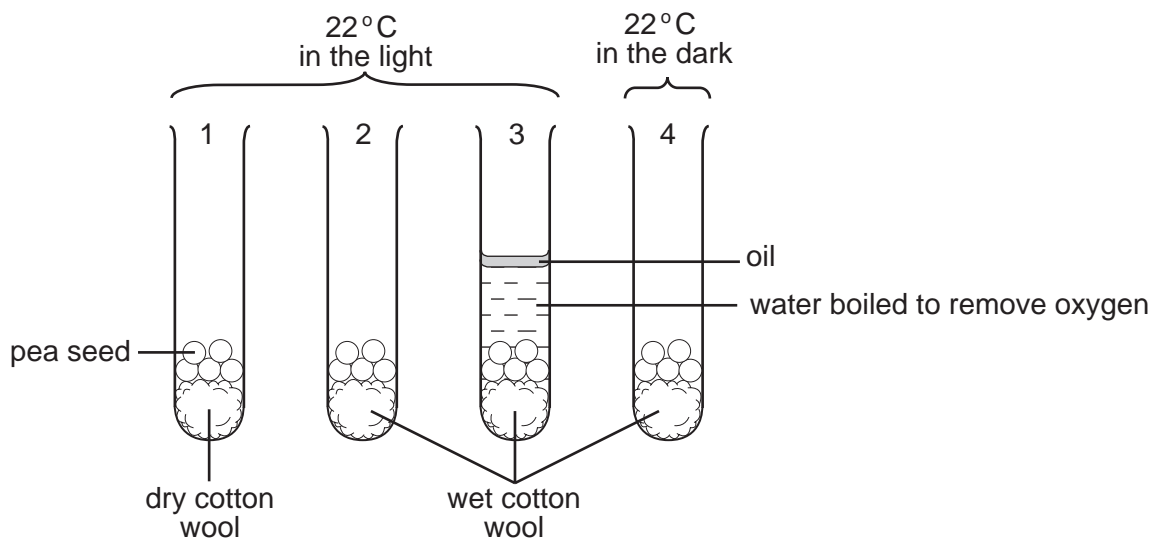

In which tubes would the seeds germinate?

- A tube 2 only
- B tubes 1 + 2 only
- C tubes 2 + 3 only
- D tubes 2 + 4 only

12 The table gives information about a human sperm and a human egg.

Which information is correct?

	sperm		egg	
	where formed	chromosome number	where formed	chromosome number
A	ovary	23	testis	23
B	testis	46	ovary	46
C	ovary	46	testis	46
D	testis	23	ovary	23

13 An example of a food chain is shown.

large water plants → small fish → large fish → decomposers

What is the source of energy for the large water plants in this food chain?

- A** decomposers
- B** sunlight
- C** wastes from the small fish
- D** water

14 An ice cube is gently warmed as shown.

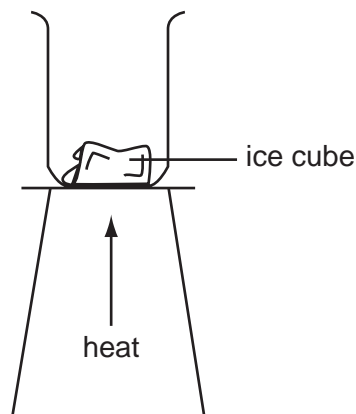

Which process is taking place?

- A** decomposition
- B** dissolving
- C** distillation
- D** melting

15 Which words correctly complete gaps 1, 2 and 3 below?

Molecules of1..... join together to form2..... that is thermoplastic and3..... on heating.

	gap 1	gap 2	gap 3
A	a monomer	a polymer	hardens
B	a monomer	a polymer	softens
C	a polymer	a monomer	hardens
D	a polymer	a monomer	softens

16 The structure of sugar obtained from plants may be simplified as shown.



Compound **X**, also obtained from plants, has the following structure.



What could **X** be?

	protein	starch
A	✓	✓
B	✓	x
C	x	✓
D	x	x

17 A solid has a giant structure. It does not conduct electricity but does so when it is dissolved in water.

What could the solid be?

	copper(II) chloride	graphite
A	✓	✓
B	✓	x
C	x	✓
D	x	x

18 The diagram shows a metal being extracted from its powdered ore.

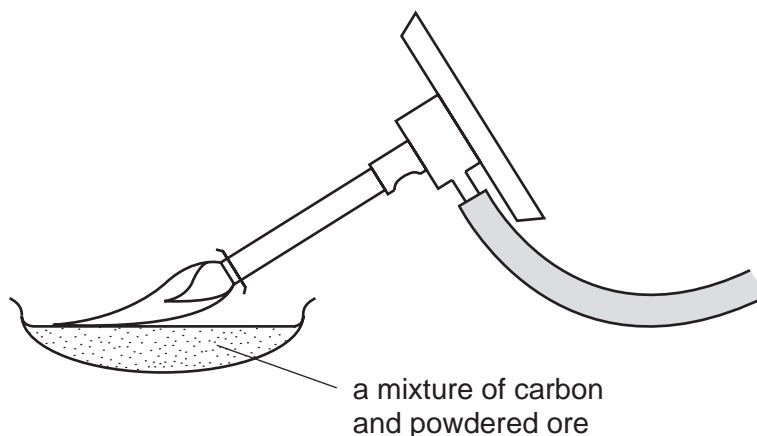

What happens to the ore in this reaction?

- A it burns
- B it decomposes
- C it is oxidised
- D it is reduced

19 Limestone and common salt are important minerals.

For which process are **both** minerals suitable starting materials?

- A manufacture of alkalis
- B manufacture of chlorine
- C manufacture of fertilisers
- D manufacture of hydrogen

20 A man spills ink on his polyester shirt.

The table shows the solubility of ink and of polyester in four solvents.

Which solvent should be used to remove the ink?

solvent	ink	polyester
A	insoluble	insoluble
B	insoluble	soluble
C	soluble	insoluble
D	soluble	soluble

21 The table shows the pH values of four solutions.

Which solution produces an exothermic reaction when mixed with a dilute acid?

solution	pH
A	10
B	7
C	4
D	1

22 Which types of change take place during the weathering of rock?

	chemical change	physical change
A	✓	✓
B	✓	x
C	x	✓
D	x	x

23 Nitrogen from the air is used to manufacture the fertiliser ammonium sulphate.

Why is a catalyst needed during this process?

- A** Nitrogen from the air is not pure.
- B** Nitrogen is a gas at room temperature.
- C** Nitrogen is a non-metallic element.
- D** Nitrogen reacts slowly.

24 Why is an analgesic used?

- A** to decrease acidity in the stomach
- B** to extract dye from a plant
- C** to make an emulsion
- D** to relieve pain

- 25 An experiment using olive oil and water is shown. Liquid X is added and the contents of the test-tube are shaken.

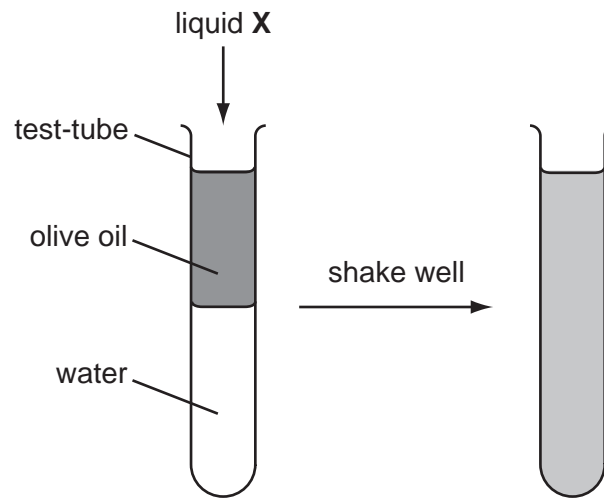

How is liquid X described?

- A a colloid
- B an emulsifier
- C a gel
- D a sol

26 In an experiment on rusting, pieces of iron were kept under four different conditions. They were weighed at regular intervals.

The graph shows the four results.

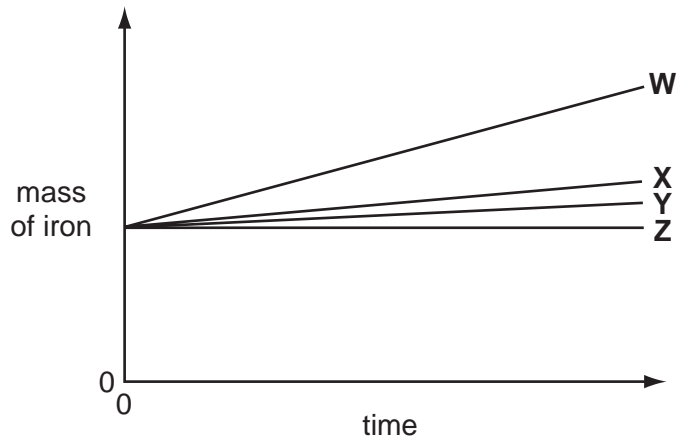

Which experiment would give graph **W**?

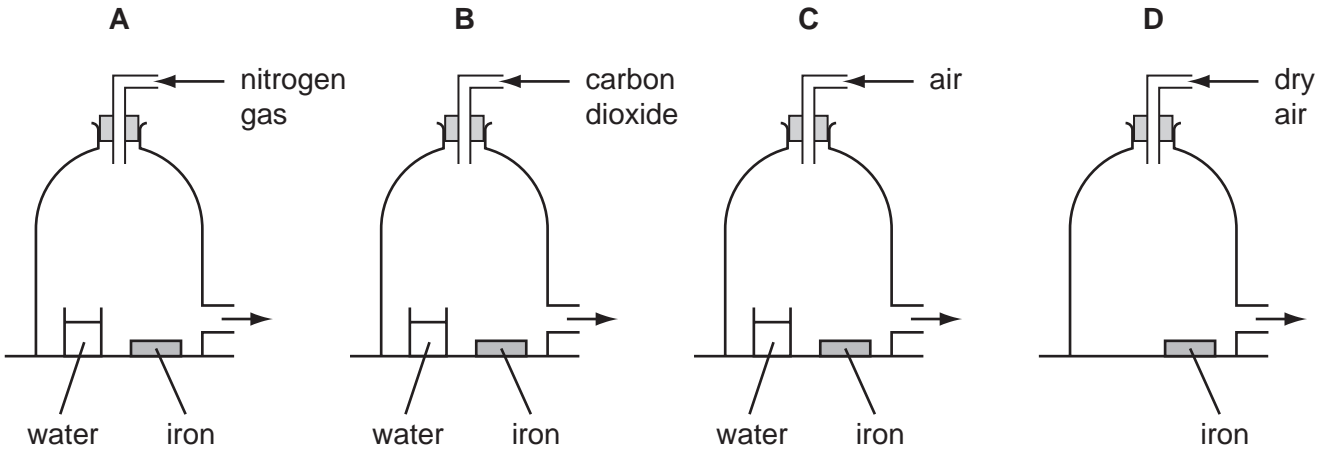

27 Which diagram represents an alloy?

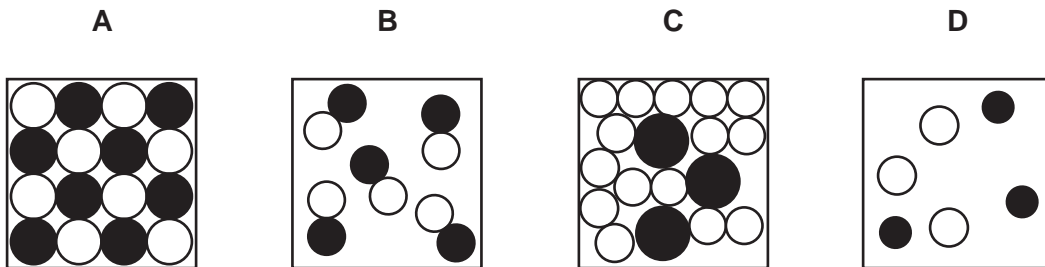

28 A measuring cylinder is used to measure the volume of a liquid.

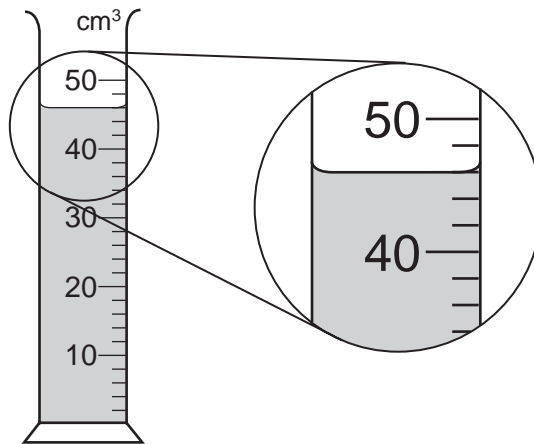

What is the volume of the liquid?

- A** 43 cm³ **B** 46 cm³ **C** 48 cm³ **D** 54 cm³

29 A man crosses a road 8.0 m wide at a speed of 2.0 m/s.

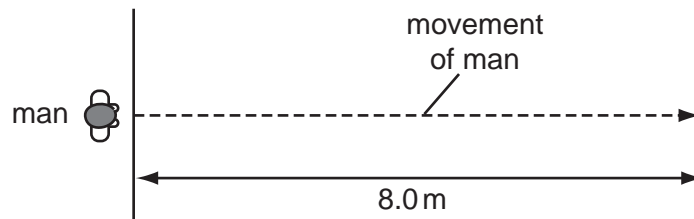

How long does the man take to cross the road?

- A** 4.0 s **B** 6.0 s **C** 10 s **D** 16 s

30 A sports car has a mass of 750 kg and a saloon car has a mass of 1500 kg. They are both moving at the same speed.

The sports car has

- A** half the momentum of the saloon car.
B the same momentum as the saloon car.
C double the momentum of the saloon car.
D four times the momentum of the saloon car.

31 Four blocks, each weighing 10 N, rest on a horizontal table.

Which block applies the greatest pressure on the table?

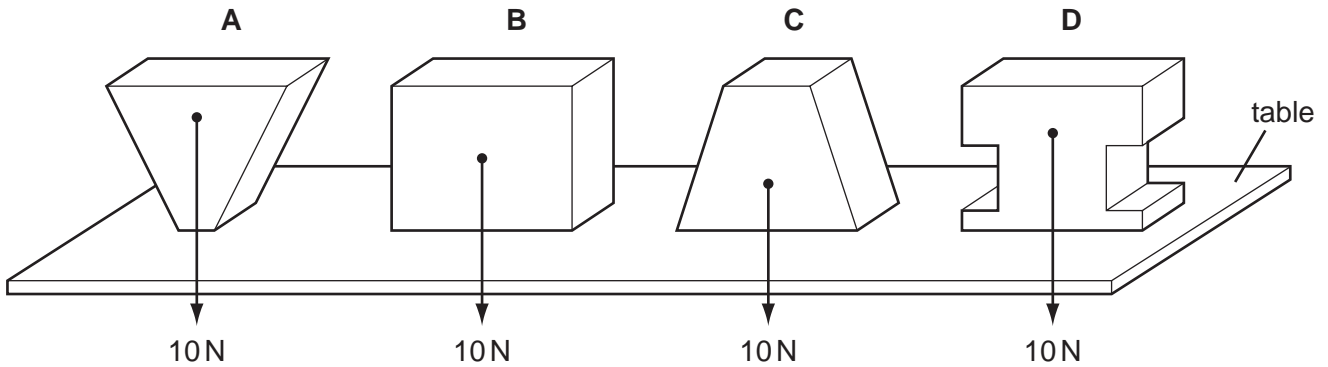

32 The diagram shows a cooling unit in a refrigerator.

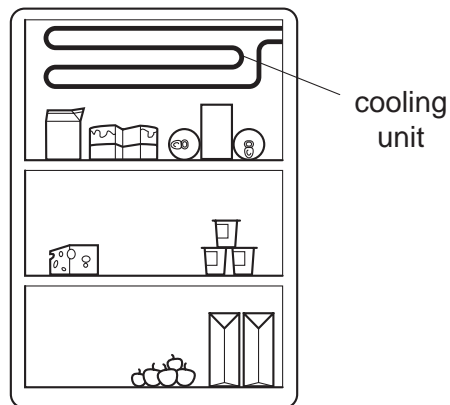

Why is the cooling unit placed at the top?

- A Cold air falls and warm air is displaced upwards.
- B Cold air is a bad conductor so heat is not conducted into the refrigerator.
- C Cold air is a good conductor so heat is conducted out of the refrigerator.
- D Cold air stops at the top and so prevents convection.

33 The diagrams show four sources of waves.

Which source generates longitudinal waves?



stick pushed up
and down in water

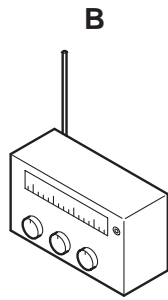

radio
transmitter

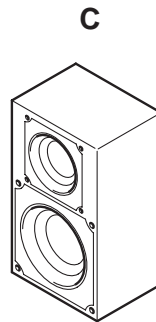

loudspeaker



lamp

34 Rays of light enter and leave a box.

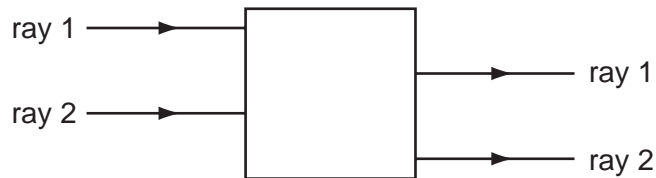

What could be inside the box to make the rays behave as shown?

- A** a converging lens
- B** a parallel-sided glass block
- C** a plane mirror
- D** a triangular prism

35 Two rods X and Y look the same.

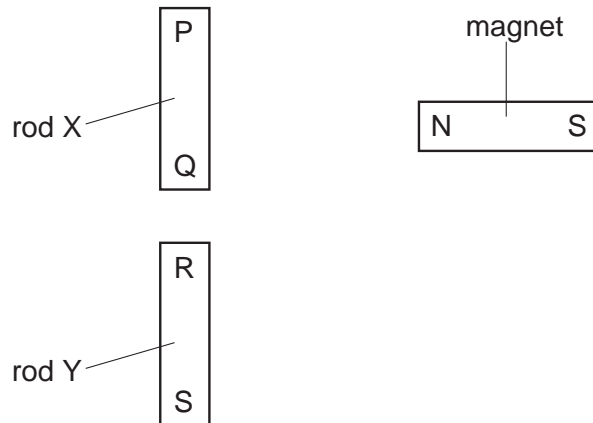

The N pole of a magnet is brought close, in turn, to each end of both rods. The results of these four actions are shown in the table.

end tested	result
P	attraction
Q	attraction
R	attraction
S	repulsion

Which of the rods is a magnet?

- A neither of the rods
- B both of the rods
- C rod X only
- D rod Y only

36 The table shows the voltage and current ratings for four electric heaters.

Which heater has the least resistance?

	voltage / V	current / A
A	110	5.0
B	110	10
C	230	5.0
D	230	10

37 When the circuit shown is connected with switch S open, the 6 V lamp glows.

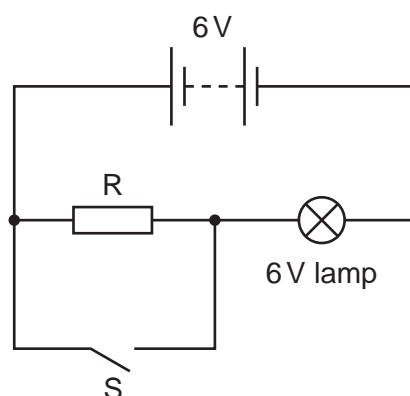

What happens to the brightness of the lamp when switch S is closed?

- A It becomes brighter.
- B It remains the same.
- C It becomes dimmer.
- D It goes off.

38 The diagram shows the earpiece of a telephone.

Which part of the earpiece moves in order to produce sound?

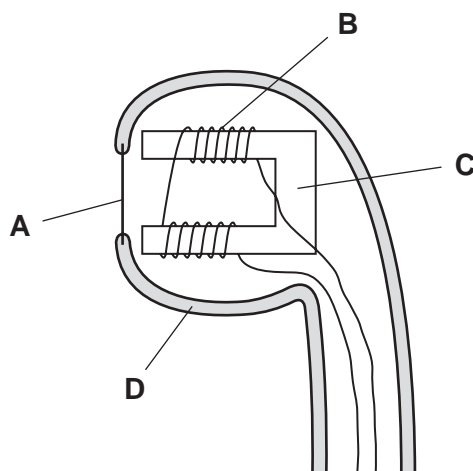

39 When light was first used to pass messages between places many kilometres apart, the problem of coding the message had to be solved.

Which of the following was a possible solution?

- A Flash white light on and off.
- B Pass white light through a prism to give a spectrum.
- C Use continuous blue light.
- D Use continuous red light.

- 40 A radioactive source emits radiation which can pass through a sheet of paper but not through thick aluminium.

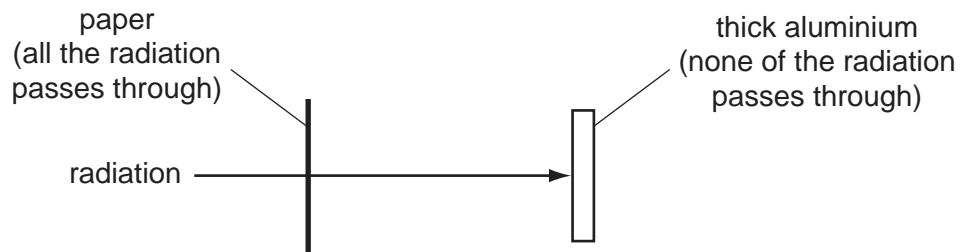

What does this show about the radiation?

- A It is alpha-particles.
- B It is beta-particles.
- C It is gamma-rays.
- D It is a mixture of alpha-particles and gamma-rays.

DATA SHEET
The Periodic Table of the Elements

		Group																	
		I	II	III	IV	V	VI	VII	VIII	IX	X								
		1 H Hydrogen 1																	
		2 He Helium 2																	
3	4	7 Li Lithium	9 Be Beryllium																
11	12	23 Na Sodium	24 Mg Magnesium																
19	20	39 K Potassium	40 Ca Calcium																
37	38	85 Rb Rubidium	88 Sr Strontium	45 Sc Scandium	48 Ti Titanium	51 V Vanadium	52 Cr Chromium	55 Mn Manganese	56 Fe Iron	59 Co Cobalt	58 Ni Nickel	64 Cu Copper	65 Zn Zinc	70 Ga Gallium	73 Ge Germanium	75 As Arsenic	79 Se Selenium	80 Br Bromine	84 Kr Krypton
55	56	133 Cs Caesium	137 Ba Barium	89 Y Yttrium	91 Zr Zirconium	93 Nb Niobium	96 Mo Molybdenum	101 Ru Ruthenium	106 Pd Palladium	103 Rh Rhodium	100 Pt Platinum	108 Ag Silver	112 Cd Cadmium	115 In Indium	119 Sn Tin	122 Sb Antimony	128 Te Tellurium	127 I Iodine	131 Xe Xenon
87	88	139 Fr Francium	226 Ra Radium	139 La Lanthanum	178 Hf Hafnium	181 Ta Tantalum	184 W Tungsten	190 Os Osmium	195 Pt Platinum	192 Ir Iridium	197 Au Gold	201 Hg Mercury	204 Tl Thallium	207 Pb Lead	209 Bi Bismuth	210 Po Polonium	210 At Astatine	210 Rn Radon	

*58-71 Lanthanoid series
90-103 Actinoid series

Key

a	X
= relative atomic mass	
= atomic symbol	
= proton (atomic) number	

140 Ce Cerium	141 Pr Praseodymium	144 Nd Neodymium	150 Sm Samarium	152 Eu Europium	157 Gd Gadolinium	159 Tb Terbium	162 Dy Dysprosium	165 Ho Holmium	167 Er Erbium	169 Tm Thulium	173 Yb Ytterbium	175 Lu Lutetium
90 Th Thorium	91 Pa Protactinium	92 U Uranium	94 Pu Plutonium	95 Am Americium	96 Cm Curium	97 Bk Berkelium	98 Cf Californium	99 Es Einsteinium	100 Fm Fermium	101 Md Mendelevium	102 No Nobelium	103 Lr Lawrencium

The volume of one mole of any gas is 24 dm³ at room temperature and pressure (r.t.p.).