



UNIVERSITY OF CAMBRIDGE INTERNATIONAL EXAMINATIONS
International General Certificate of Secondary Education

CO-ORDINATED SCIENCES

0654/52

Paper 5 Practical Test

May/June 2010

CONFIDENTIAL INSTRUCTIONS

Great care should be taken to ensure that any confidential information given does not reach the candidates either directly or indirectly.

The Supervisor's attention is drawn to the form on page 8 which must be completed and returned with the scripts.

If you have any queries regarding these instructions, please contact CIE

by e-mail: International@cie.org.uk

by phone: +44 1223 553554

by fax +44 1223 553558

stating the nature of the query and the syllabus number quoted above.

This document consists of **6** printed pages and **2** blank pages.



Instructions for preparing apparatus

These instructions detail the apparatus, reagents and specimens required by each candidate for each experiment in this paper. A summary of the questions that will be presented to the candidates is included, where appropriate, to allow the teacher to test the apparatus appropriately. **No access is permitted to the question paper in advance of the examination session.**

It is assumed that the ordinary apparatus of a science laboratory will be available, including a supply of purified water (distilled or deionised).

If arrangements are made for different sessions for different groups of candidates, care must be taken to ensure that the different groups of candidates are effectively isolated so that **no information passes between them.**

For question 1

Each candidate will need:

- (i) 20 dicotyledonous leaves of the same species. The shape of the leaves should be chosen so that the length can easily be measured. A typical leaf could be this shape.

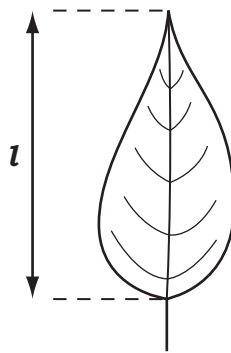

The leaves can be any length between 30 mm and 150 mm. Please make sure that there is at least 20 mm difference between the shortest and longest length;

Please label the 20 leaves with a number attached to each petiole.

It is possible for more than one candidate to use the same set of leaves.

- (ii) a ruler graduated in millimetres.

Note to supervisors.

Please enter the species of the leaves used and draw a rough sketch of one of them on the grid provided, on page 7.

For question 2

Each candidate will need:

- (i) a “tin” can. This should be a food can which is iron layered with tin. The size is **not** important. An aluminium can should not be used ;
- (ii) suitable lagging to insulate the can ;
- (iii) a thermometer 0 – 100 °C ;
- (iv) a 100 cm³ measuring cylinder ;
- (v) a beaker, at least the size of the can ;
- (vi) a means of heating a beaker of water. The amount of water should be enough to fill about one third the can ;
- (vii) a balance to enable the can to be weighed to the nearest gram.

For question 3

Each candidate will need:

- (i) a 150 x 25 mm test-tube fitted with a delivery tube. The tube will need to allow any gas evolved to pass through water and be collected in an upturned measuring cylinder ;

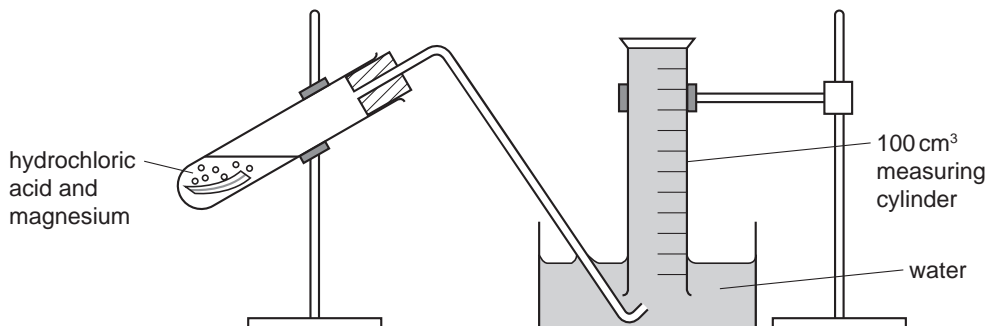

- (ii) a 100 cm³ measuring cylinder ;
- (iii) a 10 cm³ measuring cylinder ;
- (iv) two retort stands and clamps ;
- (v) a trough of water. This needs to be of sufficient size to allow the delivery tube to enter the water and pass any gas into the measuring cylinder ;
- (vi) 100 cm³ of approximately 2 mol dm⁻³ hydrochloric acid, labelled hydrochloric acid ;
- (vii) a strip of magnesium ribbon 30 cm long ;
- (viii) a pair of scissors ;
- (ix) a 30 cm ruler ;
- (x) a timer or sight of clock reading in seconds.

Spare materials and equipment should be available and can be provided without penalty. **Candidates should be made aware of this.**

Information required from the Supervisor:

The Supervisor is asked to carry out the experiments and to enter the results on a spare copy of the examination paper, clearly marked 'Supervisor's Results' and showing the Centre number. This should be returned with the scripts. Failure to do so may cause the candidates to be penalised.

Sketch of leaves used for **question 1**.

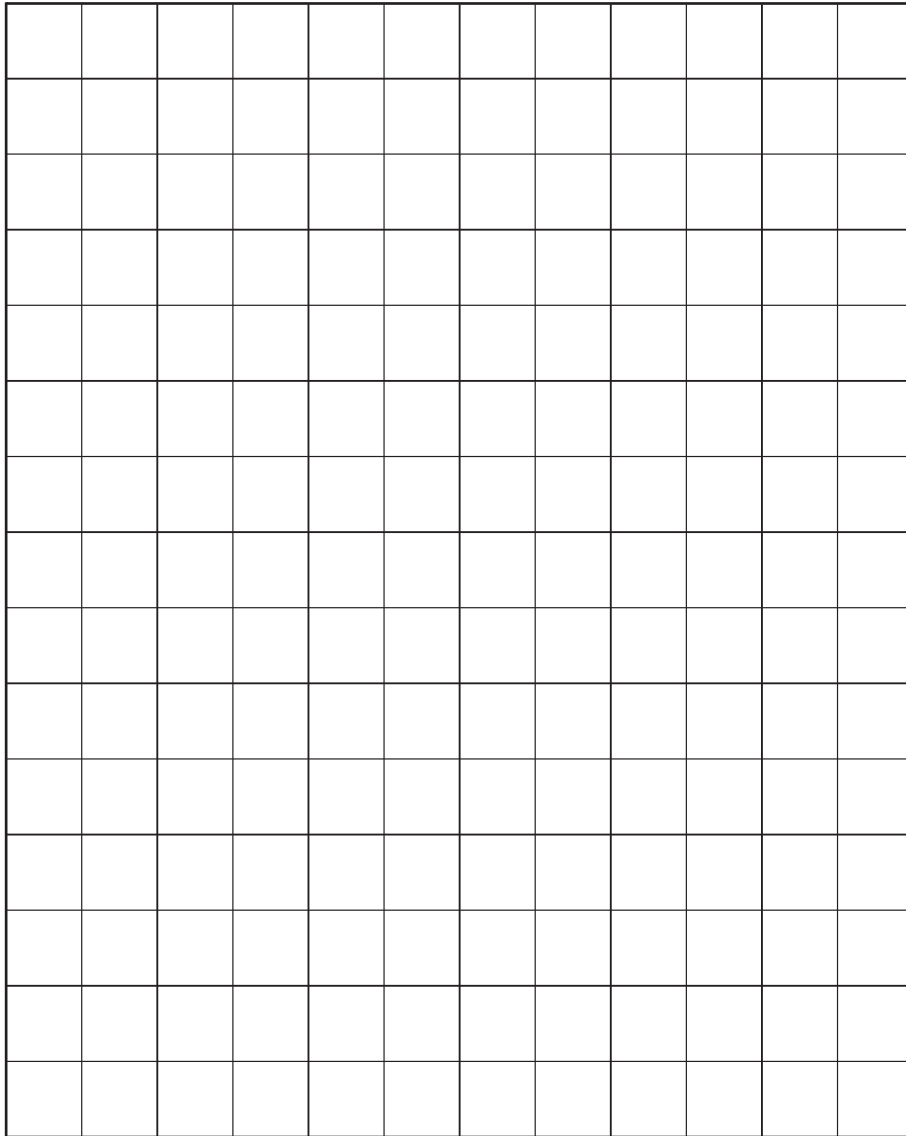

species =

approximate length of longest leaf = mm

approximate length of shortest leaf = mm

This form must be completed and returned in the envelope with the scripts together with the seating plan and the Supervisor's Results mentioned on page 4.

May/June 2010

General

The Supervisor is invited to give details of any difficulties experienced by particular candidates giving their names and candidate numbers. These should include reference to:

- (a) difficulties due to faulty apparatus;
- (b) accidents to apparatus or materials;
- (c) physical handicaps, e.g. short sight, colour blindness;
- (d) any other information that is likely to assist the Examiner, especially if this cannot be discovered in the scripts;
- (e) any help given to a candidate.

The Supervisor is asked to supply the following information:

Plan of work benches, giving details by candidate numbers of the places occupied by the candidates for each session and a copy of the 'Supervisor's Results'.

NAME OF CENTRE

SIGNED
Supervisor

CENTRE NUMBER

DECLARATION (to be signed by the Principal)

The preparation of this practical examination has been carried out so as to maintain fully the security of the examination.

NAME
(in block capitals)

SIGNED (Principal)



Permission to reproduce items where third-party owned material protected by copyright is included has been sought and cleared where possible. Every reasonable effort has been made by the publisher (UCLES) to trace copyright holders, but if any items requiring clearance have unwittingly been included, the publisher will be pleased to make amends at the earliest possible opportunity.

University of Cambridge International Examinations is part of the Cambridge Assessment Group. Cambridge Assessment is the brand name of University of Cambridge Local Examinations Syndicate (UCLES), which is itself a department of the University of Cambridge.