

UNIVERSITY OF CAMBRIDGE INTERNATIONAL EXAMINATIONS
International General Certificate of Secondary Education

CO-ORDINATED SCIENCES

0654/01

Paper 1 Multiple Choice

May/June 2006

45 minutes

Additional Materials: Multiple Choice Answer Sheet
Soft clean eraser
Soft pencil (type B or HB is recommended)

READ THESE INSTRUCTIONS FIRST

Write in soft pencil.

Do not use staples, paper clips, highlighters, glue or correction fluid.

Write your name, Centre number and candidate number on the Answer Sheet in the spaces provided unless this has been done for you.

There are **forty** questions on this paper. Answer **all** questions. For each question there are four possible answers **A, B, C** and **D**.

Choose the **one** you consider correct and record your choice in **soft pencil** on the separate Answer Sheet.

Read the instructions on the Answer Sheet very carefully.

Each correct answer will score one mark. A mark will not be deducted for a wrong answer.

Any rough working should be done in this booklet.

A copy of the Periodic Table is printed on page 20.

This document consists of **17** printed pages and **3** blank pages.



1 The diagram shows a bone from the human arm.



Use the key to identify the bone.

- i Has a distinct socket at one end..... go to ii
Has no distinct socket at one end..... go to iii
- ii Broad and flat in shape..... **A**
Rod-like in shape..... **B**
- iii Has a rounded structure that fits into a socket..... **C**
Has no rounded structure..... **D**

2 The diagram shows four cells.

Which cell is a plant cell?

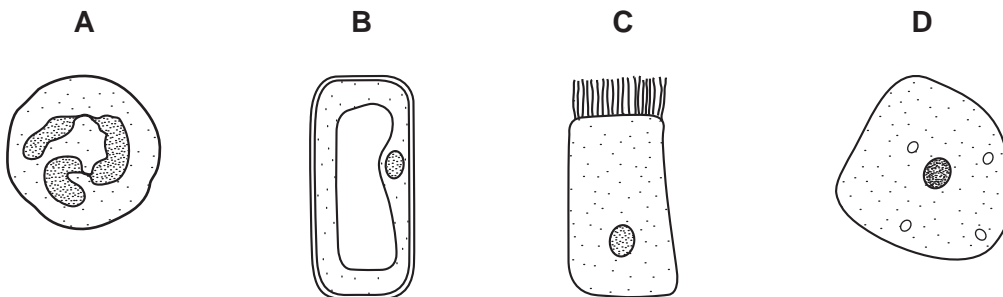

3 The diagram shows two stages in the growth of a plant inside a black box.

Light enters the box through a hole in one side.

Which part is the effector?

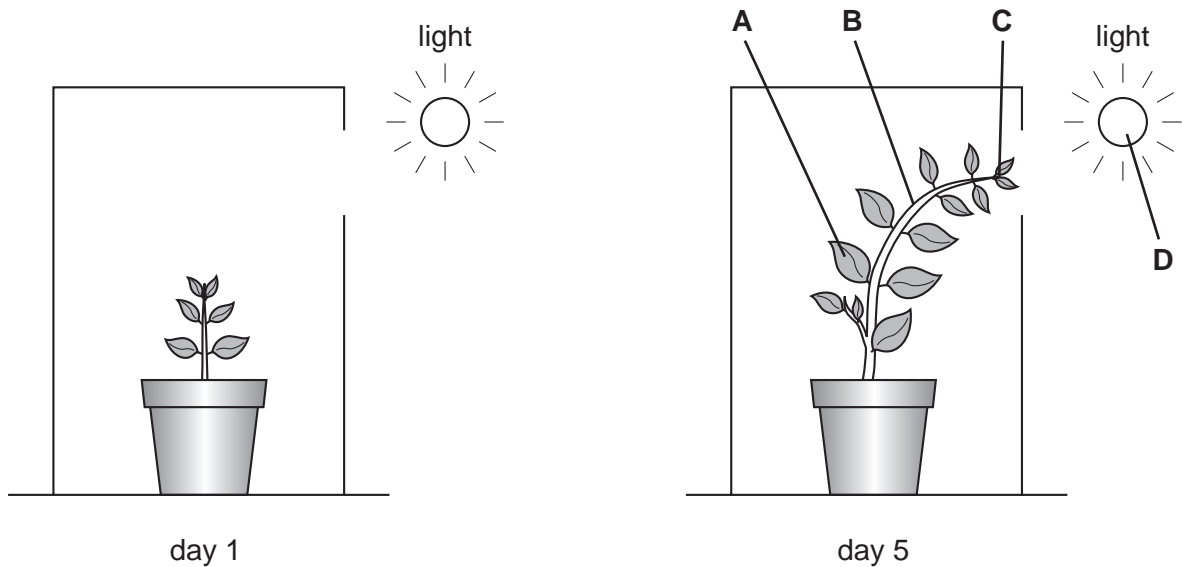

4 Air is moved in and out of the lungs by changes in the volume of the chest cavity.

In which structure are there muscles that help to bring this about?

- A alveolus
- B bronchus
- C diaphragm
- D trachea

5 From which chamber of the human heart is blood pumped most strongly?

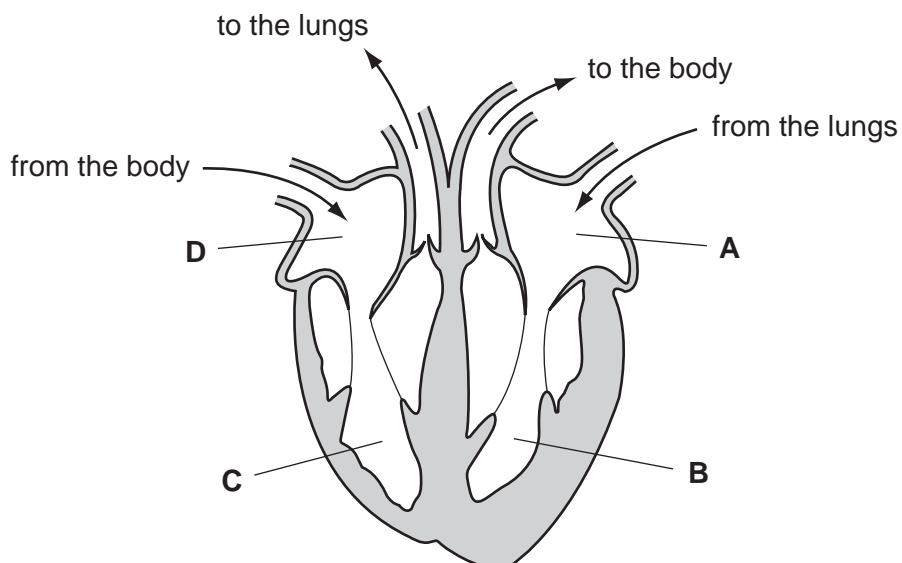

- 6 The graph shows how a person's body temperature changes with changing air temperature.

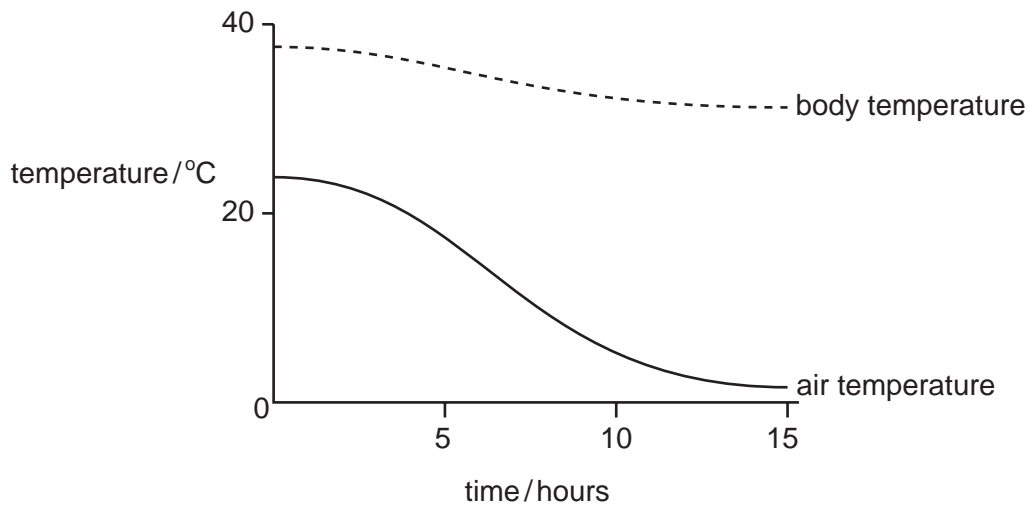

Which process provides the energy for maintaining the body temperature as shown in the graph?

- A breathing
 - B digestion
 - C excretion
 - D respiration
- 7 A food contains reducing sugar, but no starch.

What colours will be obtained if samples of the food are tested with Benedict's reagent and with iodine solution?

	Benedict's test	iodine test
A	blue	blue-black
B	blue	brown
C	red-orange	blue-black
D	red-orange	brown

- 8 Which bones form a joint at the shoulder?
- A humerus and radius
 - B humerus and scapula
 - C ulna and radius
 - D ulna and scapula

- 9 The graphs show changes in the amount of sugar in the blood after a person has eaten a sugary meal.

Which graph shows changes in the amount of blood sugar of a person with untreated diabetes?

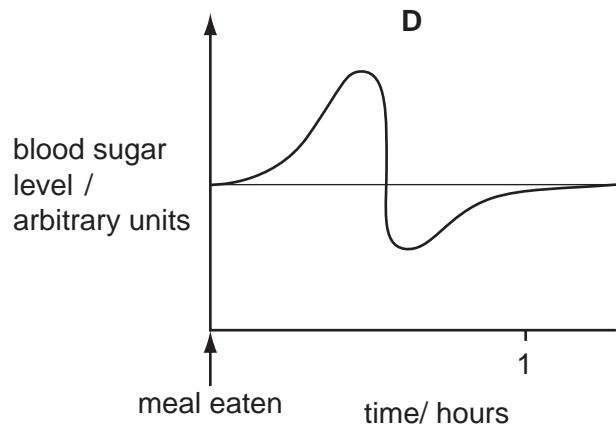
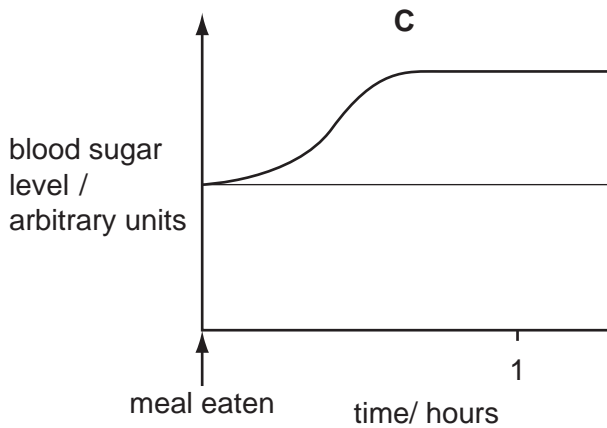
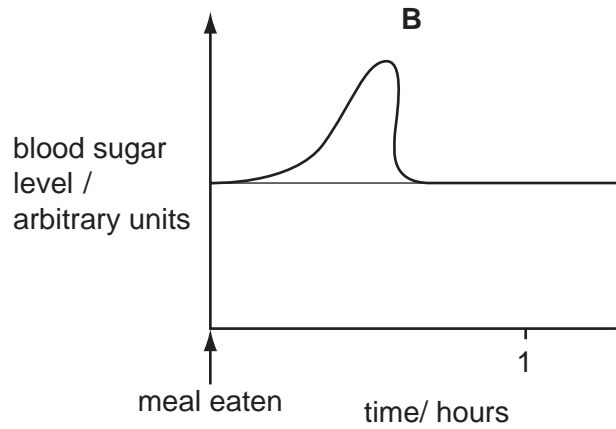
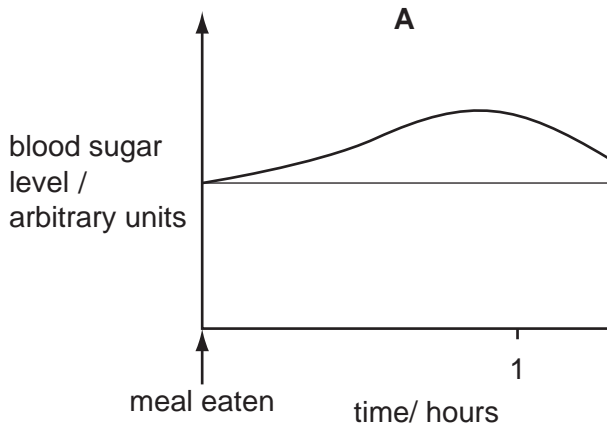

- 10 Where does fertilisation take place in a flowering plant?

- A anther
- B bud
- C ovule
- D stigma

- 11 An organism has 28 chromosomes in each body cell.

How many chromosomes would there be in a gamete of the same organism?

- A 7
- B 14
- C 28
- D 56

- 12 Dung beetles lay their eggs in the dung of plant-eating mammals like buffalo. Both the adult beetles and their young stages eat the undigested food in the dung.

Which shows this food relationship?

- A buffalo → dung beetles
buffalo → grass
- B dung beetles → grass → buffalo
- C grass → dung beetles → buffalo
- D grass → buffalo
grass → dung beetles

- 13 Which organisms increase the amount of nitrogen gas in the air?

- A decomposing bacteria
- B denitrifying bacteria
- C nitrifying bacteria
- D nitrogen fixing bacteria

- 14 The diagram shows a sack containing a mixture of three minerals.

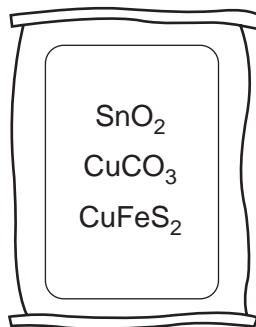

Which element is **not** present in the mixture?

- A cobalt
- B copper
- C iron
- D tin

15 Heating a metal compound in a Bunsen flame turns the flame green.

Which metal ion is present in the compound?

- A calcium
- B copper
- C potassium
- D sodium

16 Which process produces molecules with longer chains?

- A combustion of hydrocarbon
- B cracking
- C fractional distillation of crude oil
- D polymerisation

17 The diagram shows part of a polymer molecule.

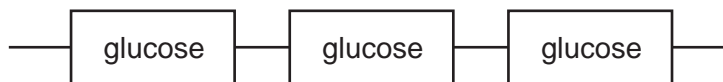

Which polymers can be represented by this diagram?

	cellulose	protein	starch
A	✓	✓	✓
B	✓	✓	x
C	✓	x	✓
D	x	✓	✓

18 The table shows the name and formula of four metal ores.

	name	formula
1	chalcopyrite	CuFeS_2
2	ilmenite	FeTiO_3
3	malachite	$\text{Cu}_2\text{CO}_3(\text{OH})_2$
4	wolframite	FeWO_4

Which metal ores contain two different metals?

- A 1 and 3 only
- B 2 and 4 only
- C 1, 2 and 4 only
- D 2, 3 and 4 only

19 Compound **X** is an important industrial raw material.

Products obtained from the electrolysis of its concentrated aqueous solution include:

- a gas that bleaches damp litmus paper,
- a gas that ignites with a pop,
- an alkali.

What is compound **X**?

- A copper(II) sulphate
- B hydrochloric acid
- C sodium carbonate
- D sodium chloride

- 20 Small amounts of barium nitrate and sand are shaken with separate samples of water in two test-tubes. The test-tubes are left to stand.

Which two diagrams show the behaviour of the barium nitrate and sand?

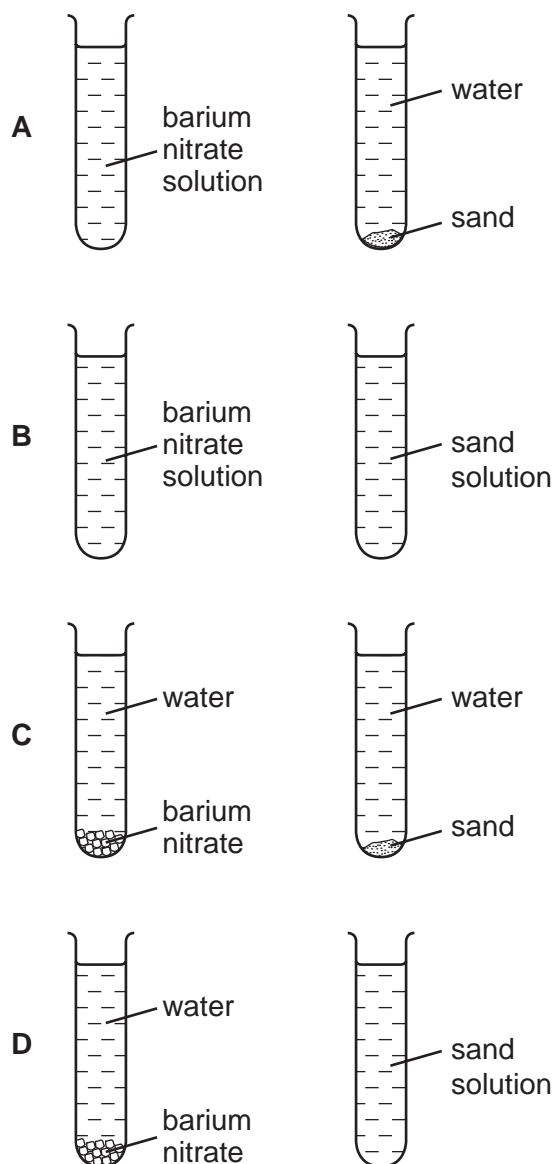

- 21 A sample of tap water forms a scum, rather than a lather, with soap solution.

This shows that the tap water is ...X... and that it contains ...Y... ions.

What are X and Y?

	X	Y
A	hard	calcium
B	hard	sodium
C	soft	calcium
D	soft	sodium

22 Modern synthetic dyes have largely replaced natural plant dyes.

This is because, compared with natural plant dyes, synthetic dyes ...X... readily fade in sunlight and can be made in a ...Y... choice of colours.

Which words correctly complete gaps X and Y?

	X	Y
A	less	bigger
B	less	smaller
C	more	bigger
D	more	smaller

23 How may the compounds in chlorophyll be separated?

- A** chemotherapy
- B** chromatography
- C** distillation
- D** emulsification

24 A fuel used for cooking food is the hydrocarbon ...X... that burns in an ...Y... reaction.

Which words correctly complete gaps X and Y?

	X	Y
A	coke	endothermic
B	coke	exothermic
C	methane	endothermic
D	methane	exothermic

28 A measuring cylinder contains some water. When a stone is put in the water, the level rises.

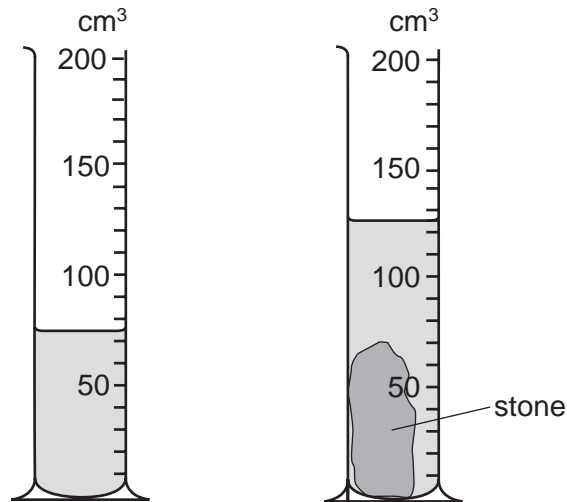

What is the volume of the stone?

- A** 50 cm³ **B** 70 cm³ **C** 75 cm³ **D** 125 cm³

29 A child is standing on the platform of a station, watching the trains.

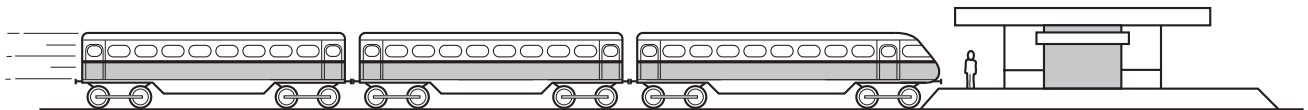

A train travelling at 30 m/s takes 3 s to pass the child.

What is the length of the train?

- A** 10m **B** 30m **C** 90m **D** 135m

30 Which form of energy do we receive directly from the Sun?

- A** chemical
B light
C nuclear
D sound

31 The diagram shows a thick sheet of glass.

Which edge must it stand on to cause the greatest pressure?

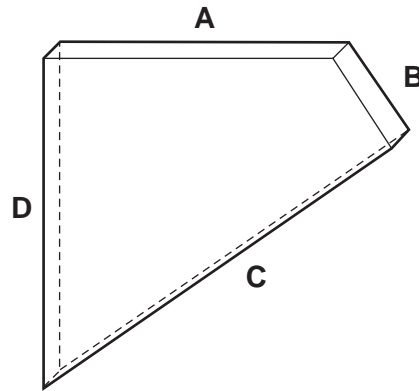

32 Two plastic cups are placed one inside the other. Hot water is poured into the inner cup and a lid is put on top as shown.

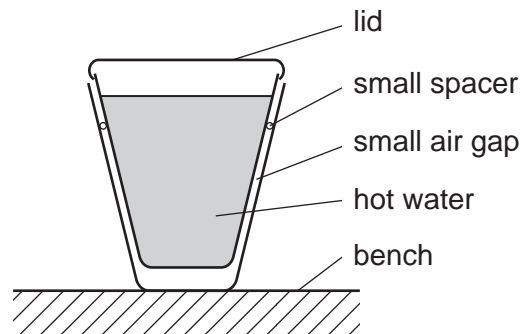

Which statement is correct?

- A Heat loss by radiation is prevented by the small air gap.
 - B No heat passes through the sides of either cup.
 - C The bench is heated by convection from the bottom of the outer cup.
 - D The lid is used to reduce heat loss by convection.
- 33 Which is the best description of the speed of a water wave?
- A the distance between one wave crest and the next
 - B the distance between the crest of a wave and a trough
 - C the distance that a particle of water moves up and down in one second
 - D the distance that a wavefront moves along the surface in one second

34 A ray of light passes through a window.

Which path does it take?

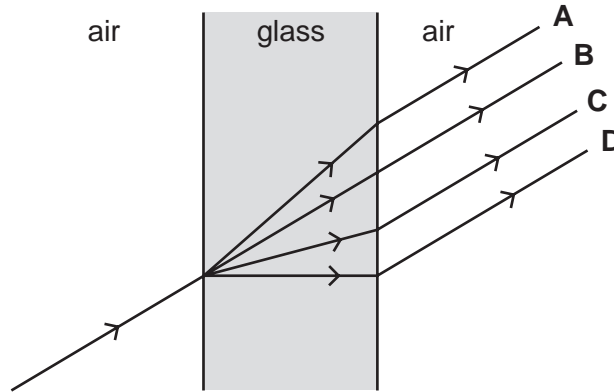

35 Sounds are made by vibrating objects. A certain object vibrates but a person nearby cannot hear any sound.

Which statement might explain why nothing is heard?

- A The amplitude of the sound waves is too large.
- B The frequency of the vibration is too high.
- C The sound waves are transverse.
- D The speed of the sound waves is too high.

36 A student investigates which end of a magnetic compass needle is attracted to a bar magnet.

What does the investigation show?

- A Both ends of the compass needle are attracted by the north pole of the magnet.
- B Both ends of the compass needle are attracted by the south pole of the magnet.
- C One end of the compass needle is attracted by the north pole and the other end by the south pole.
- D The compass needle is not attracted by either end of the magnet.

37 Four lamps and four switches are connected to a power supply as shown in the circuit diagram.

When all the switches are closed, all the lamps are lit.

When one of the switches is then opened, only **one** lamp goes out.

Which switch is opened?

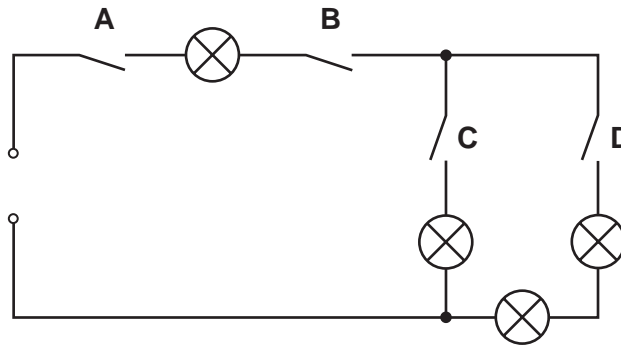

38 An electric power tool is being used outdoors in a shower of rain.

What is the greatest hazard to the user?

- A The cable gets hot and causes burns.
- B The circuit-breaker cuts off the current.
- C The current passes through water and causes a shock.
- D The tool rusts.

39 A Geiger counter detects radiation from radioactive sources.

A radioactive source is inside a thick aluminium container as shown.

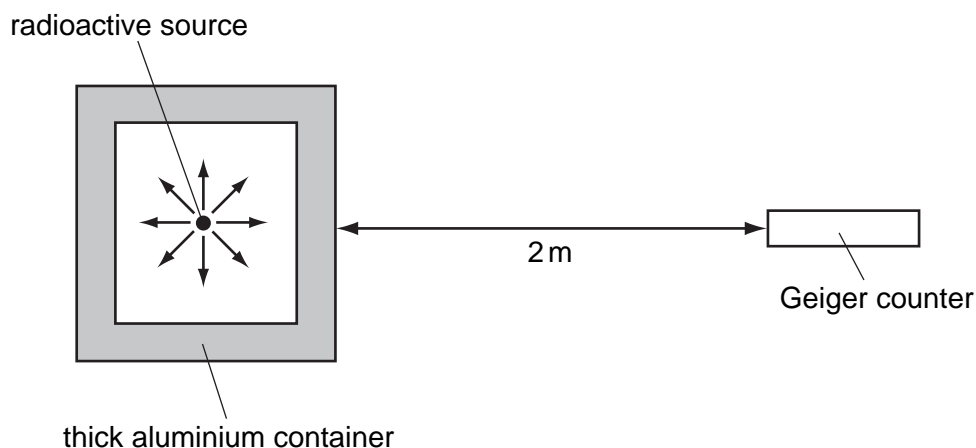

Which type of radiation from this source is being detected?

- A alpha-particles
- B beta-particles
- C gamma-rays
- D radio waves

40 A thermistor is a device whose resistance decreases as its temperature increases.

The table shows the voltage needed at different times during the day to cause a current of 0.02 A in a particular thermistor.

time of day	09:00	12:00	15:00
voltage/V	12.0	6.0	4.0

Which statement describes how the temperature changed during the period 09:00 to 15:00?

- A The temperature decreased throughout this period.
- B The temperature increased throughout this period.
- C The temperature was greatest at 12:00.
- D The temperature was least at 12:00.

BLANK PAGE

