

UNIVERSITY OF CAMBRIDGE INTERNATIONAL EXAMINATIONS  
International General Certificate of Secondary Education

**CO-ORDINATED SCIENCES**

**0654/01**

Paper 1 Multiple Choice

May/June 2004

**45 minutes**

Additional Materials: Multiple Choice Answer Sheet  
Soft clean eraser  
Soft pencil (type B or HB is recommended)

**READ THESE INSTRUCTIONS FIRST**

Write in soft pencil.

Do not use staples, paper clips, highlighters, glue or correction fluid.

Write your name, Centre number and candidate number on the answer sheet in the spaces provided unless this has been done for you.

There are **forty** questions on this paper. Answer **all** questions.

For each question there are four possible answers **A, B, C,** and **D**. Choose the **one** you consider correct and record your choice in **soft pencil** on the separate answer sheet.

**Read the instructions on the answer sheet very carefully.**

Each correct answer will score one mark. A mark will not be deducted for a wrong answer.

Any rough working should be done in this booklet.

A copy of the Periodic Table is printed on page 20.

This document consists of **19** printed pages and **1** blank page.



1 The diagram shows a mammal.

Which feature other than the presence of hair shows that it is a mammal?

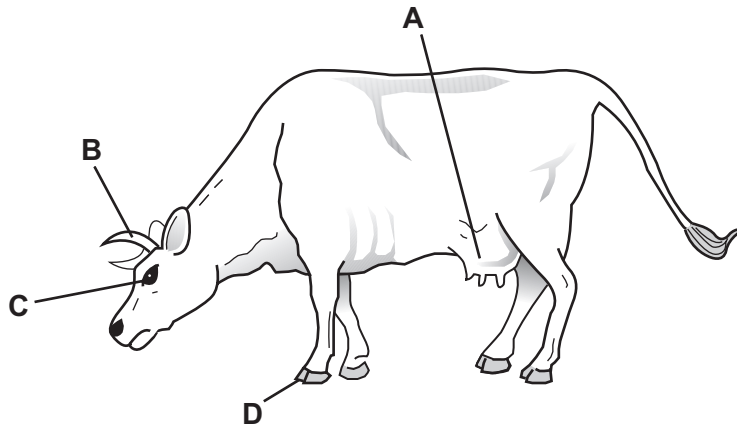

2 The diagram shows a plant cell.

Which structure carries out photosynthesis?

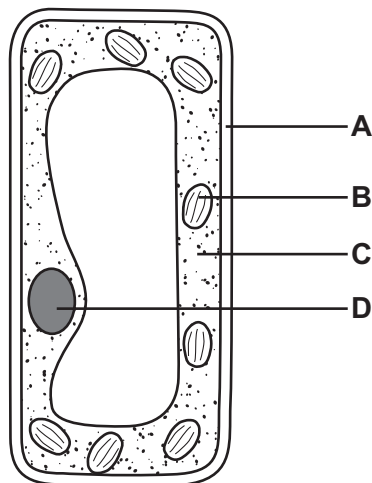

3 What conditions are needed for a plant to have drooping leaves but not a drooping stem?

	enough water	lignin in stem
<b>A</b>	✓	✓
<b>B</b>	✓	x
<b>C</b>	x	✓
<b>D</b>	x	x

4 The diagram shows a cross section of a leaf.

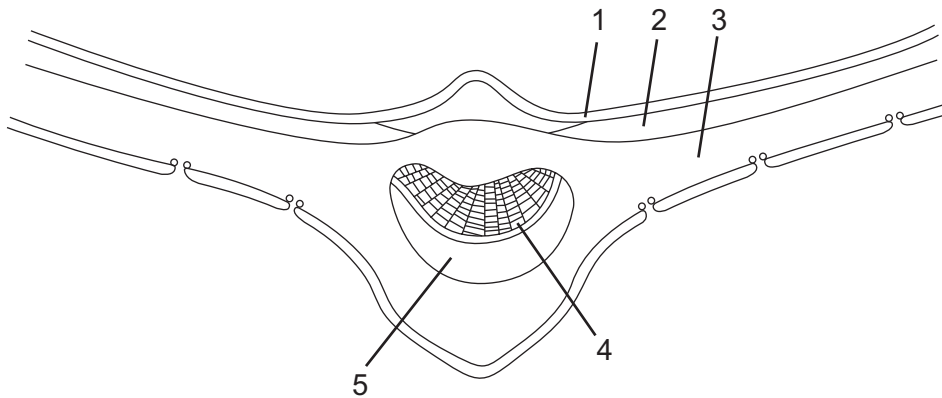

In which two parts of the leaf does photosynthesis take place?

- A** 1 and 3      **B** 2 and 3      **C** 3 and 4      **D** 4 and 5

5 The arrows in the diagram show oxygen in the lungs moving from an alveolus into a blood capillary.

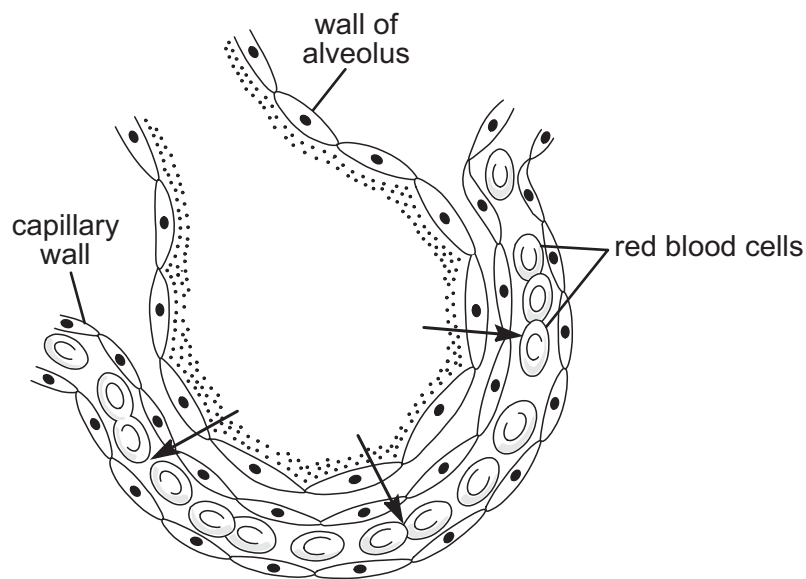

By what process does this movement take place?

- A** breathing  
**B** diffusion  
**C** respiration  
**D** transpiration

6 The diagram shows a section through the human heart.

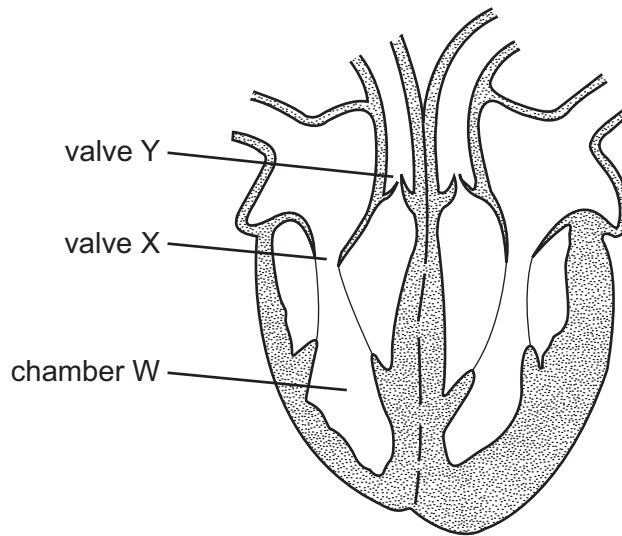

What happens to valves X and Y when blood leaves chamber W?

	X	Y
<b>A</b>	closes	closes
<b>B</b>	closes	opens
<b>C</b>	opens	closes
<b>D</b>	opens	opens

7 The diagram shows part of the lining of the trachea.

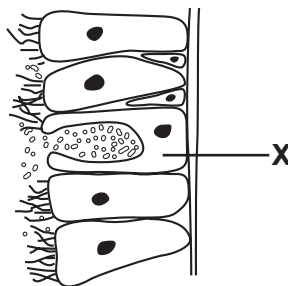

What is **X**?

- A** cartilage
- B** cell of alveolus
- C** cilium
- D** goblet cell

8 Which substance is produced during anaerobic respiration of muscles?

- A amino acid
- B fatty acid
- C glucose
- D lactic acid

9 When farm animals are kept for meat production they are fed a special diet to increase their muscle growth.

Which nutrient is increased in the diet?

- A carbohydrate
- B fat
- C protein
- D vitamins

10 The diagram shows the human alimentary canal.

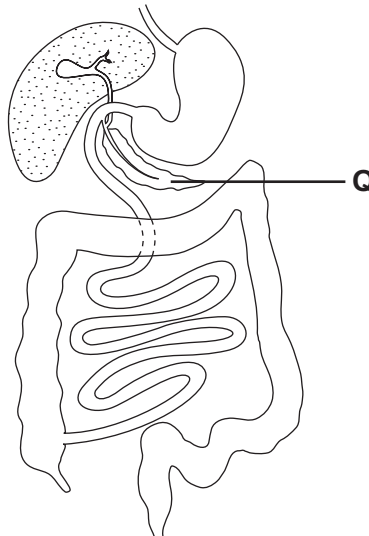

Proteases are produced by structure **Q**.

What is structure **Q** and what nutrient does protease digest?

	structure <b>Q</b>	nutrient digested
<b>A</b>	liver	fat
<b>B</b>	liver	protein
<b>C</b>	pancreas	fat
<b>D</b>	pancreas	protein

- 11 The graph shows the changes that take place in the thickness of the uterus lining during a woman's menstrual cycle.

At which point is menstruation occurring?

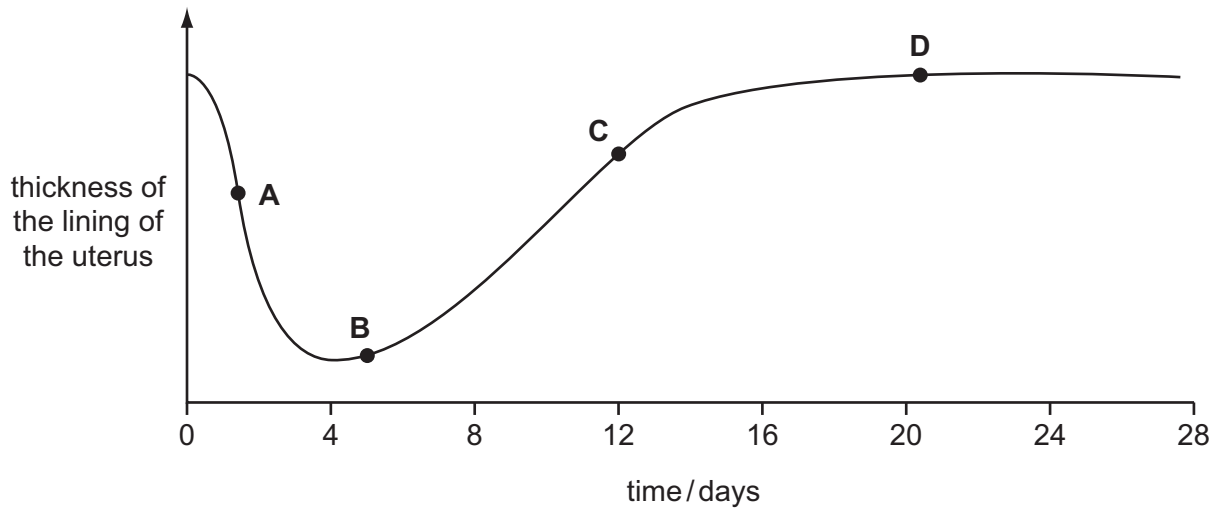

- 12 The diagram shows a section through a flower.

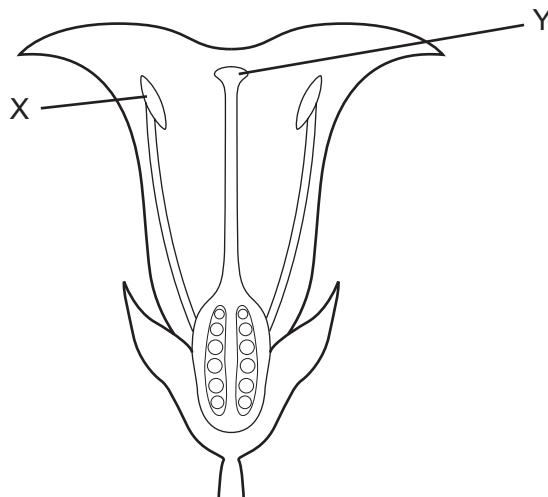

Which process occurs when pollen is transferred from X to Y?

- A dispersal
- B fertilisation
- C pollination
- D reproduction

- 13 In a particular breed of dog, black coat colour is due to a dominant allele, B, and golden colour is due to the recessive allele, b.

A black dog, whose father was golden, is mated with a black bitch whose mother was golden.

What is the likelihood of one of their puppies being heterozygous?

- A nil                      B 1 in 4                      C 1 in 2                      D 1 in 1

- 14 The element phosphorus burns in air, as shown.

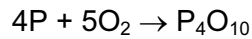

What does the formula  $P_4O_{10}$  show?

- A a mixture of atoms of two elements  
 B a mixture of molecules of two elements  
 C a molecule of a compound  
 D an atom of a compound

- 15 Which particle has the largest mass?

	protons	neutrons	electrons
<b>A</b>	5	6	7
<b>B</b>	6	6	6
<b>C</b>	6	7	7
<b>D</b>	7	7	6

- 16 Which two elements are in the same group of the Periodic Table?

element	number of protons in an atom
1	9
2	10
3	16
4	17

- A 1 and 3                      B 1 and 4                      C 2 and 3                      D 2 and 4





19 When heated, a mineral decomposes.

The gas produced turns limewater milky.

What is the mineral?

- A caliche,  $\text{NaNO}_3$
- B halite,  $\text{NaCl}$
- C limestone,  $\text{CaCO}_3$
- D zinc blende,  $\text{ZnS}$

20 A sample of tap water is tested.

- When boiled, a precipitate forms.
- When dilute nitric acid is added, carbon dioxide is given off.
- When aqueous barium nitrate is added, a white precipitate forms.

What do these tests show about the tap water?

	it is hard	it contains sulphate ions
<b>A</b>	✓	✓
<b>B</b>	✓	x
<b>C</b>	x	✓
<b>D</b>	x	x

21 The pH of water changes when ammonia is bubbled into it.

What happens to the pH and why?

	the pH	ammonia is
<b>A</b>	decreases	acidic
<b>B</b>	decreases	alkaline
<b>C</b>	increases	acidic
<b>D</b>	increases	alkaline

22 The following statement about the test for oxygen is incomplete.

Which words complete gaps 1 and 2?

When a .....1..... splint is placed in oxygen, the splint .....2.....

	1	2
<b>A</b>	burning	relights
<b>B</b>	burning	goes out
<b>C</b>	glowing	relights
<b>D</b>	glowing	goes out

23 The diagram shows a bag of fertiliser.

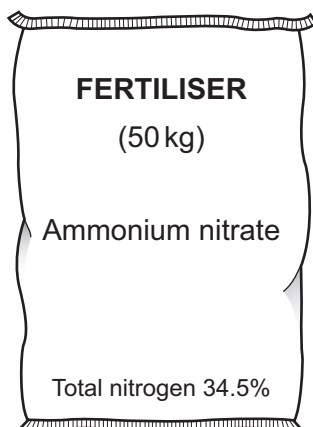

The fertiliser contains nitrogen.

Which other elements are used in fertilisers for healthy plant growth?

- A** carbon and oxygen
- B** carbon and sodium
- C** phosphorus and potassium
- D** potassium and sodium

24 The sentence about chemicals from a natural source is incomplete.

Which words correctly fill the gaps 1 and 2?

The discovery of new .....1..... can result from the study of chemicals present in .....2.....

	1	2
<b>A</b>	alloys	air
<b>B</b>	drugs	plants
<b>C</b>	fertilisers	petroleum
<b>D</b>	proteins	rocks

25 A liquid fuel is burnt in the following experiment.

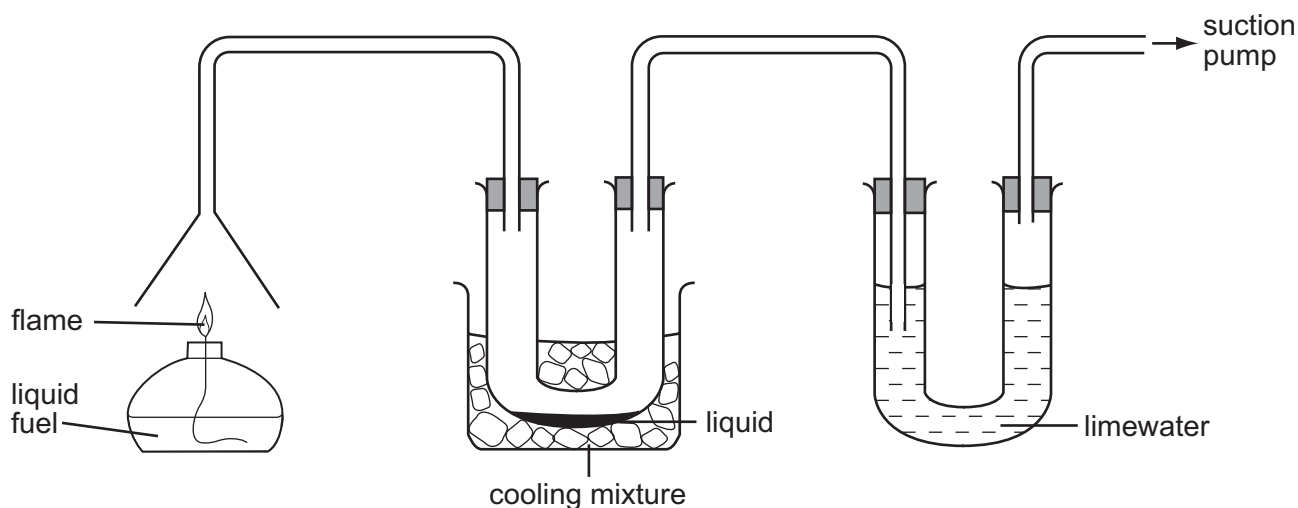

What is being tested for in the gases produced by the burning fuel?

- A** carbon monoxide and carbon dioxide
- B** carbon monoxide and water
- C** carbon dioxide and water
- D** carbon dioxide and sulphur dioxide

26 Which method is used to prevent the girders of a bridge from rusting?

- A** chromium plating
- B** coating with plastic
- C** galvanising
- D** painting

27 Lead has a high density of  $11.3 \text{ g/cm}^3$  and lead(II) iodide is a bright yellow solid.

Which other property of lead explains why it is **not** an example of a transition metal?

- A Lead conducts electricity.
- B Lead forms alloys.
- C Lead melts at  $327^\circ\text{C}$ .
- D Lead(II) oxide is basic.

28 The diagram shows a measuring cylinder.

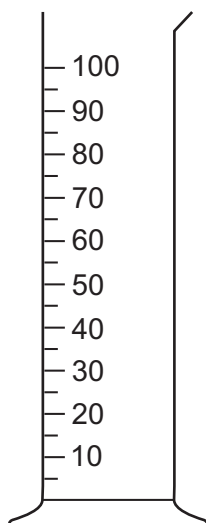

Which unit would be most suitable for its scale?

- A  $\text{mm}^2$
- B  $\text{mm}^3$
- C  $\text{cm}^2$
- D  $\text{cm}^3$

29 The diagram shows the speed-time graph for an object moving at constant speed.

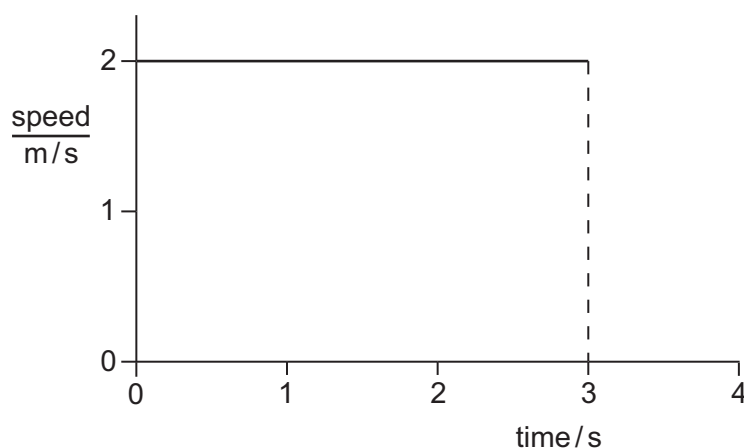

What is the distance travelled by the object in the first 3 s?

- A 1.5 m
- B 2.0 m
- C 3.0 m
- D 6.0 m

30 Which statement about the mass of a falling object is correct?

- A It decreases as the object falls.
- B It is equal to the weight of the object.
- C It is measured in newtons.
- D It stays the same as the object falls.

31 Which of the following is a unit of density?

- A  $\text{cm}^3/\text{g}$
- B  $\text{g}/\text{cm}^2$
- C  $\text{g}/\text{cm}^3$
- D  $\text{kg}/\text{m}^2$

32 An experiment is set up to find out which metal is the best conductor of heat. Balls are stuck with wax to rods made from different metals, as shown in diagram X.

The rods are heated at one end. Some of the balls fall off, leaving some as shown in diagram Y.

Which labelled metal is the best conductor of heat?

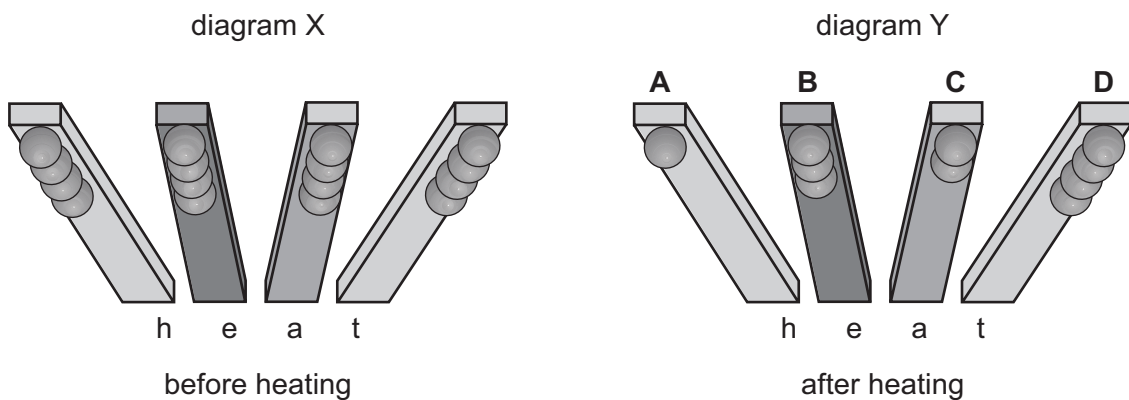

- 33 Thermometer X is held above an ice cube and thermometer Y is held the same distance below the ice cube. After several minutes, the reading on one thermometer changes. The ice cube does not melt.

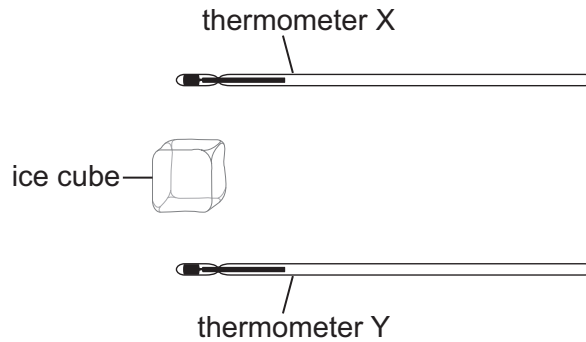

Which thermometer reading changes and why?

	thermometer	reason
<b>A</b>	X	cool air rises from the ice cube
<b>B</b>	X	warm air rises from the ice cube
<b>C</b>	Y	cool air falls from the ice cube
<b>D</b>	Y	warm air falls from the ice cube

34 Three rays of light fall on a converging lens as shown.

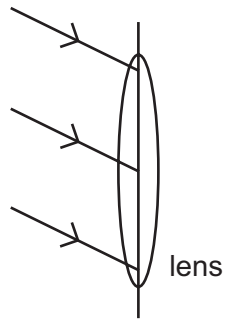

Which diagram shows the path of the rays after passing through the lens?

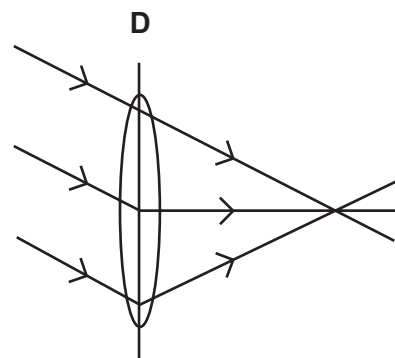
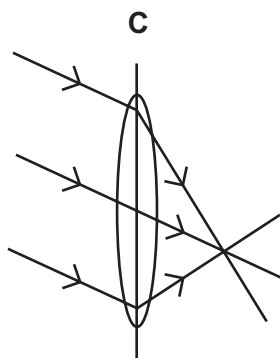
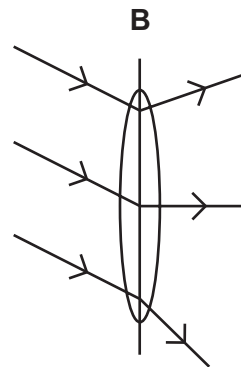
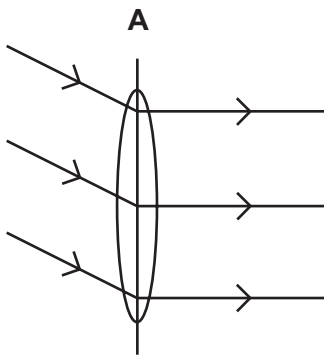

35 The diagram shows a ray of light entering a block of glass.

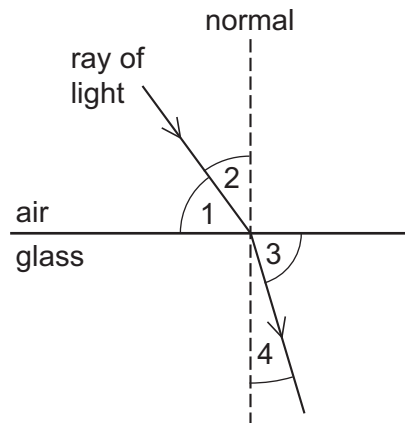

Which numbered angles are the angles of incidence and of refraction?

	angle of incidence	angle of refraction
<b>A</b>	1	3
<b>B</b>	1	4
<b>C</b>	2	3
<b>D</b>	2	4

36 Which circuit shows how a voltmeter is connected to measure the potential difference across the cell?

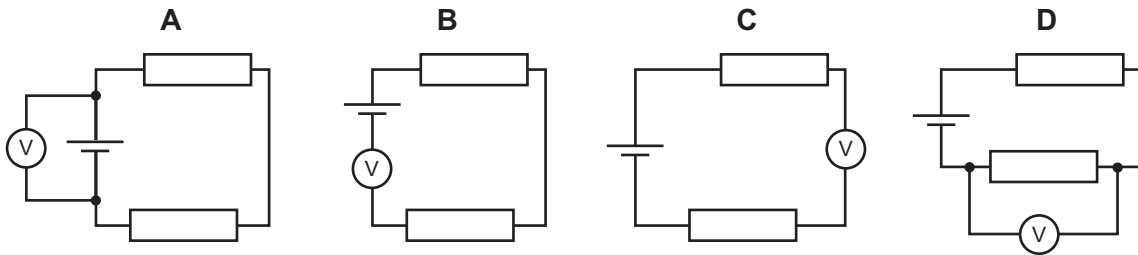



- 37 An electrical component is to be placed in the circuit at Z, to allow the brightness of the lamp to be varied from bright to dim.

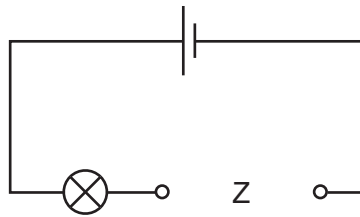

What should be connected at Z?

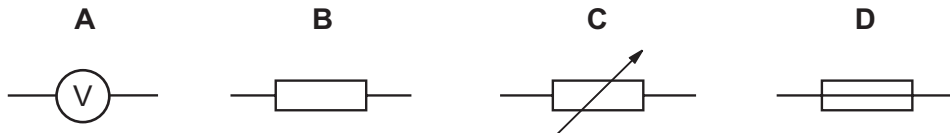

- 38 The circuit shown contains four lamps and three switches.

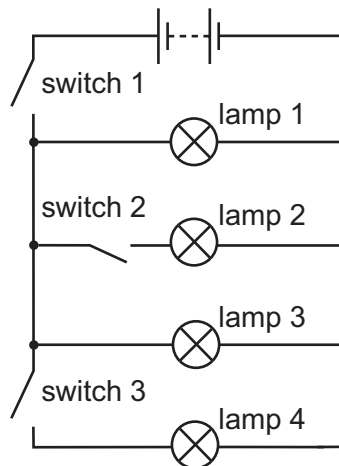

Which switches must be closed to light only lamps 1 and 3?

- A switch 1 only
- B switch 1 and switch 2 only
- C switch 1 and switch 3 only
- D switch 2 and switch 3 only

39 The diagram shows a torch containing two 2 V cells, a switch and a lamp.

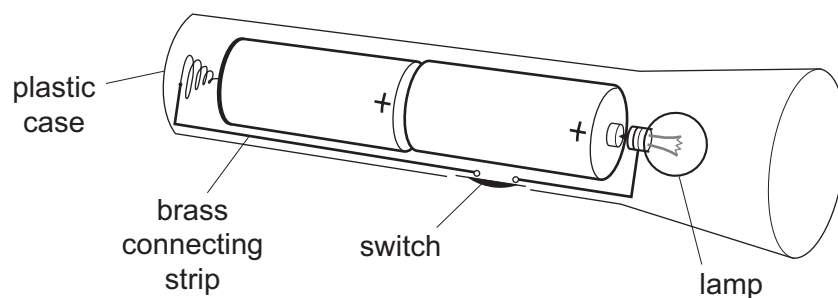

What is the circuit diagram for the torch?

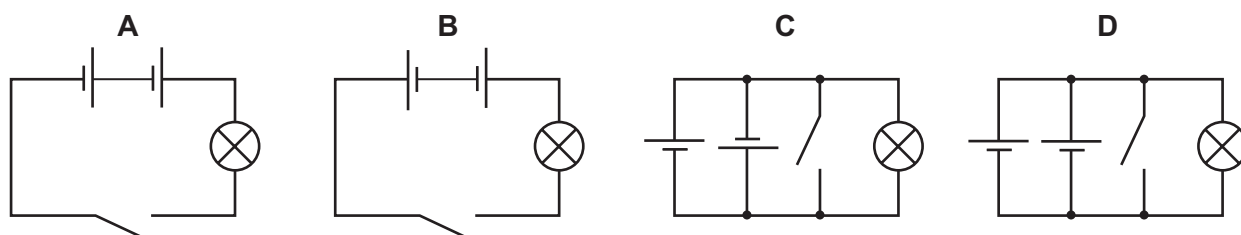

40 Which line correctly describes alpha radiation?

	electric charge	penetrates 1 cm of aluminium?
<b>A</b>	negative	yes
<b>B</b>	negative	no
<b>C</b>	positive	yes
<b>D</b>	positive	no



**DATA SHEET**  
**The Periodic Table of the Elements**

		Group																																			
		I	II	III	IV	V	VI	VII	VIII	IX	X																										
7	3	<b>Li</b> Lithium 4	<b>Be</b> Beryllium 4	<table border="1" style="width: 100%; border-collapse: collapse; text-align: center;"> <tr> <td style="width: 5%;"></td> <td style="width: 5%;"></td> <td style="width: 5%;">1</td> <td style="width: 5%;">2</td> <td style="width: 5%;">3</td> <td style="width: 5%;">4</td> <td style="width: 5%;">5</td> <td style="width: 5%;">6</td> <td style="width: 5%;">7</td> <td style="width: 5%;">8</td> <td style="width: 5%;">9</td> <td style="width: 5%;">10</td> </tr> <tr> <td></td> <td></td> <td><b>H</b> Hydrogen 1</td> <td></td> <td></td> <td></td> <td></td> <td></td> <td></td> <td></td> <td></td> <td></td> </tr> </table>												1	2	3	4	5	6	7	8	9	10			<b>H</b> Hydrogen 1									
		1	2											3	4	5	6	7	8	9	10																
		<b>H</b> Hydrogen 1																																			
23	11	<b>Na</b> Sodium 11	<b>Mg</b> Magnesium 12	<b>B</b> Boron 5	<b>C</b> Carbon 6	<b>N</b> Nitrogen 7	<b>O</b> Oxygen 8	<b>F</b> Fluorine 9	<b>Ne</b> Neon 10																												
39	19	<b>K</b> Potassium 19	<b>Ca</b> Calcium 20	<b>Al</b> Aluminium 13	<b>Si</b> Silicon 14	<b>P</b> Phosphorus 15	<b>S</b> Sulphur 16	<b>Cl</b> Chlorine 17	<b>Ar</b> Argon 18																												
85	37	<b>Rb</b> Rubidium 37	<b>Sr</b> Strontium 38	<b>Ga</b> Gallium 31	<b>Ge</b> Germanium 32	<b>As</b> Arsenic 33	<b>Se</b> Selenium 34	<b>Br</b> Bromine 35	<b>Kr</b> Krypton 36																												
133	55	<b>Cs</b> Caesium 55	<b>Ba</b> Barium 56	<b>Zn</b> Zinc 30	<b>Ga</b> Gallium 31	<b>In</b> Indium 49	<b>Sn</b> Tin 50	<b>Sb</b> Antimony 51	<b>Te</b> Tellurium 52	<b>I</b> Iodine 53	<b>Xe</b> Xenon 54																										
226	87	<b>Fr</b> Francium 87	<b>Ra</b> Radium 88	<b>Co</b> Cobalt 27	<b>Ni</b> Nickel 28	<b>Cu</b> Copper 29	<b>Zn</b> Zinc 30	<b>Ga</b> Gallium 31	<b>Ge</b> Germanium 32	<b>As</b> Arsenic 33	<b>Se</b> Selenium 34																										
227	89	<b>Ac</b> Actinium 89	<b>La</b> Lanthanum 57	<b>Fe</b> Iron 26	<b>Mn</b> Manganese 25	<b>Cr</b> Chromium 24	<b>V</b> Vanadium 23	<b>Ti</b> Titanium 22	<b>Sc</b> Scandium 21	<b>Y</b> Yttrium 39	<b>Zr</b> Zirconium 40																										
227	89	<b>Ac</b> Actinium 89	<b>La</b> Lanthanum 57	<b>Ru</b> Ruthenium 44	<b>Rh</b> Rhodium 45	<b>Pd</b> Palladium 46	<b>Cd</b> Cadmium 48	<b>In</b> Indium 49	<b>Sn</b> Tin 50	<b>Sb</b> Antimony 51	<b>Te</b> Tellurium 52																										
227	89	<b>Ac</b> Actinium 89	<b>La</b> Lanthanum 57	<b>Rh</b> Rhodium 45	<b>Pd</b> Palladium 46	<b>Cd</b> Cadmium 48	<b>In</b> Indium 49	<b>Sn</b> Tin 50	<b>Sb</b> Antimony 51	<b>Te</b> Tellurium 52	<b>Po</b> Polonium 84																										
227	89	<b>Ac</b> Actinium 89	<b>La</b> Lanthanum 57	<b>Os</b> Osmium 76	<b>Ir</b> Iridium 77	<b>Pt</b> Platinum 78	<b>Au</b> Gold 79	<b>Hg</b> Mercury 80	<b>Tl</b> Thallium 81	<b>Pb</b> Lead 82	<b>Bi</b> Bismuth 83																										
227	89	<b>Ac</b> Actinium 89	<b>La</b> Lanthanum 57	<b>Os</b> Osmium 76	<b>Ir</b> Iridium 77	<b>Pt</b> Platinum 78	<b>Au</b> Gold 79	<b>Hg</b> Mercury 80	<b>Tl</b> Thallium 81	<b>Pb</b> Lead 82	<b>Bi</b> Bismuth 83																										
227	89	<b>Ac</b> Actinium 89	<b>La</b> Lanthanum 57	<b>Os</b> Osmium 76	<b>Ir</b> Iridium 77	<b>Pt</b> Platinum 78	<b>Au</b> Gold 79	<b>Hg</b> Mercury 80	<b>Tl</b> Thallium 81	<b>Pb</b> Lead 82	<b>Bi</b> Bismuth 83																										
227	89	<b>Ac</b> Actinium 89	<b>La</b> Lanthanum 57	<b>Os</b> Osmium 76	<b>Ir</b> Iridium 77	<b>Pt</b> Platinum 78	<b>Au</b> Gold 79	<b>Hg</b> Mercury 80	<b>Tl</b> Thallium 81	<b>Pb</b> Lead 82	<b>Bi</b> Bismuth 83																										
227	89	<b>Ac</b> Actinium 89	<b>La</b> Lanthanum 57	<b>Os</b> Osmium 76	<b>Ir</b> Iridium 77	<b>Pt</b> Platinum 78	<b>Au</b> Gold 79	<b>Hg</b> Mercury 80	<b>Tl</b> Thallium 81	<b>Pb</b> Lead 82	<b>Bi</b> Bismuth 83																										
227	89	<b>Ac</b> Actinium 89	<b>La</b> Lanthanum 57	<b>Os</b> Osmium 76	<b>Ir</b> Iridium 77	<b>Pt</b> Platinum 78	<b>Au</b> Gold 79	<b>Hg</b> Mercury 80	<b>Tl</b> Thallium 81	<b>Pb</b> Lead 82	<b>Bi</b> Bismuth 83																										
227	89	<b>Ac</b> Actinium 89	<b>La</b> Lanthanum 57	<b>Os</b> Osmium 76	<b>Ir</b> Iridium 77	<b>Pt</b> Platinum 78	<b>Au</b> Gold 79	<b>Hg</b> Mercury 80	<b>Tl</b> Thallium 81	<b>Pb</b> Lead 82	<b>Bi</b> Bismuth 83																										
227	89	<b>Ac</b> Actinium 89	<b>La</b> Lanthanum 57	<b>Os</b> Osmium 76	<b>Ir</b> Iridium 77	<b>Pt</b> Platinum 78	<b>Au</b> Gold 79	<b>Hg</b> Mercury 80	<b>Tl</b> Thallium 81	<b>Pb</b> Lead 82	<b>Bi</b> Bismuth 83																										
227	89	<b>Ac</b> Actinium 89	<b>La</b> Lanthanum 57	<b>Os</b> Osmium 76	<b>Ir</b> Iridium 77	<b>Pt</b> Platinum 78	<b>Au</b> Gold 79	<b>Hg</b> Mercury 80	<b>Tl</b> Thallium 81	<b>Pb</b> Lead 82	<b>Bi</b> Bismuth 83																										
227	89	<b>Ac</b> Actinium 89	<b>La</b> Lanthanum 57	<b>Os</b> Osmium 76	<b>Ir</b> Iridium 77	<b>Pt</b> Platinum 78	<b>Au</b> Gold 79	<b>Hg</b> Mercury 80	<b>Tl</b> Thallium 81	<b>Pb</b> Lead 82	<b>Bi</b> Bismuth 83																										
227	89	<b>Ac</b> Actinium 89	<b>La</b> Lanthanum 57	<b>Os</b> Osmium 76	<b>Ir</b> Iridium 77	<b>Pt</b> Platinum 78	<b>Au</b> Gold 79	<b>Hg</b> Mercury 80	<b>Tl</b> Thallium 81	<b>Pb</b> Lead 82	<b>Bi</b> Bismuth 83																										
227	89	<b>Ac</b> Actinium 89	<b>La</b> Lanthanum 57	<b>Os</b> Osmium 76	<b>Ir</b> Iridium 77	<b>Pt</b> Platinum 78	<b>Au</b> Gold 79	<b>Hg</b> Mercury 80	<b>Tl</b> Thallium 81	<b>Pb</b> Lead 82	<b>Bi</b> Bismuth 83																										
227	89	<b>Ac</b> Actinium 89	<b>La</b> Lanthanum 57	<b>Os</b> Osmium 76	<b>Ir</b> Iridium 77	<b>Pt</b> Platinum 78	<b>Au</b> Gold 79	<b>Hg</b> Mercury 80	<b>Tl</b> Thallium 81	<b>Pb</b> Lead 82	<b>Bi</b> Bismuth 83																										
227	89	<b>Ac</b> Actinium 89	<b>La</b> Lanthanum 57	<b>Os</b> Osmium 76	<b>Ir</b> Iridium 77	<b>Pt</b> Platinum 78	<b>Au</b> Gold 79	<b>Hg</b> Mercury 80	<b>Tl</b> Thallium 81	<b>Pb</b> Lead 82	<b>Bi</b> Bismuth 83																										
227	89	<b>Ac</b> Actinium 89	<b>La</b> Lanthanum 57	<b>Os</b> Osmium 76	<b>Ir</b> Iridium 77	<b>Pt</b> Platinum 78	<b>Au</b> Gold 79	<b>Hg</b> Mercury 80	<b>Tl</b> Thallium 81	<b>Pb</b> Lead 82	<b>Bi</b> Bismuth 83																										
227	89	<b>Ac</b> Actinium 89	<b>La</b> Lanthanum 57	<b>Os</b> Osmium 76	<b>Ir</b> Iridium 77	<b>Pt</b> Platinum 78	<b>Au</b> Gold 79	<b>Hg</b> Mercury 80	<b>Tl</b> Thallium 81	<b>Pb</b> Lead 82	<b>Bi</b> Bismuth 83																										
227	89	<b>Ac</b> Actinium 89	<b>La</b> Lanthanum 57	<b>Os</b> Osmium 76	<b>Ir</b> Iridium 77	<b>Pt</b> Platinum 78	<b>Au</b> Gold 79	<b>Hg</b> Mercury 80	<b>Tl</b> Thallium 81	<b>Pb</b> Lead 82	<b>Bi</b> Bismuth 83																										
227	89	<b>Ac</b> Actinium 89	<b>La</b> Lanthanum 57	<b>Os</b> Osmium 76	<b>Ir</b> Iridium 77	<b>Pt</b> Platinum 78	<b>Au</b> Gold 79	<b>Hg</b> Mercury 80	<b>Tl</b> Thallium 81	<b>Pb</b> Lead 82	<b>Bi</b> Bismuth 83																										
227	89	<b>Ac</b> Actinium 89	<b>La</b> Lanthanum 57	<b>Os</b> Osmium 76	<b>Ir</b> Iridium 77	<b>Pt</b> Platinum 78	<b>Au</b> Gold 79	<b>Hg</b> Mercury 80	<b>Tl</b> Thallium 81	<b>Pb</b> Lead 82	<b>Bi</b> Bismuth 83																										
227	89	<b>Ac</b> Actinium 89	<b>La</b> Lanthanum 57	<b>Os</b> Osmium 76	<b>Ir</b> Iridium 77	<b>Pt</b> Platinum 78	<b>Au</b> Gold 79	<b>Hg</b> Mercury 80	<b>Tl</b> Thallium 81	<b>Pb</b> Lead 82	<b>Bi</b> Bismuth 83																										
227	89	<b>Ac</b> Actinium 89	<b>La</b> Lanthanum 57	<b>Os</b> Osmium 76	<b>Ir</b> Iridium 77	<b>Pt</b> Platinum 78	<b>Au</b> Gold 79	<b>Hg</b> Mercury 80	<b>Tl</b> Thallium 81	<b>Pb</b> Lead 82	<b>Bi</b> Bismuth 83																										
227	89	<b>Ac</b> Actinium 89	<b>La</b> Lanthanum 57	<b>Os</b> Osmium 76	<b>Ir</b> Iridium 77	<b>Pt</b> Platinum 78	<b>Au</b> Gold 79	<b>Hg</b> Mercury 80	<b>Tl</b> Thallium 81	<b>Pb</b> Lead 82	<b>Bi</b> Bismuth 83																										
227	89	<b>Ac</b> Actinium 89	<b>La</b> Lanthanum 57	<b>Os</b> Osmium 76	<b>Ir</b> Iridium 77	<b>Pt</b> Platinum 78	<b>Au</b> Gold 79	<b>Hg</b> Mercury 80	<b>Tl</b> Thallium 81	<b>Pb</b> Lead 82	<b>Bi</b> Bismuth 83																										
227	89	<b>Ac</b> Actinium 89	<b>La</b> Lanthanum 57	<b>Os</b> Osmium 76	<b>Ir</b> Iridium 77	<b>Pt</b> Platinum 78	<b>Au</b> Gold 79	<b>Hg</b> Mercury 80	<b>Tl</b> Thallium 81	<b>Pb</b> Lead 82	<b>Bi</b> Bismuth 83																										
227	89	<b>Ac</b> Actinium 89	<b>La</b> Lanthanum 57	<b>Os</b> Osmium 76	<b>Ir</b> Iridium 77	<b>Pt</b> Platinum 78	<b>Au</b> Gold 79	<b>Hg</b> Mercury 80	<b>Tl</b> Thallium 81	<b>Pb</b> Lead 82	<b>Bi</b> Bismuth 83																										
227	89	<b>Ac</b> Actinium 89	<b>La</b> Lanthanum 57	<b>Os</b> Osmium 76	<b>Ir</b> Iridium 77	<b>Pt</b> Platinum 78	<b>Au</b> Gold 79	<b>Hg</b> Mercury 80	<b>Tl</b> Thallium 81	<b>Pb</b> Lead 82	<b>Bi</b> Bismuth 83																										
227	89	<b>Ac</b> Actinium 89	<b>La</b> Lanthanum 57	<b>Os</b> Osmium 76	<b>Ir</b> Iridium 77	<b>Pt</b> Platinum 78	<b>Au</b> Gold 79	<b>Hg</b> Mercury 80	<b>Tl</b> Thallium 81	<b>Pb</b> Lead 82	<b>Bi</b> Bismuth 83																										
227	89	<b>Ac</b> Actinium 89	<b>La</b> Lanthanum 57	<b>Os</b> Osmium 76	<b>Ir</b> Iridium 77	<b>Pt</b> Platinum 78	<b>Au</b> Gold 79	<b>Hg</b> Mercury 80	<b>Tl</b> Thallium 81	<b>Pb</b> Lead 82	<b>Bi</b> Bismuth 83																										
227	89	<b>Ac</b> Actinium 89	<b>La</b> Lanthanum 57	<b>Os</b> Osmium 76	<b>Ir</b> Iridium 77	<b>Pt</b> Platinum 78	<b>Au</b> Gold 79	<b>Hg</b> Mercury 80	<b>Tl</b> Thallium 81	<b>Pb</b> Lead 82	<b>Bi</b> Bismuth 83																										
227	89	<b>Ac</b> Actinium 89	<b>La</b> Lanthanum 57	<b>Os</b> Osmium 76	<b>Ir</b> Iridium 77	<b>Pt</b> Platinum 78	<b>Au</b> Gold 79	<b>Hg</b> Mercury 80	<b>Tl</b> Thallium 81	<b>Pb</b> Lead 82	<b>Bi</b> Bismuth 83																										
227	89	<b>Ac</b> Actinium 89	<b>La</b> Lanthanum 57	<b>Os</b> Osmium 76	<b>Ir</b> Iridium 77	<b>Pt</b> Platinum 78	<b>Au</b> Gold 79	<b>Hg</b> Mercury 80	<b>Tl</b> Thallium 81	<b>Pb</b> Lead 82	<b>Bi</b> Bismuth 83																										
227	89	<b>Ac</b> Actinium 89	<b>La</b> Lanthanum 57	<b>Os</b> Osmium 76	<b>Ir</b> Iridium 77	<b>Pt</b> Platinum 78	<b>Au</b> Gold 79	<b>Hg</b> Mercury 80	<b>Tl</b> Thallium 81	<b>Pb</b> Lead 82	<b>Bi</b> Bismuth 83																										
227	89	<b>Ac</b> Actinium 89	<b>La</b> Lanthanum 57	<b>Os</b> Osmium 76	<b>Ir</b> Iridium 77	<b>Pt</b> Platinum 78	<b>Au</b> Gold 79	<b>Hg</b> Mercury 80	<b>Tl</b> Thallium 81	<b>Pb</b> Lead 82	<b>Bi</b> Bismuth 83																										
227	89	<b>Ac</b> Actinium 89	<b>La</b> Lanthanum 57	<b>Os</b> Osmium 76	<b>Ir</b> Iridium 77	<b>Pt</b> Platinum 78	<b>Au</b> Gold 79	<b>Hg</b> Mercury 80	<b>Tl</b> Thallium 81	<b>Pb</b> Lead 82	<b>Bi</b> Bismuth 83																										
227	89	<b>Ac</b> Actinium 89	<b>La</b> Lanthanum 57	<b>Os</b> Osmium 76	<b>Ir</b> Iridium 77	<b>Pt</b> Platinum 78	<b>Au</b> Gold 79	<b>Hg</b> Mercury 80	<b>Tl</b> Thallium 81	<b>Pb</b> Lead 82	<b>Bi</b> Bismuth 83																										
227	89	<b>Ac</b> Actinium 89	<b>La</b> Lanthanum 57	<b>Os</b> Osmium 76	<b>Ir</b> Iridium 77	<b>Pt</b> Platinum 78	<b>Au</b> Gold 79	<b>Hg</b> Mercury 80	<b>Tl</b> Thallium 81	<b>Pb</b> Lead 82	<b>Bi</b> Bismuth 83																										
227	89	<b>Ac</b> Actinium 89	<b>La</b> Lanthanum 57	<b>Os</b> Osmium 76	<b>Ir</b> Iridium 77	<b>Pt</b> Platinum 78	<b>Au</b> Gold 79	<b>Hg</b> Mercury 80	<b>Tl</b> Thallium 81	<b>Pb</b> Lead 82	<b>Bi</b> Bismuth 83																										
227	89	<b>Ac</b> Actinium 89	<b>La</b> Lanthanum 57	<b>Os</b> Osmium 76	<b>Ir</b> Iridium 77	<b>Pt</b> Platinum 78	<b>Au</b> Gold 79	<b>Hg</b> Mercury 80	<b>Tl</b> Thallium 81	<b>Pb</b> Lead 82	<b>Bi</b> Bismuth 83																										
227	89	<b>Ac</b> Actinium 89	<b>La</b> Lanthanum 57	<b>Os</b> Osmium 76	<b>Ir</b> Iridium 77	<b>Pt</b> Platinum 78	<b>Au</b> Gold 79	<b>Hg</b> Mercury 80	<b>Tl</b> Thallium 81	<b>Pb</b> Lead 82	<b>Bi</b> Bismuth 83																										
227	89	<b>Ac</b> Actinium 89	<b>La</b> Lanthanum 57	<b>Os</b> Osmium 76	<b>Ir</b> Iridium 77	<b>Pt</b> Platinum 78	<b>Au</b> Gold 79	<b>Hg</b> Mercury 80	<b>Tl</b> Thallium 81	<b>Pb</b> Lead 82	<b>Bi</b> Bismuth 83																										
227	89	<b>Ac</b> Actinium 89	<b>La</b> Lanthanum 57	<b>Os</b> Osmium 76	<b>Ir</b> Iridium 77	<b>Pt</b> Platinum 78	<b>Au</b> Gold 79	<b>Hg</b> Mercury 80	<b>Tl</b> Thallium 81	<b>Pb</b> Lead 82	<b>Bi</b> Bismuth 83																										
227</																																					