



UNIVERSITY OF CAMBRIDGE INTERNATIONAL EXAMINATIONS
International General Certificate of Secondary Education

COMBINED SCIENCE

0653/12

Paper 1 Multiple Choice

October/November 2013

45 minutes

Additional Materials: Multiple Choice Answer Sheet
Soft clean eraser
Soft pencil (type B or HB is recommended)

* 0 4 7 5 6 5 3 4 6 4 *

READ THESE INSTRUCTIONS FIRST

Write in soft pencil.

Do not use staples, paper clips, highlighters, glue or correction fluid.

Write your name, Centre number and candidate number on the Answer Sheet in the spaces provided unless this has been done for you.

DO NOT WRITE IN ANY BARCODES.

There are **forty** questions on this paper. Answer **all** questions. For each question there are four possible answers **A, B, C** and **D**.

Choose the **one** you consider correct and record your choice in **soft pencil** on the separate Answer Sheet.

Read the instructions on the Answer Sheet very carefully.

Each correct answer will score one mark. A mark will not be deducted for a wrong answer.

Any rough working should be done in this booklet.

A copy of the Periodic Table is printed on page 20.

Electronic calculators may be used.

This document consists of **18** printed pages and **2** blank pages.



- 1 The plant cell in the diagram has a width of 30 mm when it is magnified by a microscope (magnification shown in brackets).

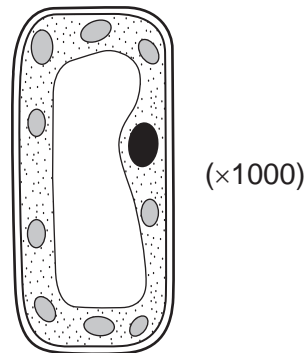

What is the actual width of the cell?

- A 0.003 mm B 0.03 mm C 0.3 mm D 30 mm
- 2 The diagram shows a leaf in sunlight and some of the substances that diffuse into and out of it.

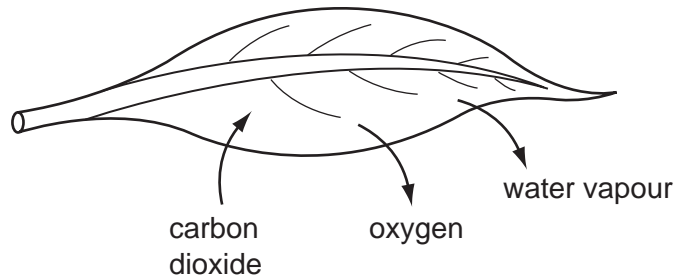

Which of the following has a higher concentration outside the leaf than inside the leaf?

- A carbon dioxide only
 B carbon dioxide and oxygen
 C oxygen and water vapour
 D water vapour only

- 3 The diagram shows how the activity of an enzyme changes with temperature.

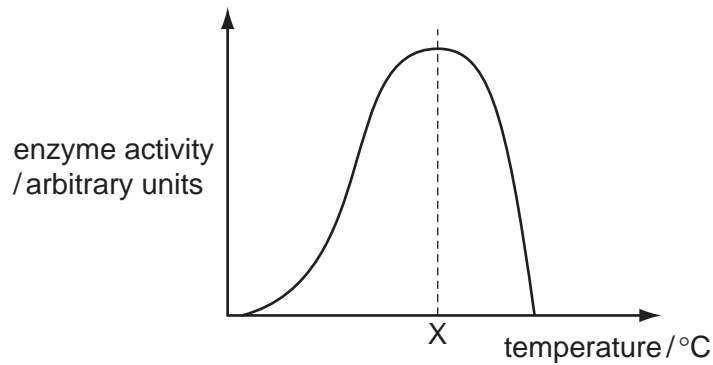

This enzyme works in the human body.

What is the most likely value of temperature X?

- A 10°C B 40°C C 70°C D 100°C
- 4 What must be present for photosynthesis to occur?

	chlorophyll	light	oxygen	water
A	✓	✓	✓	✓
B	✓	✓	x	✓
C	x	✓	✓	x
D	x	x	x	✓

key

✓ = is necessary

x = not necessary

- 5 The diagram shows a section through a human tooth.

Which part is made of the hardest material?

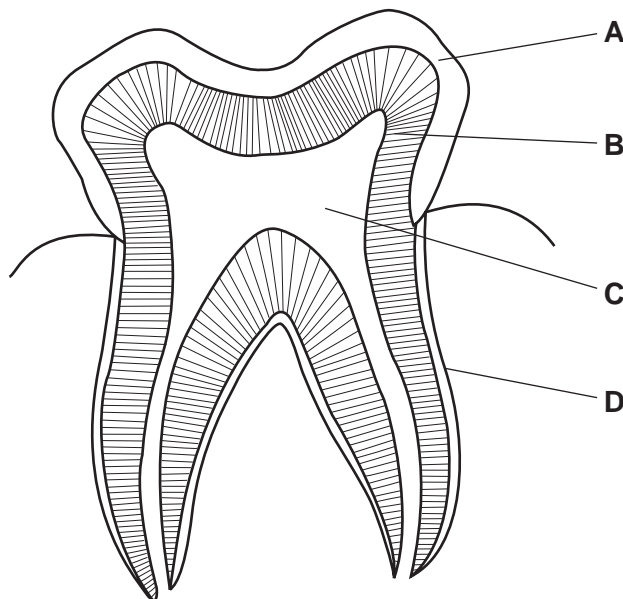

6 Which word equation represents aerobic respiration?

- A carbon dioxide + water → glucose
- B carbon dioxide + water → glucose + oxygen
- C glucose → carbon dioxide + water
- D glucose + oxygen → carbon dioxide + water

7 The diagram shows a section through the human heart.

Which structure is the tricuspid valve?

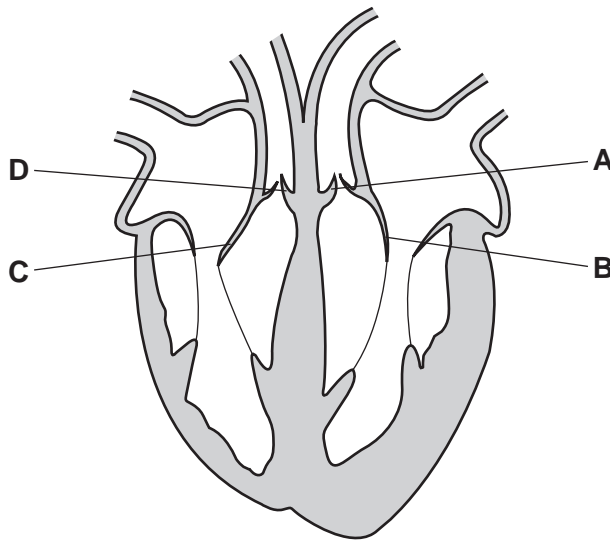

8 A healthy plant has been in the light. A leaf is taken from it, decolourised and then tested with iodine solution.

What colour does the iodine solution become?

- A black
- B brick red
- C green
- D pale blue

9 The diagrams show shoots of maize seedlings.

Which shoot shows a geotropic response in which it grows away from the stimulus?

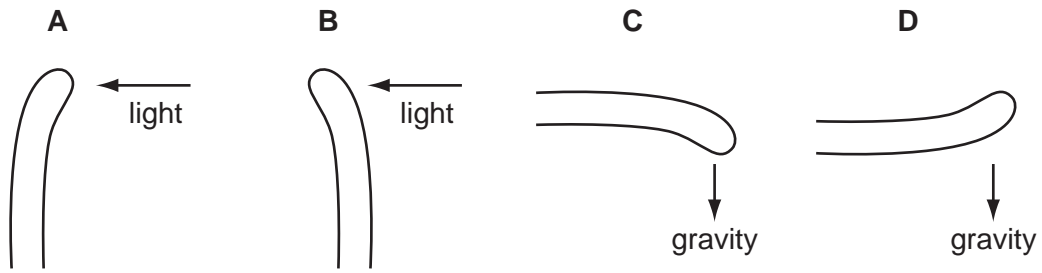

10 The diagram shows a section through a flower.

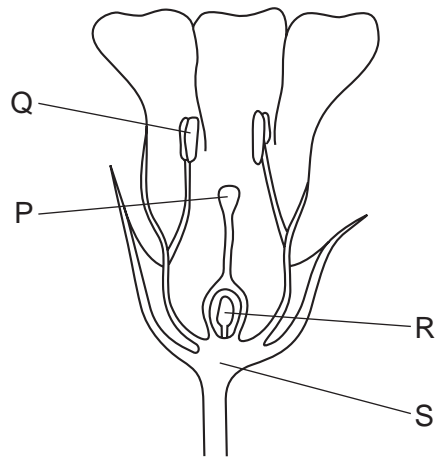

In which parts of the flower are pollen grains produced and received?

	pollen grains produced	pollen grains received
A	P	S
B	Q	P
C	R	Q
D	S	R

11 How often is an egg usually released from the ovaries of a woman?

- A** once a week
- B** once every 14 days
- C** once every 28 days
- D** once every 9 months

12 The diagram shows part of the carbon cycle.

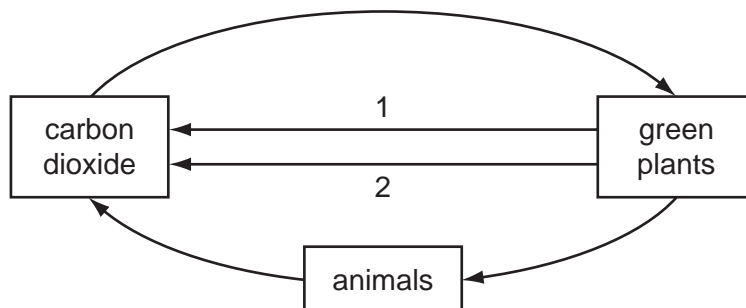

What are processes 1 and 2?

- A decomposition and respiration
 - B feeding and photosynthesis
 - C photosynthesis and decomposition
 - D respiration and feeding
- 13 What is the effect of cutting down large numbers of trees?
- A Flooding is less likely to occur.
 - B It increases the amount of carbon dioxide in the air.
 - C It increases the amount of methane in the air.
 - D It prevents the extinction of animal species.
- 14 Which method of separation can be used to obtain pure water from aqueous potassium chloride?
- A chromatography
 - B crystallisation
 - C distillation
 - D filtration
- 15 Which reaction involves combustion?
- A calcium carbonate \rightarrow calcium oxide + carbon dioxide
 - B methane + oxygen \rightarrow carbon dioxide + water
 - C sodium carbonate + hydrochloric acid \rightarrow sodium chloride + water + carbon dioxide
 - D sodium hydroxide + hydrochloric acid \rightarrow sodium chloride + water

16 Marble and chalk are two forms of calcium carbonate.

The diagram shows equal masses of lumps of marble and powdered chalk placed in dilute hydrochloric acid.

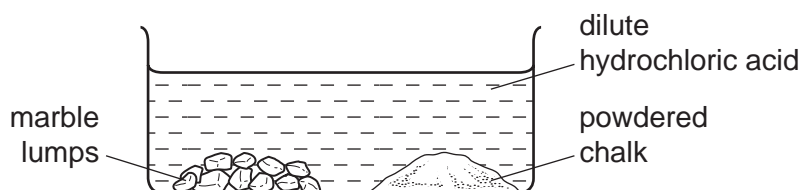

The marble takes longer than the chalk to dissolve in the acid.

Why is this?

- A Marble is more reactive than chalk.
- B Marble is more soluble than chalk.
- C The marble has the smaller surface area.
- D The marble is more basic.

17 In which test-tube does rusting occur most quickly?

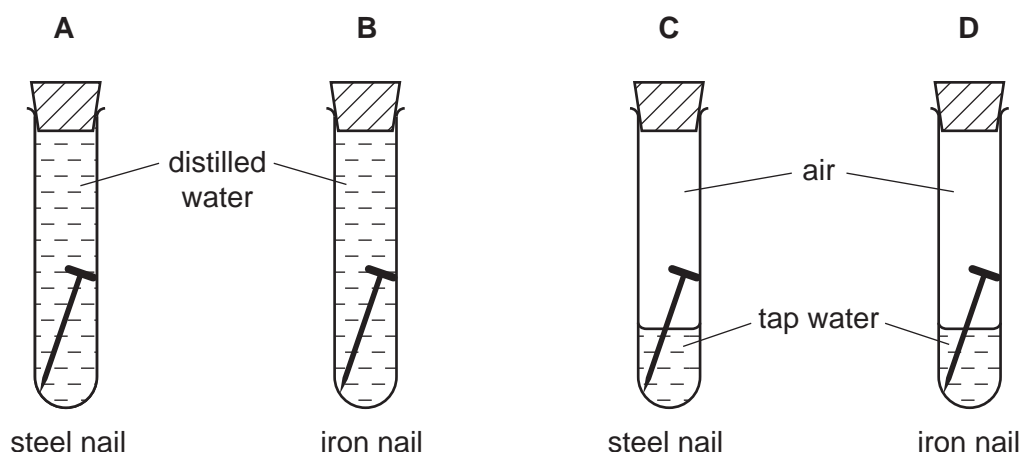

18 The table shows the properties of four substances.

Which substance is an alkali?

	solubility in water	reaction with an acid
A	insoluble	reacts
B	insoluble	does not react
C	soluble	reacts
D	soluble	does not react

19 The positions of elements P, Q, R, S and T in the Periodic Table are shown.

The letters are not the symbols for the elements.

	I	II															III	IV	V	VI	VII	0
	P	Q																			R	S
	T																					

Which element forms an ionic compound with element P?

A Q

B R

C S

D T

20 In the diagrams below, ● and ○ represent different atoms.

Which diagram represents molecules of a single compound?

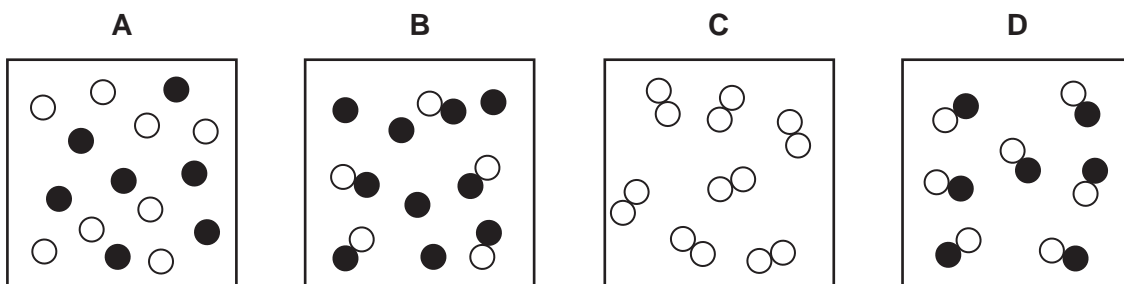

21 Molecules of W, X and Y are shown.

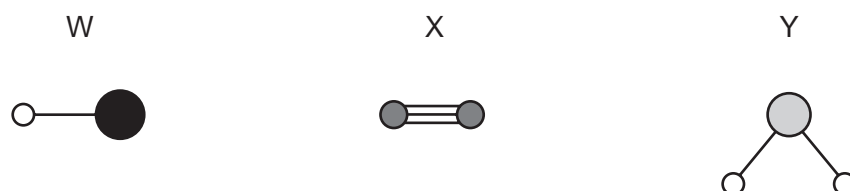

What are W, X and Y?

	W	X	Y
A	hydrogen chloride	nitrogen	water
B	hydrogen chloride	water	nitrogen
C	nitrogen	hydrogen chloride	water
D	water	nitrogen	hydrogen chloride

22 Copper(II) bromide can be electrolysed in the same way as copper(II) chloride.

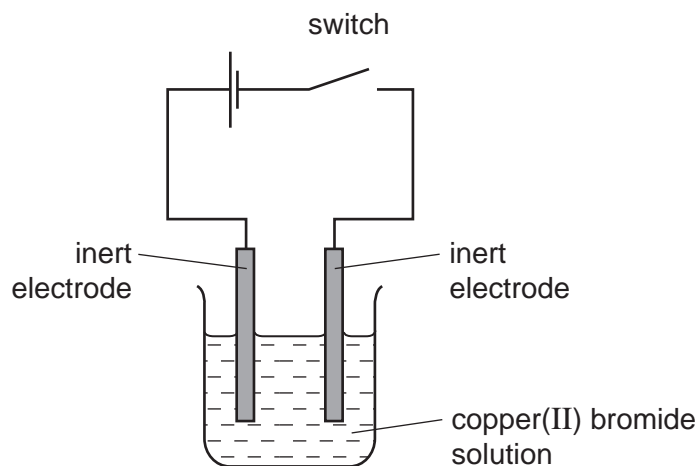

Which row in the table correctly describes the products at the electrodes?

	product at anode	product at cathode
A	brown liquid	brown-red solid
B	brown-red solid	brown liquid
C	colourless gas	brown-red solid
D	silvery solid	colourless gas

23 Metal X reacts rapidly with cold water.

Metal Y does not react with dilute hydrochloric acid.

Metal Y is obtained from its oxide by heating with carbon.

Which row shows the more reactive metal and the type of reaction which metal Y oxide undergoes when it is heated with carbon?

	more reactive metal	type of reaction
A	X	oxidation
B	X	reduction
C	Y	oxidation
D	Y	reduction

- 24 80 cm^3 of dry air is passed over hot copper until there is no further change in volume.

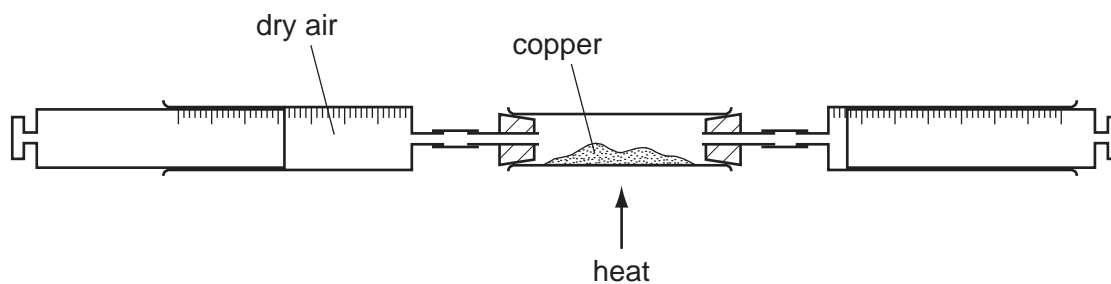

The volume of air decreases by 16 cm^3 .

Which gas reacts with the copper?

- A carbon dioxide
 - B nitrogen
 - C oxygen
 - D water vapour
- 25 The diagram shows what happens when two metals are added to water.

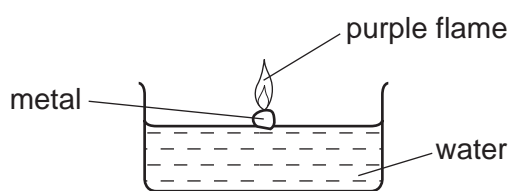

experiment 1

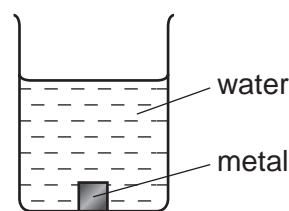

experiment 2

What are the metals?

	experiment 1	experiment 2
A	calcium	zinc
B	magnesium	copper
C	potassium	calcium
D	potassium	copper

26 The diagram shows a molecule of a compound of silicon and hydrogen.

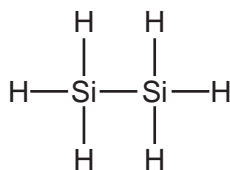

What is the molecular formula of this compound?

- A** SiH_3 **B** SiH_4 **C** Si_2H_6 **D** Si_6H_2

27 A catalyst is a substance that1..... a reaction and is2..... at the end of the reaction.

Which words correctly complete gaps 1 and 2?

	1	2
A	slows down	changed
B	slows down	unchanged
C	speeds up	changed
D	speeds up	unchanged

28 The speed/time graph for a car journey is shown.

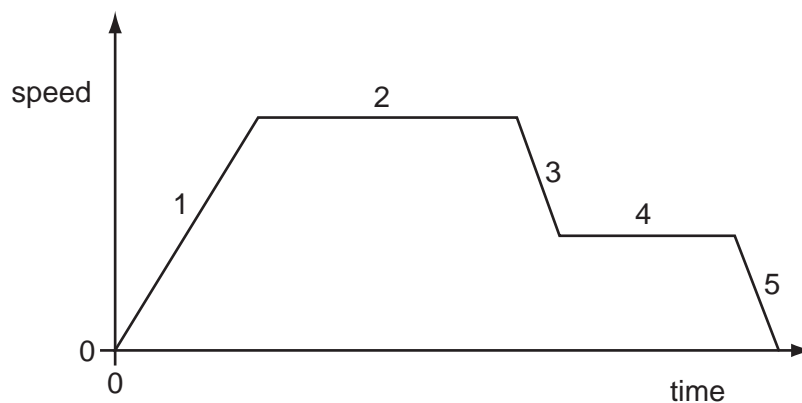

During which two parts of the journey is the car moving at constant speed?

- A** 1 and 3 **B** 1 and 5 **C** 2 and 4 **D** 3 and 5

29 The diagram shows two cubes of different sizes made from the same substance.

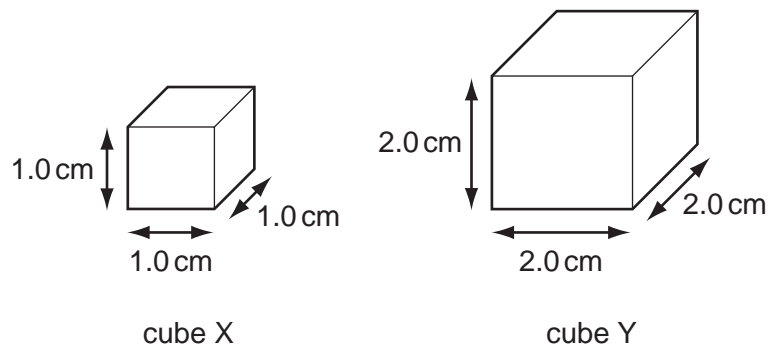

Cube X has a density of 1.2 g/cm^3 .

What is the density of cube Y?

- A** 1.2 g/cm^3 **B** 2.4 g/cm^3 **C** 4.8 g/cm^3 **D** 9.6 g/cm^3

30 Weight lifting involves a number of different stages.

In which stage is **no** work being done on the weights?

A



The weights are lifted from the floor to the chest.

B

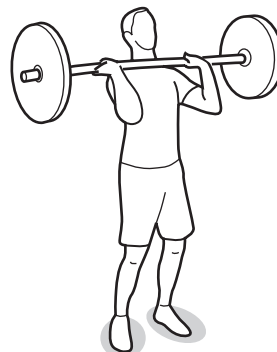

The weights are raised as the lifter stands up.

C



The weights are lifted above the head.

D



The weights are held stationary above the head.

31 A drop of liquid falls on a student's skin and evaporates quickly.

What is the effect on the skin and the reason for this effect?

- A** The skin cools because the most energetic molecules escape from the liquid.
- B** The skin cools because the most energetic molecules remain in the liquid.
- C** The skin warms because the most energetic molecules escape from the liquid.
- D** The skin warms because the most energetic molecules remain in the liquid.

32 Benzene and glycerine are two substances.

The table gives the melting point and the boiling point of benzene and of glycerine.

	melting point	boiling point
benzene	5.4 °C	80 °C
glycerine	18 °C	290 °C

At which temperature will both benzene and glycerine be liquid?

- A 0 °C B 50 °C C 100 °C D 150 °C

33 The diagrams show four identical pieces of ice that are heated in test-tubes of water. All four burners provide heat at the same rate.

In which test-tube does the ice take the longest time to melt?

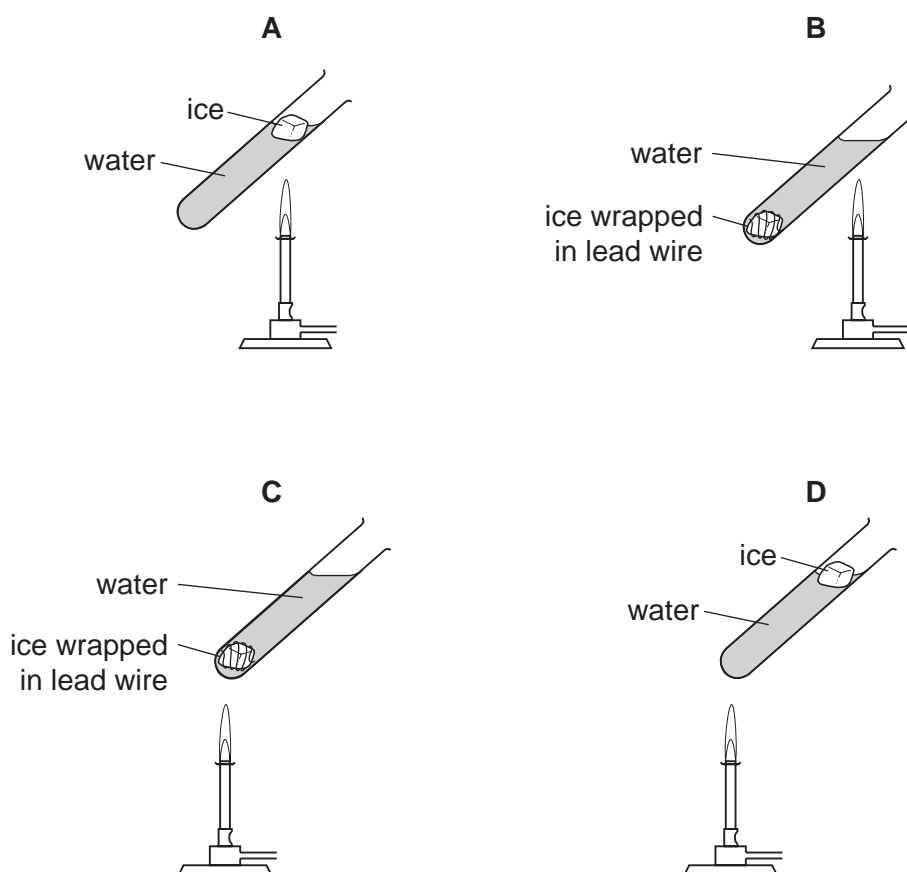

34 The diagram shows a rope with one end fixed to a wall.

The end of the rope is moved up and down through a distance of 0.50 m twice every second.

This makes a wave move along the rope.

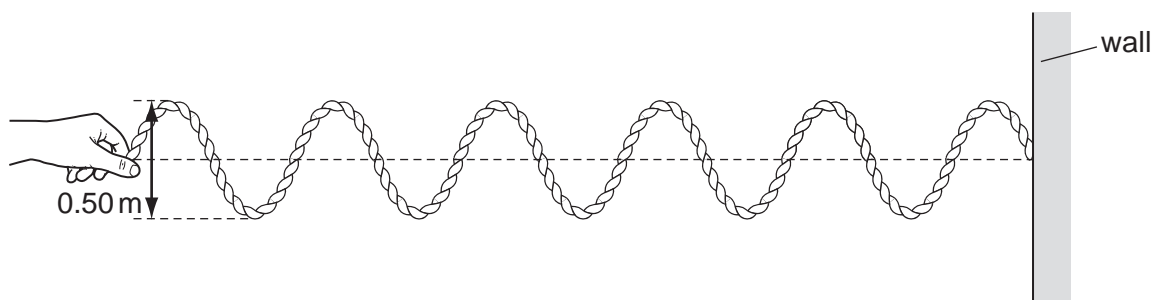

Which line in the table shows the amplitude and the frequency of the wave?

	amplitude / m	frequency / Hz
A	0.25	0.50
B	0.25	2.0
C	0.50	0.50
D	0.50	2.0

35 A ray of light travels from glass into air. The angle of refraction is equal to the angle of incidence.

What is the angle of incidence?

- A** 0° **B** 45° **C** 60° **D** 90°

36 Which electromagnetic waves are found immediately either side of the visible region of the electromagnetic spectrum?

- A** infrared and ultra-violet
B microwaves and infrared
C microwaves and X-rays
D ultra-violet and X-rays

- 37 Two sound waves P and Q are displayed on an oscilloscope. The settings on the oscilloscope are the same for P and Q.

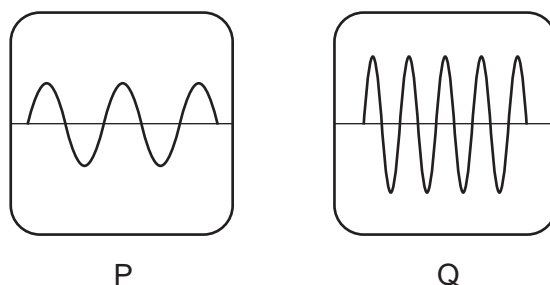

Which statement correctly compares the pitch and the loudness of the two sounds?

- A P has a higher pitch and is louder than Q.
 - B P has a higher pitch and is quieter than Q.
 - C P has a lower pitch and is louder than Q.
 - D P has a lower pitch and is quieter than Q.
- 38 There is an electric current in the circuit shown.

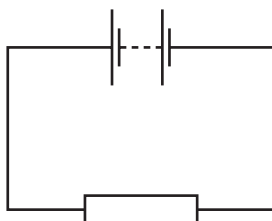

Which two changes will each increase the current?

	change 1	change 2
A	decrease the voltage of the battery	decrease the resistance of the resistor
B	decrease the voltage of the battery	increase the resistance of the resistor
C	increase the voltage of the battery	decrease the resistance of the resistor
D	increase the voltage of the battery	increase the resistance of the resistor

- 39 The charger for a laptop computer is connected by a cable to the mains supply through a plug. The plug contains a 13 A fuse. The thin wires in the cable are designed to carry a current of 2 A. A fault develops and the current in the wires rises to 5 A.

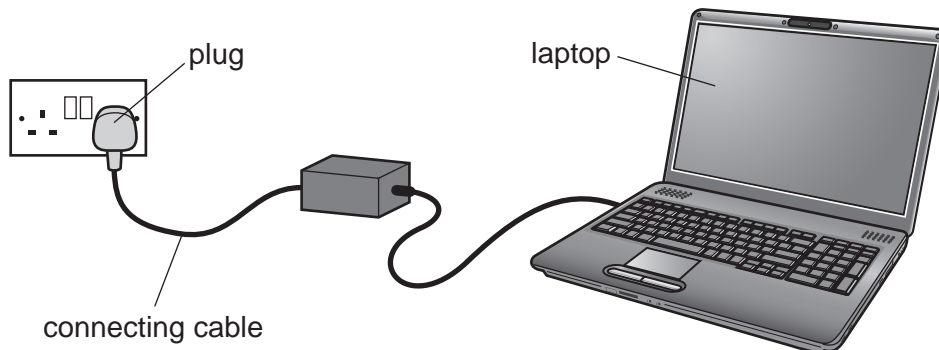

What is the danger caused by this larger current?

- A A large amount of electrical energy could be wasted.
- B Somebody might receive an electric shock.
- C The fuse could blow and start a fire.
- D The wires could overheat and start a fire.

- 40 The circuit shown contains four labelled switches.

All the switches are closed.

Which switch can be opened without changing the brightness of either bulb?

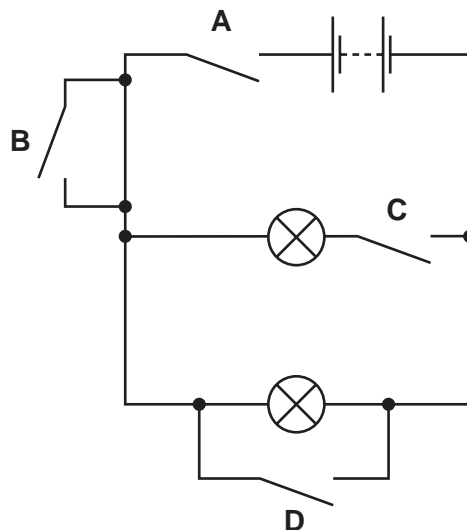

DATA SHEET
The Periodic Table of the Elements

		Group																																			
		I	II	III	IV	V	VI	VII	VIII	IX	X	0																									
		1 H Hydrogen 1											4 He Helium 2																								
7 Li Lithium 3	9 Be Beryllium 4											11 B Boron 5	12 C Carbon 6	14 N Nitrogen 7	16 O Oxygen 8	17 F Fluorine 9	18 Ne Neon 10																				
23 Na Sodium 11	24 Mg Magnesium 12											27 Al Aluminium 13	28 Si Silicon 14	31 P Phosphorus 15	32 S Sulfur 16	35.5 Cl Chlorine 17	40 Ar Argon 18																				
39 K Potassium 19	40 Ca Calcium 20	45 Sc Scandium 21	48 Ti Titanium 22	51 V Vanadium 23	52 Cr Chromium 24	55 Mn Manganese 25	56 Fe Iron 26	59 Co Cobalt 27	59 Ni Nickel 28	64 Cu Copper 29	65 Zn Zinc 30	70 Ga Gallium 31	73 Ge Germanium 32	75 As Arsenic 33	79 Se Selenium 34	80 Br Bromine 35	84 Kr Krypton 36																				
85 Rb Rubidium 37	88 Sr Strontium 38	89 Y Yttrium 39	91 Zr Zirconium 40	93 Nb Niobium 41	96 Mo Molybdenum 42	101 Ru Ruthenium 44	101 Rh Rhodium 45	106 Pd Palladium 46	108 Ag Silver 47	112 Cd Cadmium 48	115 In Indium 49	119 Sn Tin 50	122 Sb Antimony 51	128 Te Tellurium 52	127 I Iodine 53	131 Xe Xenon 54	133 Cs Caesium 55	137 Ba Barium 56	139 La Lanthanum 57	178 Hf Hafnium 72	181 Ta Tantalum 73	184 W Tungsten 74	190 Os Osmium 76	192 Ir Iridium 77	195 Pt Platinum 78	197 Au Gold 79	201 Hg Mercury 80	204 Tl Thallium 81	207 Pb Lead 82	209 Bi Bismuth 83	210 Po Polonium 84	210 At Astatine 85	210 Rn Radon 86				
226 Ra Radium 88	227 Ac Actinium 89											204 Pb Lead 82	207 Pb Lead 82	209 Bi Bismuth 83	210 Po Polonium 84	210 At Astatine 85	210 Rn Radon 86																				
		*58-71 Lanthanoid series †90-103 Actinoid series										140 Ce Cerium 58	141 Pr Praseodymium 59	144 Nd Neodymium 60	150 Sm Samarium 62	152 Eu Europium 63	157 Gd Gadolinium 64	162 Dy Dysprosium 66	165 Ho Holmium 67	167 Er Erbium 68	169 Tm Thulium 69	173 Yb Ytterbium 70	175 Lu Lutetium 71	232 Th Thorium 90	238 U Uranium 92	238 Pa Protactinium 91	238 Np Neptunium 93	238 Pu Plutonium 94	238 Am Americium 95	238 Cm Curium 96	238 Bk Berkelium 97	238 Cf Californium 98	238 Es Einsteinium 99	238 Fm Fermium 100	238 Md Mendelevium 101	238 No Nobelium 102	238 Lr Lawrencium 103

Key

a	X	b
---	----------	---

a = relative atomic mass
X = atomic symbol
b = proton (atomic) number

The volume of one mole of any gas is 24 dm³ at room temperature and pressure (r.t.p.).

Permission to reproduce items where third-party owned material protected by copyright is included has been sought and cleared where possible. Every reasonable effort has been made by the publisher (UCLES) to trace copyright holders, but if any items requiring clearance have unwittingly been included, the publisher will be pleased to make amends at the earliest possible opportunity.

Cambridge International Examinations is part of the Cambridge Assessment Group. Cambridge Assessment is the brand name of University of Cambridge Local Examinations Syndicate (UCLES), which is itself a department of the University of Cambridge.