



UNIVERSITY OF CAMBRIDGE INTERNATIONAL EXAMINATIONS  
International General Certificate of Secondary Education

**COMBINED SCIENCE**

**0653/11**

Paper 1 Multiple Choice

**October/November 2012**

**45 minutes**

Additional Materials: Multiple Choice Answer Sheet  
Soft clean eraser  
Soft pencil (type B or HB is recommended)



**READ THESE INSTRUCTIONS FIRST**

Write in soft pencil.

Do not use staples, paper clips, highlighters, glue or correction fluid.

Write your name, Centre number and candidate number on the Answer Sheet in the spaces provided unless this has been done for you.

There are **forty** questions on this paper. Answer **all** questions. For each question there are four possible answers **A, B, C** and **D**.

Choose the **one** you consider correct and record your choice in **soft pencil** on the separate Answer Sheet.

**Read the instructions on the Answer Sheet very carefully.**

Each correct answer will score one mark. A mark will not be deducted for a wrong answer.

Any rough working should be done in this booklet.

A copy of the Periodic Table is printed on page 20.

This document consists of **17** printed pages and **3** blank pages.



1 Water enters a plant cell.

In what order does the water pass through the cell structures before reaching the vacuole?

- A cell surface membrane → cell wall → cytoplasm
- B cell wall → cell surface membrane → cytoplasm
- C cell wall → cytoplasm → cell surface membrane
- D cytoplasm → cell wall → cell surface membrane

2 What is diffusion?

- A net movement of molecules down a concentration gradient
- B net movement of molecules up a concentration gradient
- C total movement of molecules down a concentration gradient
- D total movement of molecules up a concentration gradient

3 The chemical reactions in photosynthesis depend on enzymes.

Which graph shows the effect of temperature on the rate of these reactions?

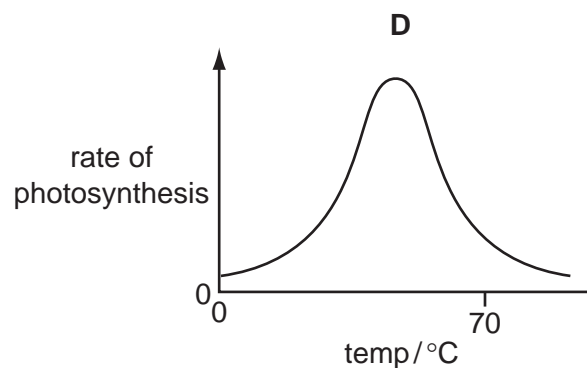
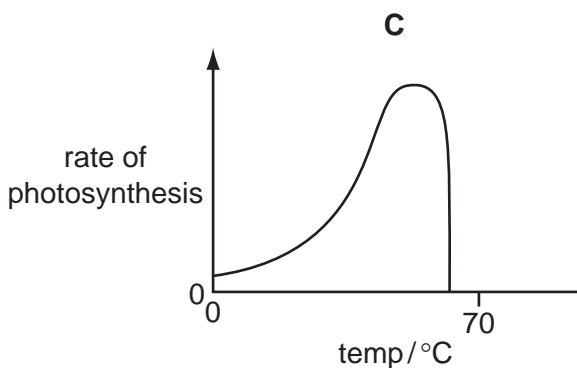
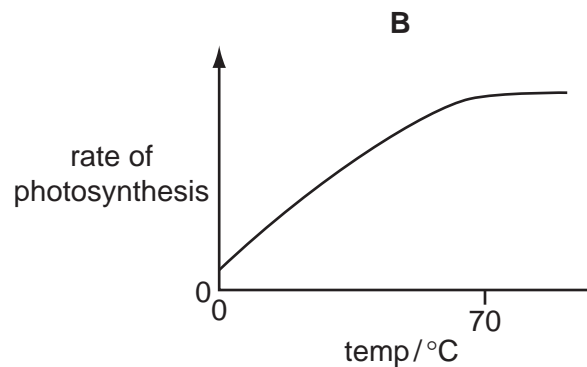
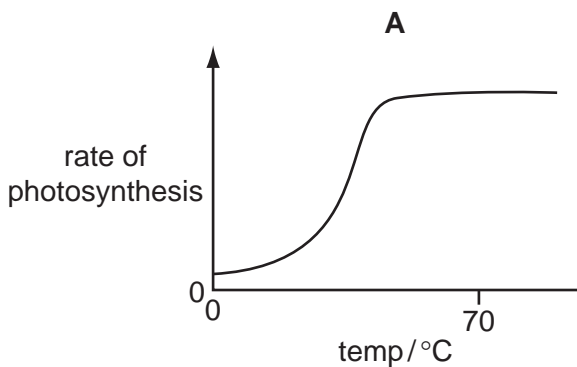

4 Water moves through the stomata of leaves during transpiration.

In which direction, and in which form, does it move?

	direction	form
<b>A</b>	into the leaf	liquid
<b>B</b>	into the leaf	vapour
<b>C</b>	out of the leaf	liquid
<b>D</b>	out of the leaf	vapour

5 Which of these places parts of the alimentary canal in the order in which food passes through them?

- A** oesophagus → colon → small intestine
- B** small intestine → oesophagus → rectum
- C** small intestine → rectum → anus
- D** stomach → colon → small intestine

6 Which part of blood contains haemoglobin?

- A** plasma
- B** platelets
- C** red blood cells
- D** white blood cells

- 7 The diagram shows a plant in a container of water. The layer of oil stops the water evaporating.

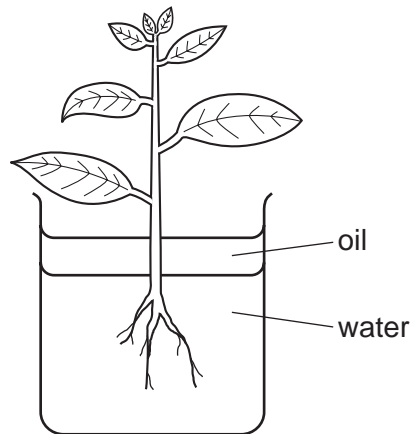

When set up, the apparatus weighs 296 g.  
After two hours it weighs 292 g.

What is the rate of transpiration?

- A 150 g water / hour
- B 148 g water / hour
- C 4 g water / hour
- D 2 g water / hour

- 8 A person does not eat for several hours but then has a meal rich in carbohydrate.

Which graph shows how the person's blood sugar level changes after the meal?

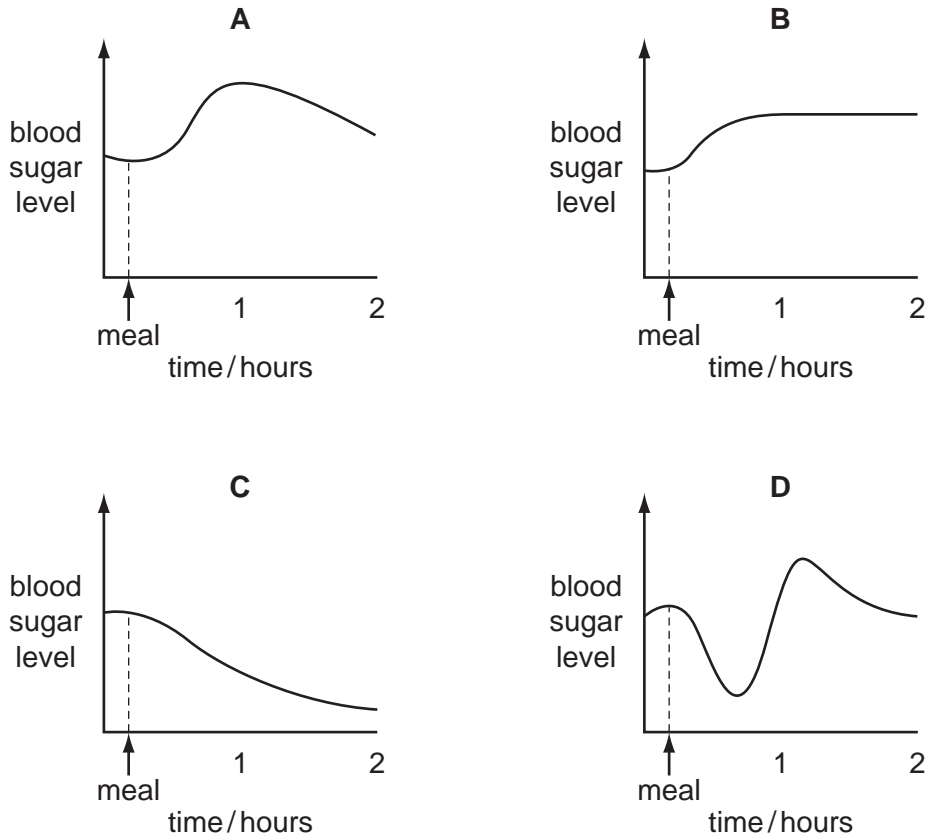

- 9 It is possible to grow plants that are genetically identical.

What are plants grown in this way called?

- A clones
- B gametes
- C seeds
- D zygotes

- 10 The diagram shows the human female reproductive system.

Where is the egg fertilised?

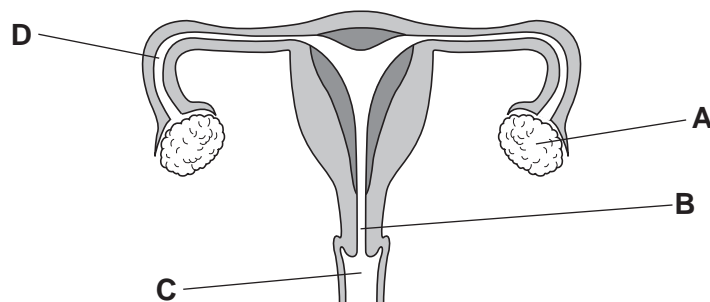

11 Which structures in flowers contain female gametes?

- A anthers
- B ovules
- C stamens
- D stigmas

12 The diagram shows the organisms in a pond.

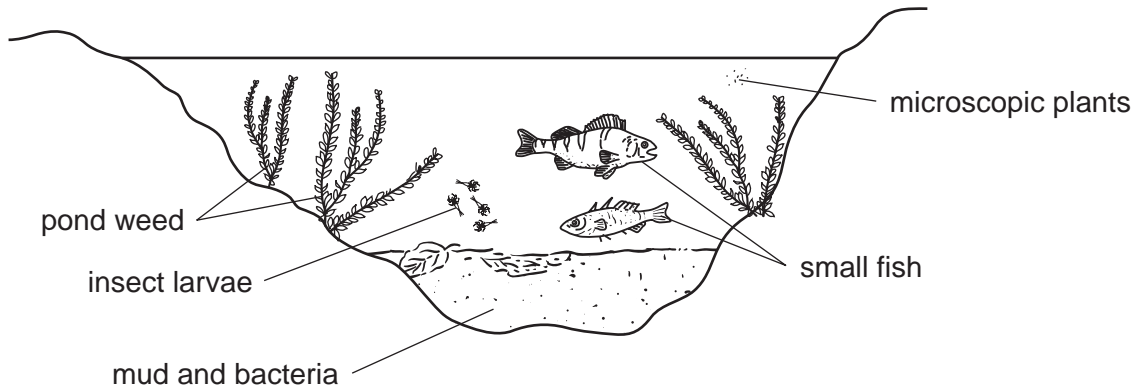

Which is a food chain in this pond?

- A bacteria → pond weed → insect larvae → small fish
- B microscopic plants → insect larvae → small fish → bacteria
- C pond weed → small fish → bacteria → microscopic plants
- D small fish → insect larvae → microscopic plants → pond weed

13 Some of the gases present in the atmosphere are listed.

- 1 carbon dioxide
- 2 methane
- 3 nitrogen
- 4 oxygen

Which gases increase global warming when their levels in the atmosphere increase?

- A 1 and 2
- B 1 and 4
- C 2 and 3
- D 3 and 4

14 The apparatus shown is used to remove sand from a mixture of salt and sand.

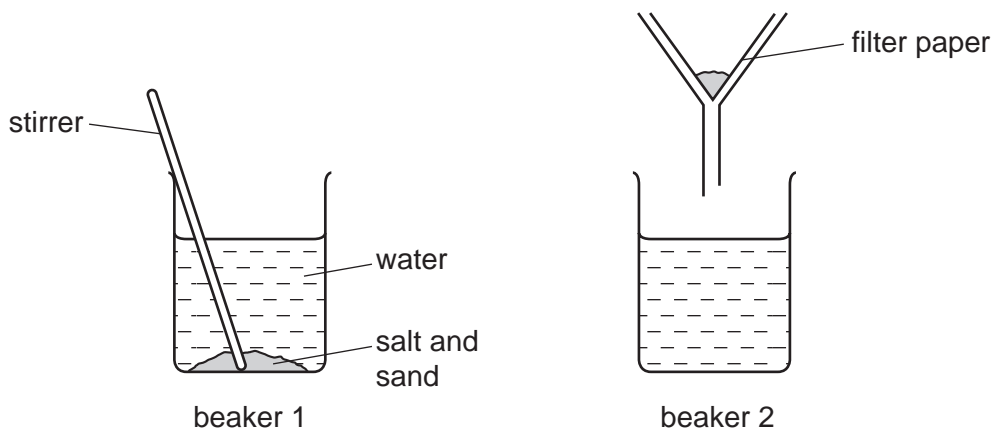

The contents of beaker 1 are filtered.

What is obtained in beaker 2?

- A a mixture of an element and a compound
- B a mixture of two compounds
- C one compound only
- D one element only

15 The electronic configurations of four elements are given.

Which element is found on the left-hand side of the Periodic Table?

- A 2
- B 2, 8, 7
- C 2, 8, 8
- D 2, 8, 8, 2

16 The diagram shows a simple cell.

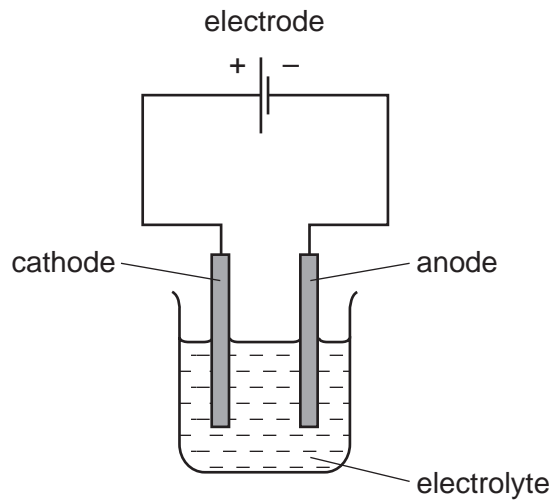

Which label on the diagram is correct?

- A anode
- B cathode
- C electrode
- D electrolyte

17 The diagram shows gas X burning and heating a liquid.

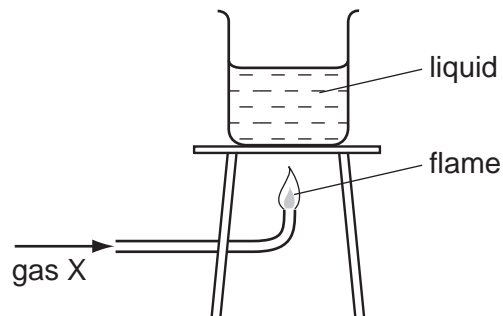

Which row is correct?

	gas X could be	the burning of gas X is exothermic
<b>A</b>	hydrogen	✓
<b>B</b>	hydrogen	x
<b>C</b>	oxygen	✓
<b>D</b>	oxygen	x



- 18 In the beakers, equal masses of magnesium are added to equal volumes of acid of the same concentration.

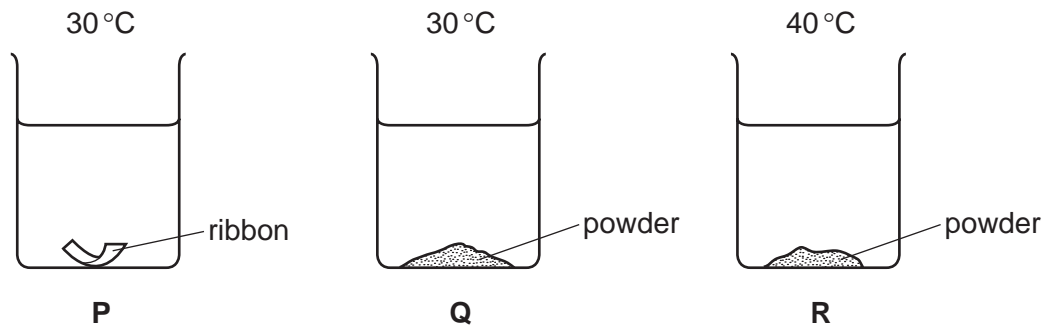

What is the order of the speed of reaction in the beakers?

	slowest	→	fastest
<b>A</b>	P		R
<b>B</b>	P		Q
<b>C</b>	Q		R
<b>D</b>	Q		P

- 19 Dilute sulfuric acid is added to antacid tablets in the apparatus shown.

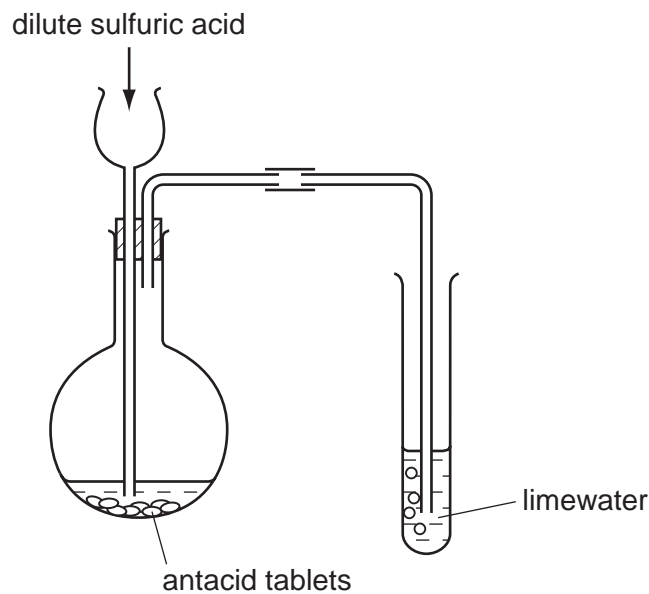

The limewater turns milky.

What does the experiment show these antacid tablets contain?

- A** magnesium
- B** magnesium carbonate
- C** magnesium hydroxide
- D** magnesium oxide

20 Which ion gives a white precipitate **both** with aqueous sodium hydroxide **and** with aqueous ammonia?

- A  $\text{Cu}^{2+}(\text{aq})$       B  $\text{Fe}^{2+}(\text{aq})$       C  $\text{Fe}^{3+}(\text{aq})$       D  $\text{Zn}^{2+}(\text{aq})$

21 The diagram shows an outline of the Periodic Table.

Which two elements have similar chemical properties?

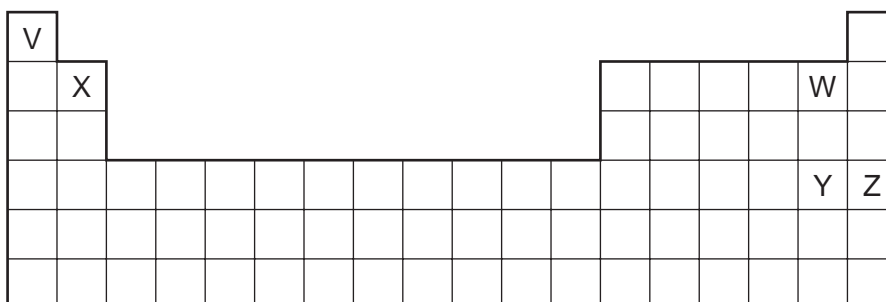

- A V and W      B V and X      C W and Y      D Y and Z

22 The list shows different properties.

- 1 density
- 2 melting point
- 3 reactivity

Which properties show an increase for elements in Group VII as the group is descended?

- A 1 only      B 1 and 2      C 2 and 3      D 3 only

23 Platinite is a material used for parts of light bulbs. It is made by mixing iron and zinc.

Which type of substance is platinite?

- A alloy  
B hydrocarbon  
C ionic compound  
D transition metal

24 Element X is unaffected by acids and is used in an alloy to make jewellery.

X is .....1..... transition metal and the alloy is .....2..... than the pure element.

Which words correctly complete gaps 1 and 2?

	1	2
<b>A</b>	an unreactive	harder
<b>B</b>	an unreactive	softer
<b>C</b>	a reactive	harder
<b>D</b>	a reactive	softer

25 Which pie chart correctly shows the proportions of gases in the air?

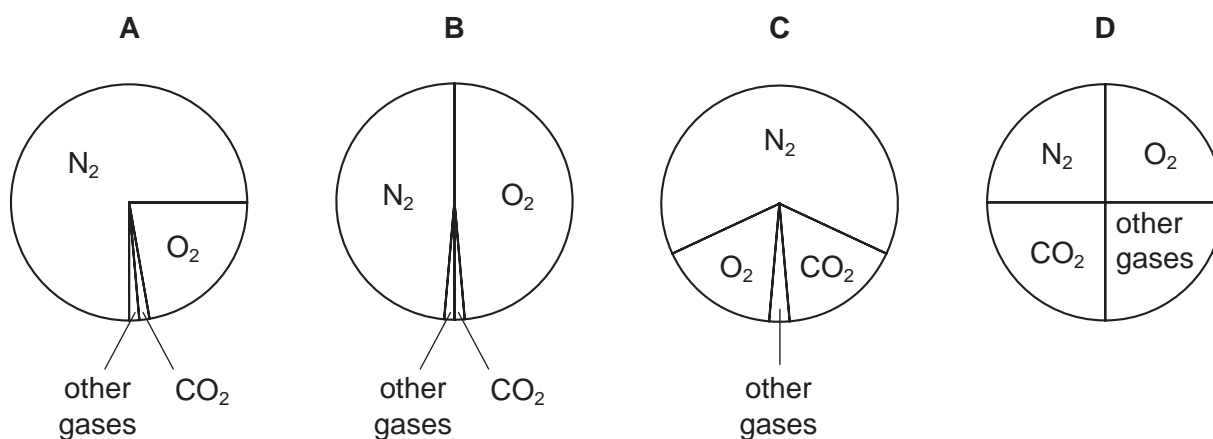

26 A hydrocarbon fuel is burned completely.



What are X and Y?

	X	Y
<b>A</b>	CO	H <sub>2</sub>
<b>B</b>	CO	H <sub>2</sub> O
<b>C</b>	CO <sub>2</sub>	H <sub>2</sub>
<b>D</b>	CO <sub>2</sub>	H <sub>2</sub> O

27 Petroleum is a source of hydrocarbon fuels.

Other fuels are coal and wood.

Which of these are fossil fuels?

	coal	wood	petroleum
<b>A</b>	yes	yes	no
<b>B</b>	yes	no	yes
<b>C</b>	no	yes	yes
<b>D</b>	yes	yes	yes

28 The diagram is a speed/time graph for a car travelling along a city street.

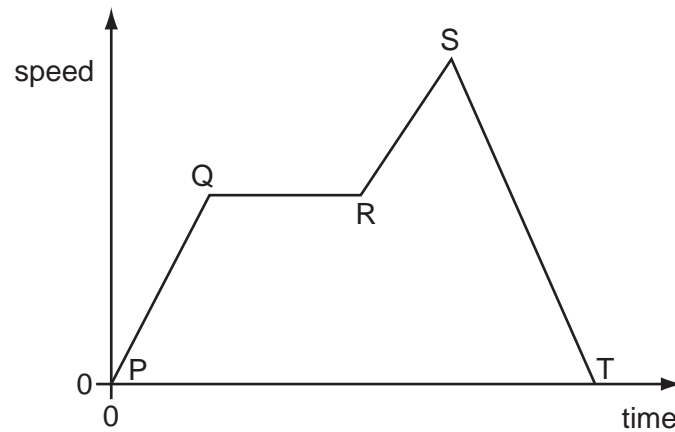

Where on the graph is the car moving with changing speed?

- A** PQ, QR, RS and ST
- B** PQ, RS and ST only
- C** PQ and RS only
- D** QR only

29 The diagram shows two cubes P and Q. The lengths of their sides and their masses are given.

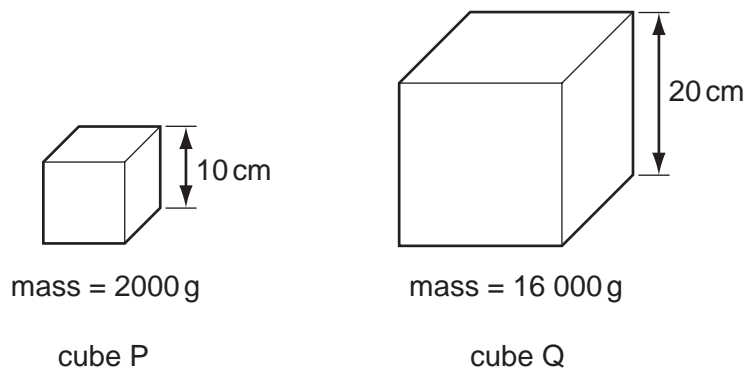

What is the density of the material of cube Q?

- A half that of cube P
  - B the same as that of cube P
  - C twice that of cube P
  - D four times that of cube P
- 30 What is the unit of work?
- A joule
  - B kilogram
  - C newton
  - D watt
- 31 The melting point of water is  $0^{\circ}\text{C}$  and the boiling point of water is  $100^{\circ}\text{C}$ .
- Which statement about water is correct?
- A At  $100^{\circ}\text{C}$  boiling occurs throughout the water.
  - B Between  $0^{\circ}\text{C}$  and  $100^{\circ}\text{C}$  the lowest energy molecules escape.
  - C Between  $0^{\circ}\text{C}$  and  $100^{\circ}\text{C}$  water does not evaporate.
  - D Ice only melts when its temperature is above  $0^{\circ}\text{C}$ .
- 32 In which state(s) of matter can convection occur?
- A solids and liquids
  - B solids and gases
  - C liquids and gases
  - D liquids only

33 A wave is sent along a rope in the direction shown in the diagram.

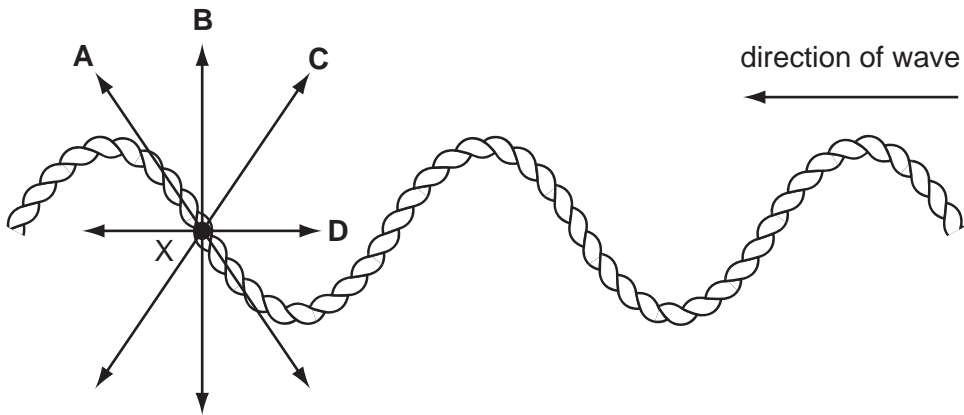

Which arrow shows the direction of vibration of the rope at point X?

34 The diagram shows the position of the eye of a person looking at the reflection of a toy rabbit in a plane mirror.

At which position is the image seen?

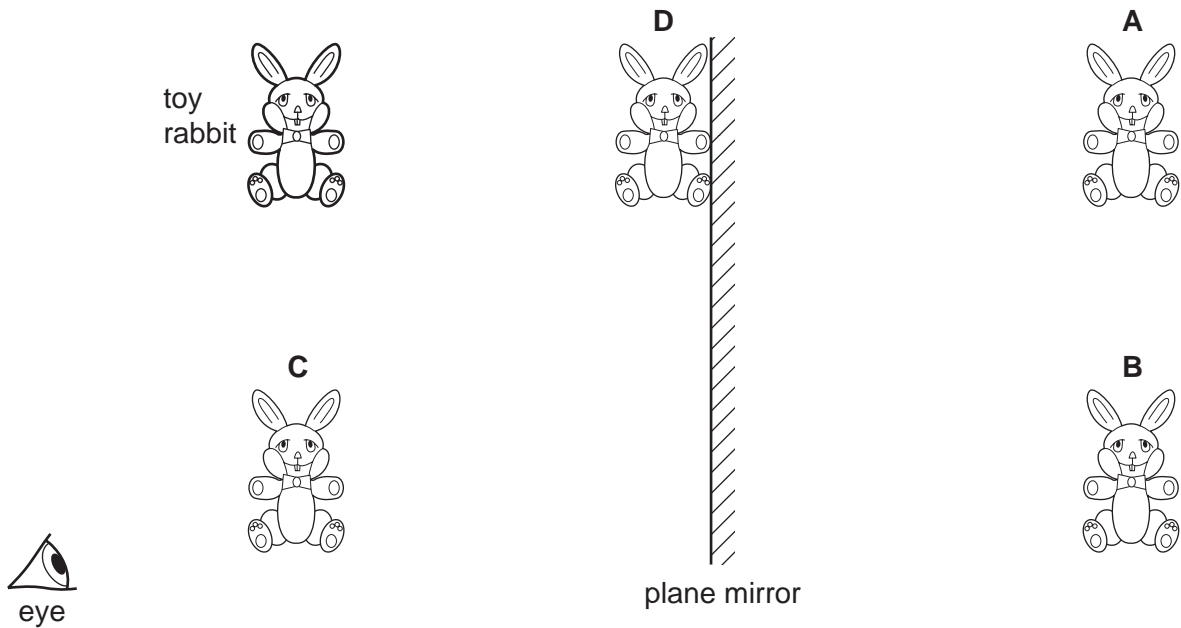

- 35 A ray of light strikes one face of a parallel-sided glass block. The angle of incidence is  $46^\circ$ .  
At the opposite face, part of the ray is reflected and part is refracted into the air.

Which other angle has a value of  $46^\circ$ ?

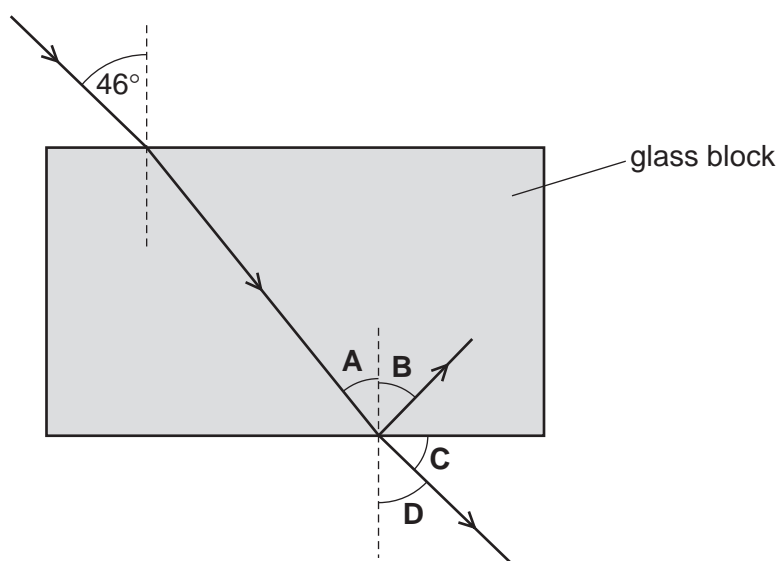

- 36 The diagram shows a filament lamp.

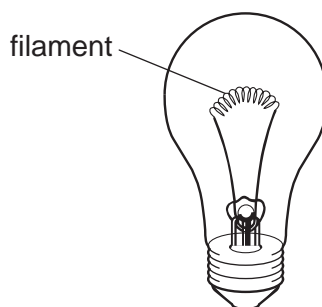

What are the main types of wave given out by the filament once the lamp is lit?

- A visible light and infra-red
  - B visible light and microwaves
  - C visible light and radio
  - D visible light and ultraviolet
- 37 A starting pistol is fired. An echo from a wall 150 m away is heard one second later.  
What is the speed of sound calculated from these results?
- A 75 m/s      B 150 m/s      C 225 m/s      D 300 m/s

38 A student sets up a circuit to find the resistance of a length of wire.

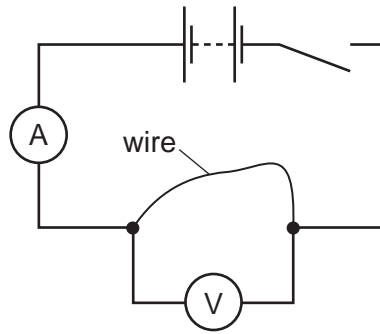

When the switch is closed, the ammeter reads 2 A and the voltmeter reads 10 V.

What is the resistance of the length of wire?

- A**  $0.2\ \Omega$       **B**  $5\ \Omega$       **C**  $8\ \Omega$       **D**  $20\ \Omega$

39 In an electrical circuit, what is the purpose of a fuse?

- A** to connect the metal case of an appliance to the earth  
**B** to cut off the electrical supply if too much current flows  
**C** to keep an electrical appliance dry in damp conditions  
**D** to maintain a steady voltage as the current varies

40 When the switch in the circuit shown is closed, the lamp glows dimly.

Which component can be adjusted to make the lamp brighter?

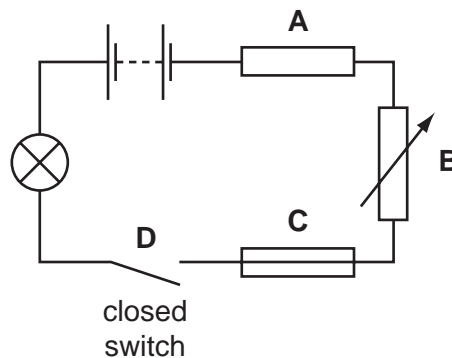









**DATA SHEET**  
**The Periodic Table of the Elements**

		Group										
		I	II	III	IV	V	VI	VII	VIII	IX	X	
		1 <b>H</b> Hydrogen 1										
7	9											
<b>Li</b> Lithium 3	<b>Be</b> Beryllium 4											
23	24											
<b>Na</b> Sodium 11	<b>Mg</b> Magnesium 12											
39	40											
<b>K</b> Potassium 19	<b>Ca</b> Calcium 20	45	48	51	52	55	56	59	59	64	65	
		<b>Sc</b> Scandium 21	<b>Ti</b> Titanium 22	<b>V</b> Vanadium 23	<b>Cr</b> Chromium 24	<b>Mn</b> Manganese 25	<b>Fe</b> Iron 26	<b>Co</b> Cobalt 27	<b>Ni</b> Nickel 28	<b>Cu</b> Copper 29	<b>Zn</b> Zinc 30	
85	88	89	91	93	96	101	101	103	106	108	112	
<b>Rb</b> Rubidium 37	<b>Sr</b> Strontium 38	<b>Y</b> Yttrium 39	<b>Zr</b> Zirconium 40	<b>Nb</b> Niobium 41	<b>Mo</b> Molybdenum 42	<b>Ru</b> Ruthenium 44	<b>Rh</b> Rhodium 45	<b>Pd</b> Palladium 46	<b>Ag</b> Silver 47	<b>Cd</b> Cadmium 48		
133	137	139	178	181	184	190	190	192	195	197	201	
<b>Cs</b> Caesium 55	<b>Ba</b> Barium 56	<b>La</b> Lanthanum 57	<b>Hf</b> Hafnium 72	<b>Ta</b> Tantalum 73	<b>W</b> Tungsten 74	<b>Os</b> Osmium 76	<b>Ir</b> Iridium 77	<b>Pt</b> Platinum 78	<b>Au</b> Gold 79	<b>Hg</b> Mercury 80		
226	227											
<b>Fr</b> Francium 87	<b>Ra</b> Radium 88	<b>Ac</b> Actinium 89										
*58-71 Lanthanoid series †90-103 Actinoid series												
		140	141	144	150	152	157	159	162	165	167	
		<b>Ce</b> Cerium 58	<b>Pr</b> Praseodymium 59	<b>Nd</b> Neodymium 60	<b>Pm</b> Promethium 61	<b>Sm</b> Samarium 62	<b>Eu</b> Europium 63	<b>Gd</b> Gadolinium 64	<b>Dy</b> Dysprosium 66	<b>Ho</b> Holmium 67	<b>Er</b> Erbium 68	
		232	238	238	238	238	238	238	238	238	238	
		<b>Th</b> Thorium 90	<b>Pa</b> Protactinium 91	<b>U</b> Uranium 92	<b>Np</b> Neptunium 93	<b>Pu</b> Plutonium 94	<b>Am</b> Americium 95	<b>Cm</b> Curium 96	<b>Cf</b> Californium 98	<b>Es</b> Einsteinium 99	<b>Fm</b> Fermium 100	
		169	173	173	173	173	173	173	173	173	173	
		<b>Tm</b> Thulium 69	<b>Yb</b> Ytterbium 70	<b>Lu</b> Lutetium 71	<b>Y</b> Yttrium 39	<b>Rn</b> Radon 86	<b>At</b> Astatine 85	<b>Po</b> Polonium 84	<b>Bi</b> Bismuth 83	<b>Pb</b> Lead 82	<b>Tl</b> Thallium 81	
		103	102	102	102	102	102	102	102	102	102	
		<b>Lr</b> Lawrencium 103	<b>No</b> Nobelium 102	<b>Md</b> Mendelevium 101	<b>Fm</b> Fermium 100	<b>At</b> Astatine 85	<b>Po</b> Polonium 84	<b>Bi</b> Bismuth 83	<b>Pb</b> Lead 82	<b>Tl</b> Thallium 81		

Key

a	<b>X</b>
b	

a = relative atomic mass  
X = atomic symbol  
b = proton (atomic) number

The volume of one mole of any gas is 24 dm<sup>3</sup> at room temperature and pressure (r.t.p.).

Permission to reproduce items where third-party owned material protected by copyright is included has been sought and cleared where possible. Every reasonable effort has been made by the publisher (UCLES) to trace copyright holders, but if any items requiring clearance have unwittingly been included, the publisher will be pleased to make amends at the earliest possible opportunity.

University of Cambridge International Examinations is part of the Cambridge Assessment Group. Cambridge Assessment is the brand name of University of Cambridge Local Examinations Syndicate (UCLES), which is itself a department of the University of Cambridge.