



UNIVERSITY OF CAMBRIDGE INTERNATIONAL EXAMINATIONS
International General Certificate of Secondary Education

CANDIDATE
NAME

CENTRE
NUMBER

--	--	--	--	--

CANDIDATE
NUMBER

--	--	--	--	--

* 5 9 0 8 0 7 6 9 0 2 *

COMBINED SCIENCE

0653/31

Paper 3 (Extended)

October/November 2011

1 hour 15 minutes

Candidates answer on the Question Paper.

No Additional Materials are required.

READ THESE INSTRUCTIONS FIRST

Write your Centre number, candidate number and name on all the work you hand in.

Write in dark blue or black pen.

You may use a soft pencil for any diagrams, graphs, tables or rough working.

Do not use staples, paper clips, highlighters, glue or correction fluid.

DO NOT WRITE IN ANY BARCODES.

Answer **all** questions.

A copy of the Periodic Table is printed on page 20.

At the end of the examination, fasten all your work securely together.

The number of marks is given in brackets [] at the end of each question or part question.

For Examiner's Use	
1	
2	
3	
4	
5	
6	
7	
8	
9	
Total	

This document consists of **19** printed pages and **1** blank page.



- 1 The chemical reaction involved in the manufacture of ammonia requires an iron catalyst.

Fig.1.1 shows a simplified diagram of the reaction vessel in which ammonia is made.

For
Examiner's
Use

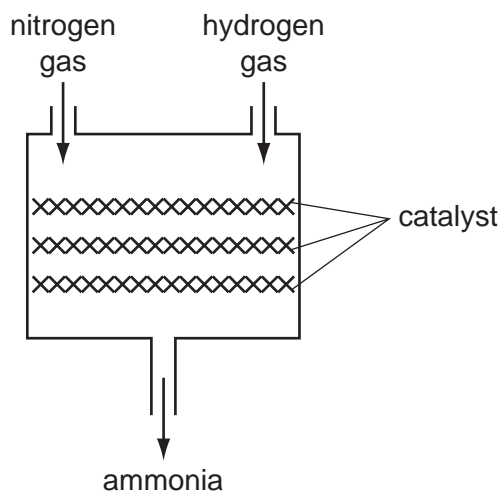

Fig. 1.1

- (a) (i) Explain the meaning of the term *catalyst*.

.....
..... [2]

- (ii) Iron is a member of the family of metals which lies between scandium and zinc in the Periodic Table.

Name this family of metals. [1]

- (iii) The iron catalyst is prepared by reacting iron oxide with hydrogen gas.

The symbolic equation below for this reaction is **not** balanced.

Complete the balancing of the equation.



- (iv) Explain, in terms of the loss or gain of electrons, whether iron is oxidised or reduced in the reaction in (iii).

.....
.....
..... [2]

(v) Calculate the relative formula mass of iron oxide, Fe_3O_4 .

Show your working.

For
Examiner's
Use

..... [2]

(b) Complete the bonding diagram below to show

- the chemical symbols of the elements in a molecule of ammonia,
- the arrangement of the outer electrons of each atom.

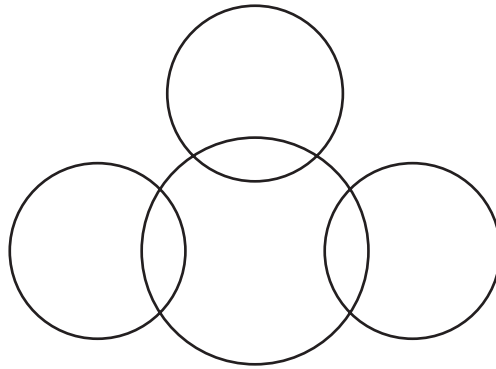

[3]

- 2 The golden lion tamarin is a species of monkey that lives in forests in Brazil. Its diet includes fruits and nectar from trees. Its predators include snakes, bamboo rats and owls.

For
Examiner's
Use



- (a) (i) In the space below, construct a food web involving golden lion tamarins.

[3]

- (ii) Using your knowledge of energy flow through food chains, explain why predators such as owls are usually rarer than the prey on which they feed.

.....

.....

.....

..... [2]

- (b) Golden lion tamarins are important for the dispersal of seeds from many different species of trees. They eat the fruits and then egest the seeds in their faeces.

For
Examiner's
Use

An investigation was carried out into the distances that golden lion tamarins dispersed seeds from trees.

Fig. 2.1 shows the results of a study in which the distances of the tamarin's faeces from one tree were measured.

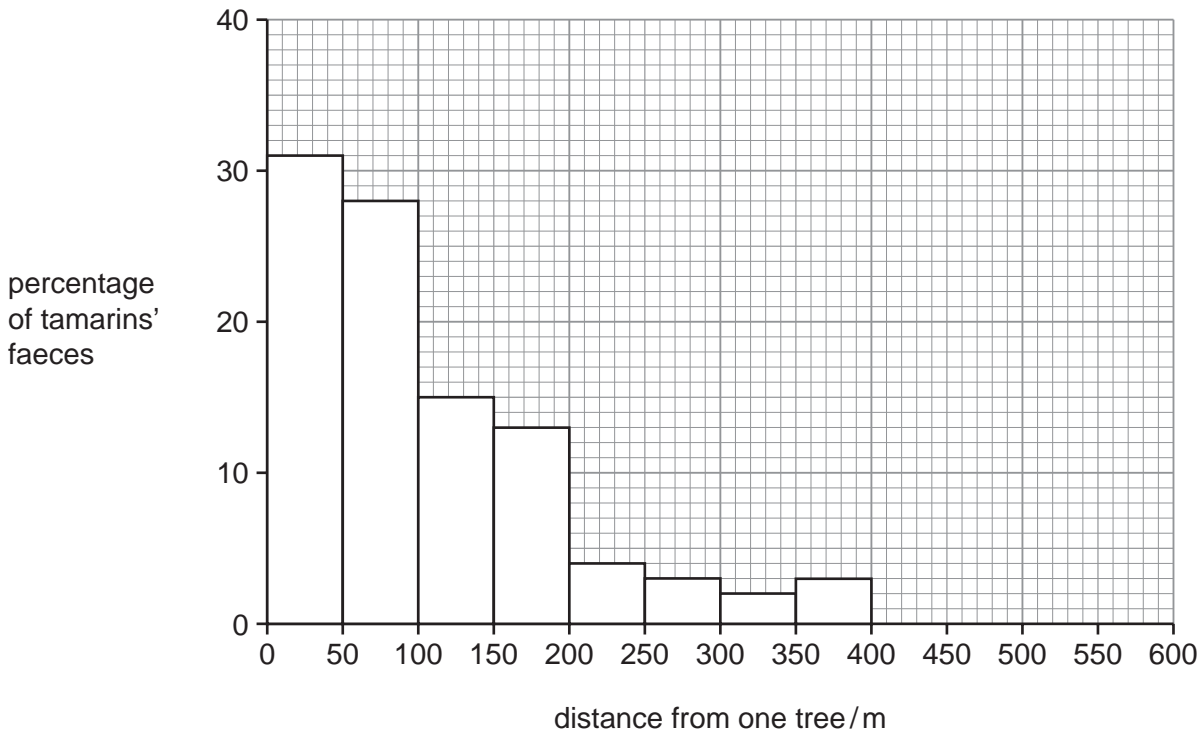

Fig. 2.1

- (i) Describe the distribution of golden lion tamarin faeces in relation to this tree.

.....

 [2]

- (ii) Suggest how the dispersal of seeds away from the tree, in golden lion tamarin faeces, could benefit the young plants that grow from the seeds.

.....

 [3]

3 Fig. 3.1 shows two cars.

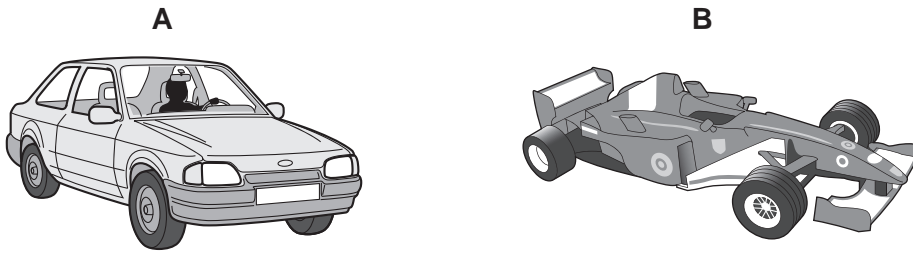

Fig. 3.1

(a) Explain which of these cars, **A** or **B**, is less likely to overturn if it goes round a corner at high speed.

.....
.....
..... [2]

(b) Car **B** took 1.5 hours to complete a race of 330 kilometres.

Calculate the average speed of the car in kilometres per hour.

State the formula that you use and show your working.

formula used

working

..... [2]

(c) Fig. 3.2 shows the speed-time graph for the racing car over a short period.

For
Examiner's
Use

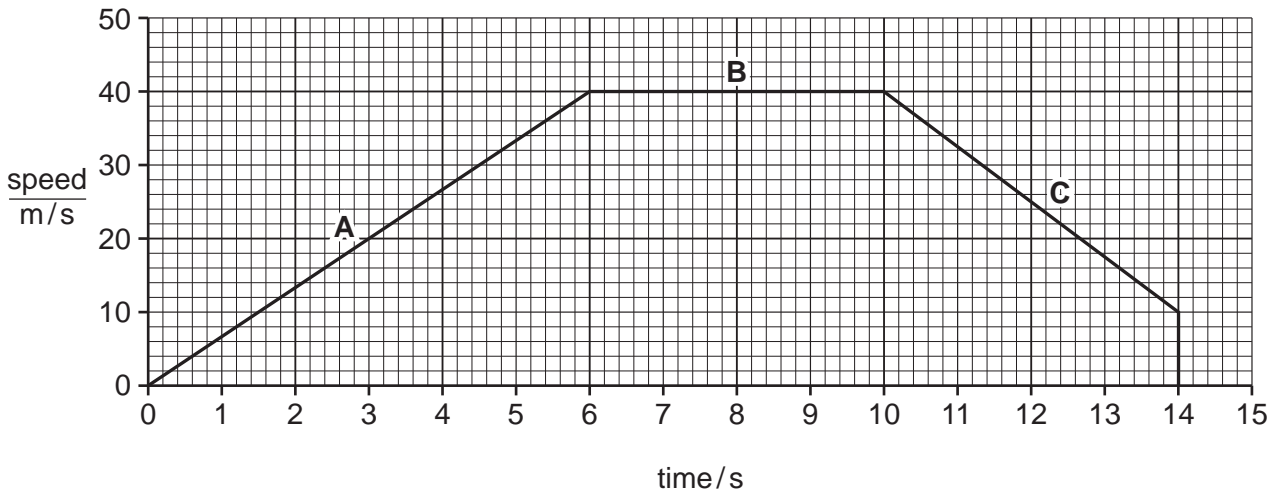

Fig. 3.2

(i) Describe the motion of the racing car during

section **B**,

section **C**. [2]

(ii) Calculate the distance travelled over the first 10 seconds.

Show your working.

..... [2]

(iii) The car is accelerating during section **A**.

Calculate the acceleration.

Show your working.

..... [2]

(iv) The car and driver have a total mass of 1500 kg.

Calculate the force that produced the acceleration during section **A**.

State the formula that you use and show your working.

formula used

working

..... [2]

*For
Examiner's
Use*

4 (a) Fig. 4.1 shows some of the structures involved in a reflex action.

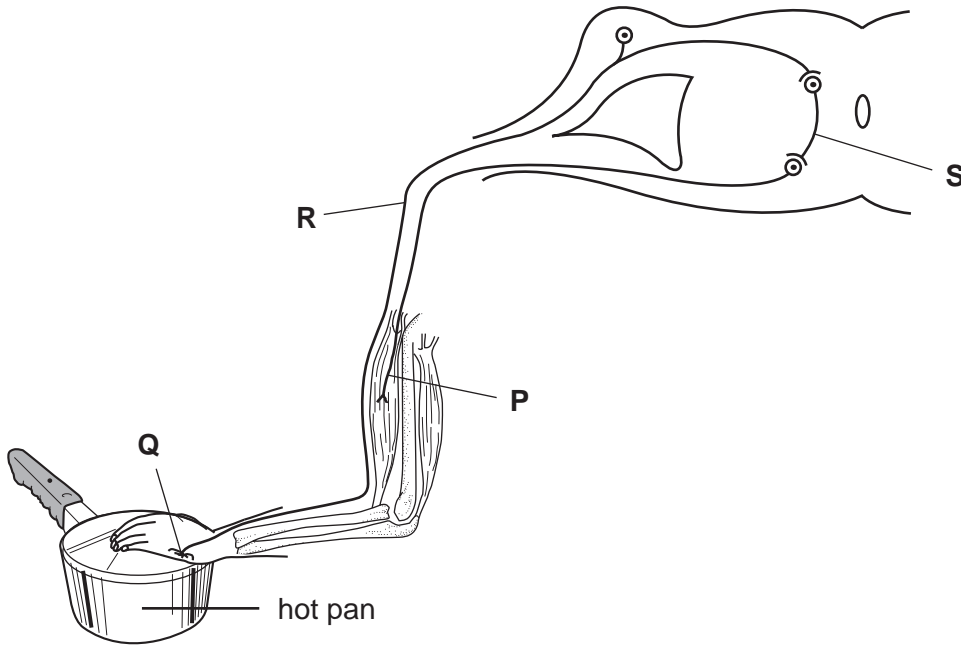

Fig. 4.1

(i) State the **letter** that is labelling each of these structures.

a receptor

a sensory neurone [2]

(ii) On Fig. 4.1, draw **one** arrow on structure **R** and **one** arrow on structure **S** to show the direction in which a nerve impulse travels. [1]

(iii) On Fig. 4.1, label **one** structure that is part of the central nervous system. [1]

(iv) In this reflex action, touching the hot pan causes arm muscles to contract and move the arm away.

Describe **one** advantage of this being a reflex action, rather than a voluntary action.

..... [1]

(b) Each neurone has a nucleus, which contains chromosomes made of DNA.

(i) Name **one** type of cell in the human body that does **not** contain a nucleus. [1]

.....

(ii) In humans, a sperm cell has 23 chromosomes.

Suggest the number of chromosomes that is present in a neurone. [1]

.....

- 5 (a) Fig. 5.1 shows a piece of magnesium ribbon which a student has just dropped into a container of dilute sulfuric acid.

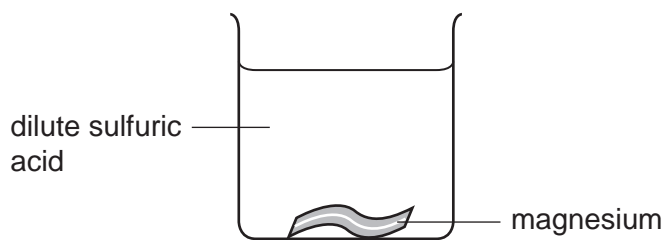

Fig. 5.1

- (i) State how an increase in temperature will change the rate at which the magnesium and acid react.

..... [1]

- (ii) Explain your answer to (i) in terms of particles.

.....

 [2]

- (b) Sulfuric acid containers are often made of poly(ethene). Poly(ethene) is a polymer which is formed from hydrocarbon monomers.

- (i) Suggest **one** property of poly(ethene) which makes it suitable for making sulfuric acid containers.

..... [1]

- (ii) Ethene is an unsaturated hydrocarbon which is manufactured from saturated hydrocarbons by cracking.

Outline the process of cracking.

.....

 [2]

For
Examiner's
Use

- 6 (a) Fig. 6.1 shows the circuit diagram of a circuit constructed by a student. Ammeters A_1 , A_2 , A_3 , A_4 and A_5 are used to measure current.

For
Examiner's
Use

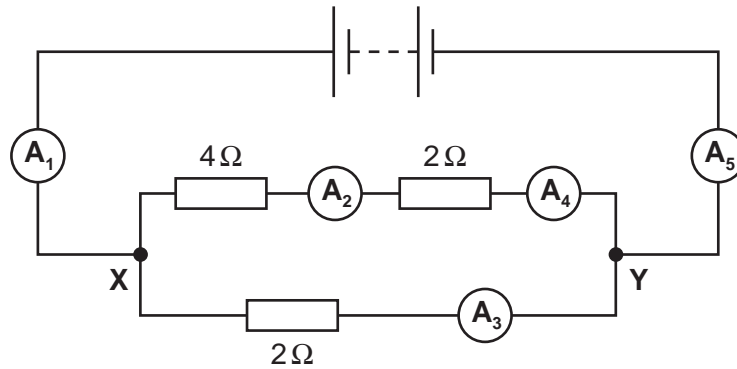

Fig. 6.1

- (i) The readings on A_2 , A_3 and A_5 are shown in Table 6.1.

Table 6.1

Ammeter	Reading
A_2	2 A
A_3	6 A
A_5	8 A

State the readings on A_1 and A_4 .

A_1 A_4 [2]

- (ii) The power input to one of the 2Ω resistors is 72 W.

Calculate how many joules of energy are transferred in 20 seconds.

State the formula that you use and show your working.

formula used

working

..... [2]

(iii) Calculate the total resistance between X and Y.

State the formula that you use and show your working.

formula used

working

..... [3]

(b) Transformers increase the voltage of the electricity generated at a power station before transmission through power lines.

(i) State why this is done.

.....
..... [1]

(ii) A transformer changes the voltage from 25 000 V to 600 000 V.

Use the equation

$$V_p/V_s = N_p/N_s$$

to calculate the ratio of the number of turns on the primary coil to the number on the secondary coil.

..... [2]

For
Examiner's
Use

- 7 (a) Table 7.1 shows some information about enzymes found in the human alimentary canal.

For
Examiner's
Use

Complete the table.

Table 7.1

enzyme	one site of action	type of nutrient that is broken down	product that is formed
	mouth		
		protein	

[3]

- (b) In some parts of the world, people are unable to get enough food or to eat a balanced diet. Young children in some regions of Asia may have a diet that consists mostly of rice, while in some parts of Africa a young child's diet may consist mostly of cassava.

Table 7.2 shows the main nutrients present in 100g of white rice and 100g of cassava.

Table 7.2

nutrient	white rice	cassava
protein/g	5.0	1.2
carbohydrate/g	58.6	34.7
fat/g	0.4	0.3

- (i) A diet that consists mostly of rice is better for a young child than a diet that consists mostly of cassava.

Use the information in Table 7.2 to explain **one** reason why this is so.

.....

.....

..... [2]

- (ii) Carbohydrates include sugars and starch. Describe how a student could test a sample of cooked rice to find out if it contains reducing sugar.

.....

.....

.....

..... [3]

- (iii) The parts of a cassava plant that are used as food are the roots, which store carbohydrate in the form of starch. The cells in the cassava roots are provided with carbohydrates that have been made by photosynthesis in the leaves.

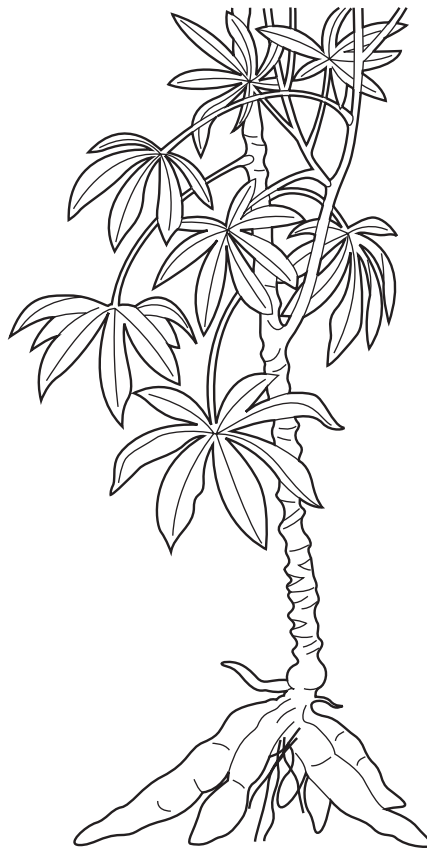

Describe how carbohydrates that have been made in the cassava plant's leaves are transported to the roots.

.....

.....

..... [2]

8 Fig. 8.1 shows some data about the percentage composition by mass of the Earth's crust.

For
Examiner's
Use

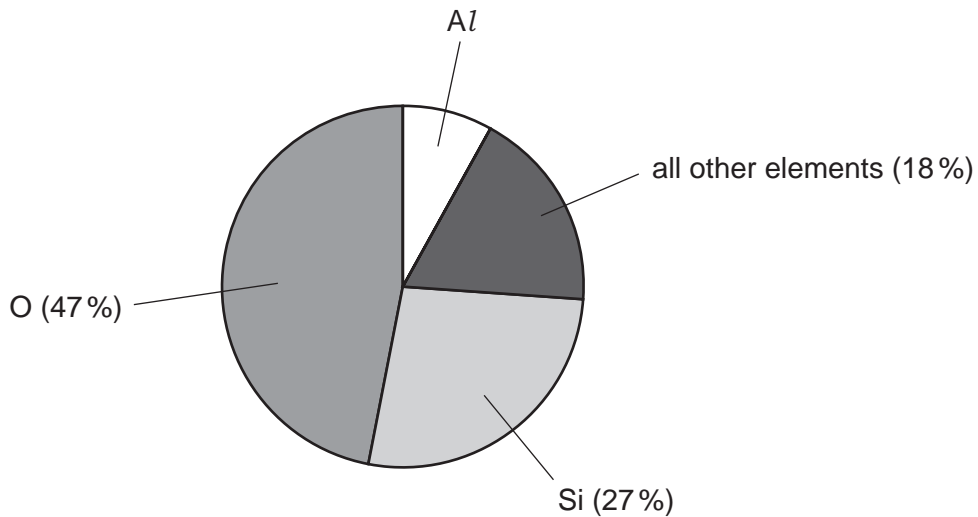

Fig. 8.1

(a) (i) State the percentage by mass of aluminium in the Earth's crust.

..... [1]

(ii) State which of the following numbers is most likely to represent the number of elements in the section labelled *all other elements* in Fig. 8.1.

- 39 89 139 1089

Explain briefly how you chose your answer.

number

explanation

..... [1]

(b) Aluminium metal may be obtained by the electrolysis of molten aluminium oxide.

For
Examiner's
Use

Fig. 8.2 shows a simplified diagram of this process.

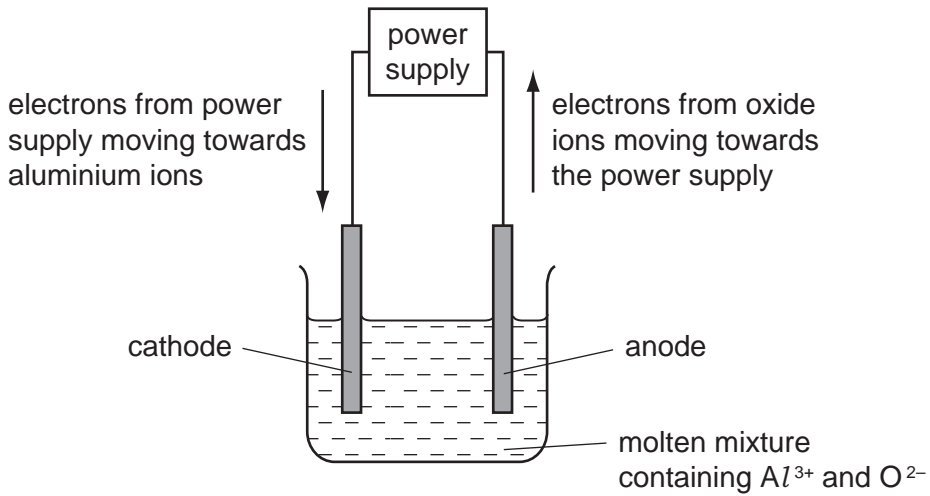

Fig. 8.2

Electrons move through the connecting wires in the directions shown in Fig. 8.2, and ions are converted into uncharged atoms at the surfaces of the electrodes.

(i) Explain briefly why the mixture containing aluminium oxide must be kept molten.

.....
 [1]

(ii) Explain briefly why oxygen atoms are formed at the anode and **not** the cathode.

.....

 [2]

(iii) Explain why, when **six** electrons move around the circuit, **two** aluminium atoms and **three** oxygen atoms are formed.

.....

 [3]

9 (a) Some types of food are treated with gamma radiation. Low doses of radiation slow down the ripening processes in fresh fruit, whilst higher doses of radiation kill the microbes that make food decay.

(i) Explain why gamma radiation can be used for this, even when the fruit is packed in boxes.

.....
 [1]

(ii) Complete the sentences below by crossing out the incorrect words in each box.

Isotopes of the same element have atoms with

the same number
different numbers

 of protons

and

the same number
different numbers

 of neutrons. [1]

(iii) Fig. 9.1 shows how a conveyor belt can be used to move the fresh fruit past the radioactive source.

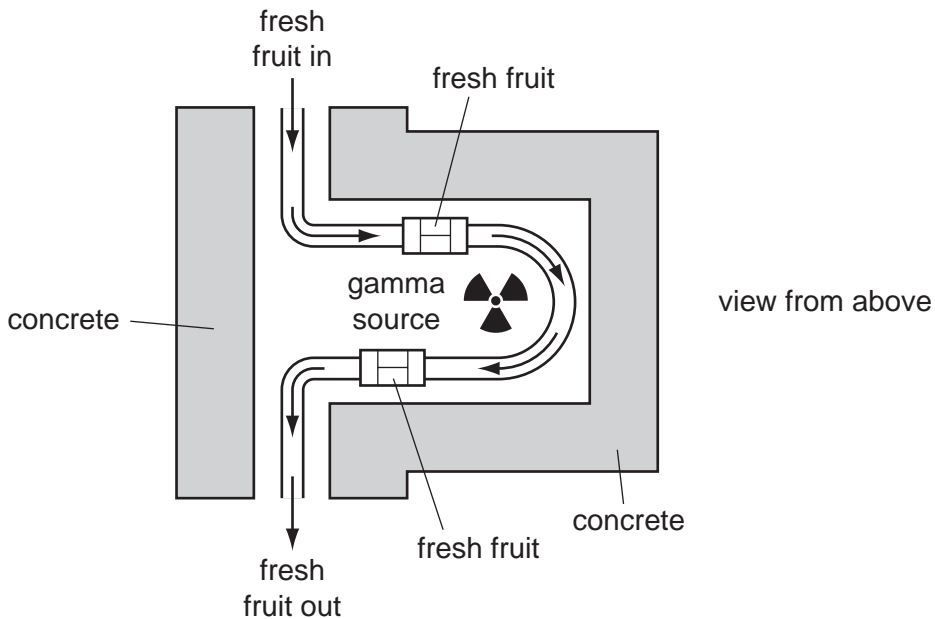

Fig. 9.1

Suggest why concrete is used to surround the radioactive source.

.....
 [1]

(b) Some people may not like the idea of eating fruit which has been treated with radiation. They wrongly think that the food will be radioactive.

For
Examiner's
Use

(i) Describe **one** way in which a scientist could show that the food is **not** radioactive.

.....
..... [1]

(ii) Explain why the food will **not** be radioactive.

.....
..... [1]

