

Centre Number	Candidate Number	Name
---------------	------------------	------

CAMBRIDGE INTERNATIONAL EXAMINATIONS
International General Certificate of Secondary Education

COMBINED SCIENCE

0653/01

Paper 1 Multiple Choice

October/November 2003

45 minutes

Additional Materials: Multiple Choice Answer Sheet
Soft clean eraser
Soft pencil (type B or HB is recommended)

READ THESE INSTRUCTIONS FIRST

Write in soft pencil.

Do not use staples, paper clips, highlighters, glue or correction fluid.

Write your name, Centre number and candidate number on the answer sheet in the spaces provided unless this has been done for you.

There are **forty** questions on this paper. Answer **all** questions. For each question there are four possible answers **A, B, C, and D**.

Choose the **one** you consider correct and record your choice in **soft pencil** on the separate answer sheet.

Read the instructions on the Answer Sheet very carefully.

Each correct answer will score one mark. A mark will not be deducted for a wrong answer.

Any rough working should be done in this booklet.

A copy of the Periodic Table is printed on page 20.

This document consists of **18** printed pages and **2** blank pages.

- 1 The diagram shows a section through a leaf on a hot and still day. The arrow shows the movement of water vapour.

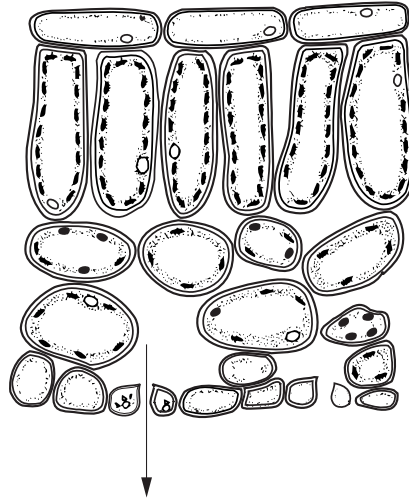

By which process is the water vapour moving out of the leaf?

- A absorption
 B diffusion
 C photosynthesis
 D secretion
- 2 Three test tubes, X, Y and Z each contain the same volume of dilute hydrogen peroxide solution. Equal volumes of raw potato are added to each tube but the potato is cut into different sized pieces.

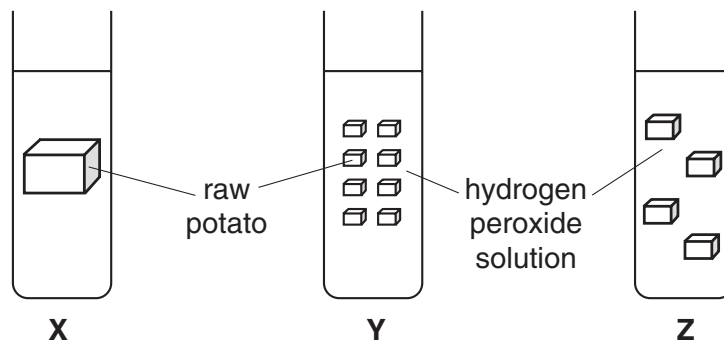

The rate of reaction is different in each tube.

What is the correct order?

	highest rate → lowest rate		
A	X	Y	Z
B	Y	Z	X
C	Z	X	Y
D	Z	Y	X

3 Which energy conversion occurs during photosynthesis?

- A chemical \rightarrow light
- B light \rightarrow chemical
- C heat \rightarrow light
- D light \rightarrow heat

4 A water plant is exposed to sunlight. After a short period of time bubbles are given off from the plant.

Which gas do the bubbles contain, and which process produces this gas?

	gas	process
A	carbon dioxide	photosynthesis
B	carbon dioxide	respiration
C	oxygen	photosynthesis
D	oxygen	respiration

5 Tests carried out on a sick student show that he is deficient in calcium.

What are his symptoms?

- A anaemia
- B bleeding gums
- C breathlessness
- D poor bone growth

6 Tests were performed on four samples of food. The results are shown in the table.

Which food contains protein **only**?

food sample	results of food tests		
	Benedict's test	biuret test	iodine test
A	blue	blue	blue/black
B	blue	purple	brown
C	red	blue	blue/black
D	red	purple	brown

7 The diagrams show alveoli from the lungs.

Which one will allow oxygen to diffuse into the blood most rapidly?

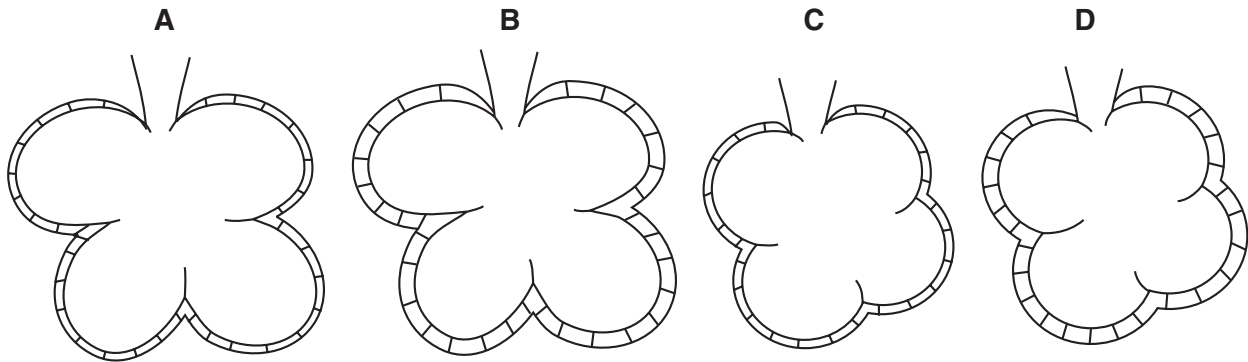

8 The diagram shows the blood supply to a group of muscle cells in the heart.

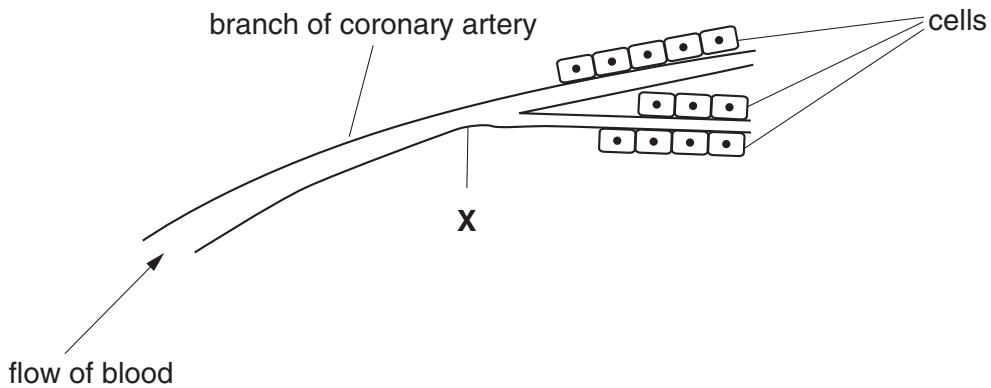

A blockage at point X causes a heart attack because a vital substance cannot reach the cells of the heart.

What is the vital substance?

- A amino acid
- B carbon dioxide
- C oxygen
- D urea

9 The drawing shows some blood, as it appears under the microscope.

Which part carries glucose to muscles?

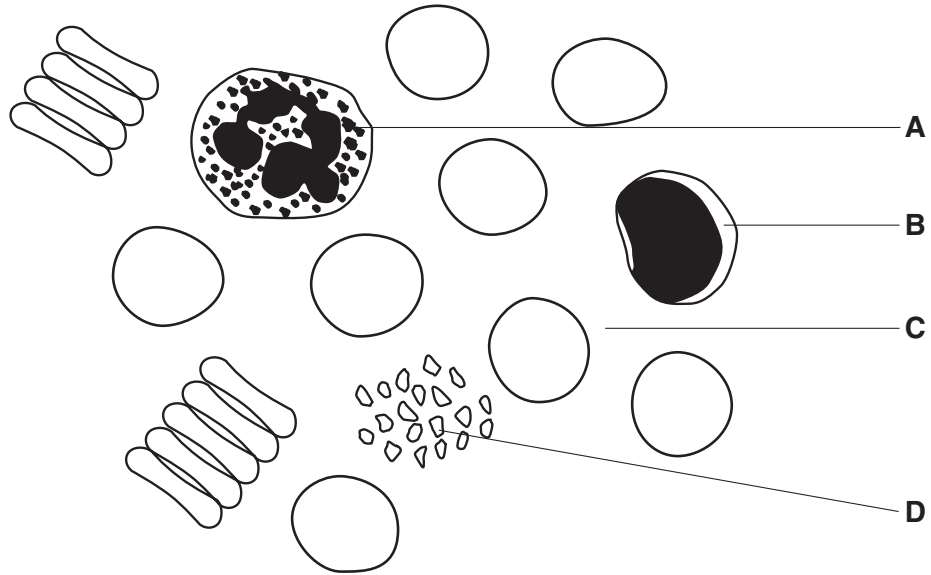

10 Water moves through the stomata of leaves during transpiration.

In which direction, and in which form, does it move?

	direction	form
A	into the leaf	liquid
B	into the leaf	vapour
C	out of the leaf	liquid
D	out of the leaf	vapour

11 In what order are these structures involved in responding to a stimulus?

- A** central nervous system → effector → receptor
- B** effector → central nervous system → receptor
- C** receptor → central nervous system → effector
- D** receptor → effector → central nervous system

12 During pollination, pollen grains are transferred from

- A anther to ovule.
- B anther to stigma.
- C stigma to anther.
- D stigma to ovule.

13 The diagram shows the human female reproductive organs.

Where is a fertilised egg normally implanted?

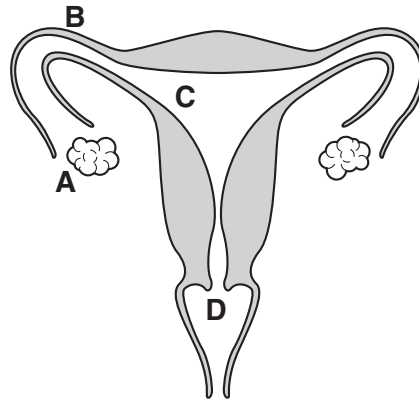

14 The diagram shows four processes, W, X, Y and Z that form part of the carbon cycle.

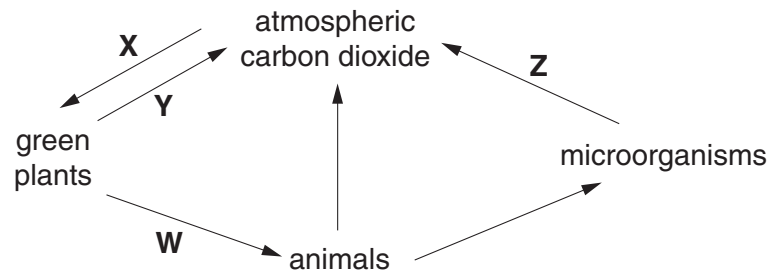

Which two processes represent respiration?

- A W and X
- B X and Y
- C Y and Z
- D Z and W

- 15 On heating iron and sulphur together, the mixture starts to glow. The glow then continues even when the heating is stopped.

In this reaction,**X**..... heat is given out and a new**Y**..... is formed.

What are words **X** and **Y**?

	X	Y
A	no	element
B	no	compound
C	some	element
D	some	compound

- 16 Which material is the main source of the molecules that are used to make most plastics?

- A** air
- B** coal
- C** limestone
- D** petroleum

- 17 The apparatus shown can be used to test a property of compound **R**.

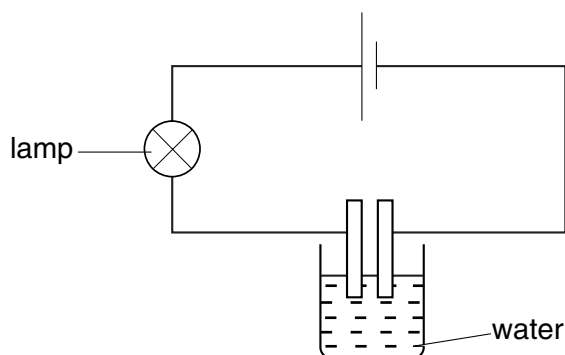

When compound **R** is dissolved in the water, the lamp lights.

Which statements about **R** are correct?

	type of bonding	elements in compound
A	covalent	a metal and a non-metal
B	covalent	non-metals only
C	ionic	a metal and a non-metal
D	ionic	non-metals only

22 The diagrams show an experiment.

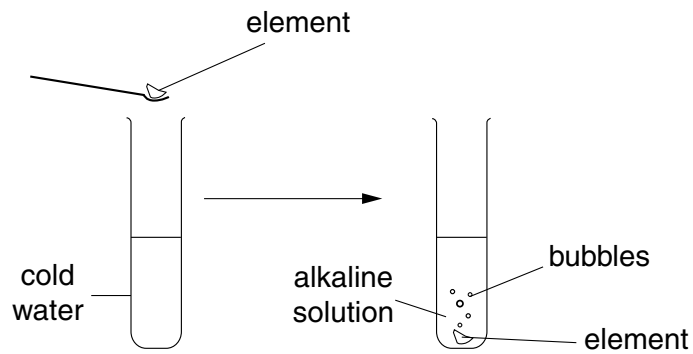

What could the element be?

- A calcium
- B carbon
- C iron
- D sulphur

23 A student wants to make magnesium nitrate by reacting magnesium oxide with an acid.

What is the formula of the acid he should use?

- A NH_3
- B NO_2
- C HNO_2
- D HNO_3

- 24 The diagram shows what happens when damp red litmus paper is placed into two different gases, **X** and **Y**.

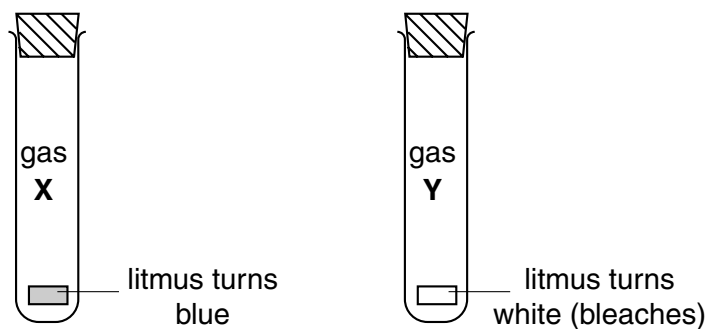

What are gases **X** and **Y**?

	X	Y
A	ammonia	carbon dioxide
B	ammonia	chlorine
C	chlorine	ammonia
D	chlorine	carbon dioxide

- 25 The diagram shows wood burning.

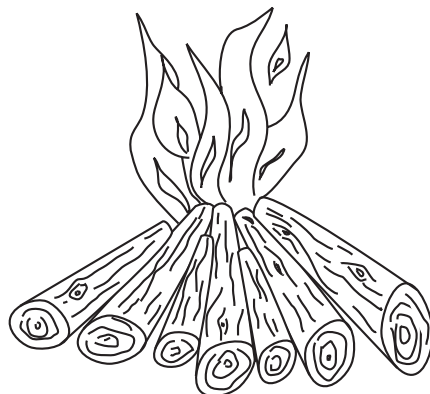

Which description of wood burning is correct?

- A** Both oxidation and reduction occur.
- B** Only decomposition occurs.
- C** Only oxidation occurs.
- D** Only reduction occurs.

26 A solution is tested for the presence of cations.

test	result
adding an excess of aqueous ammonia	green precipitate

Which cation is present?

- A Cu^{2+}
- B Fe^{2+}
- C Fe^{3+}
- D Zn^{2+}

27 When substance **X** burns, two products form.

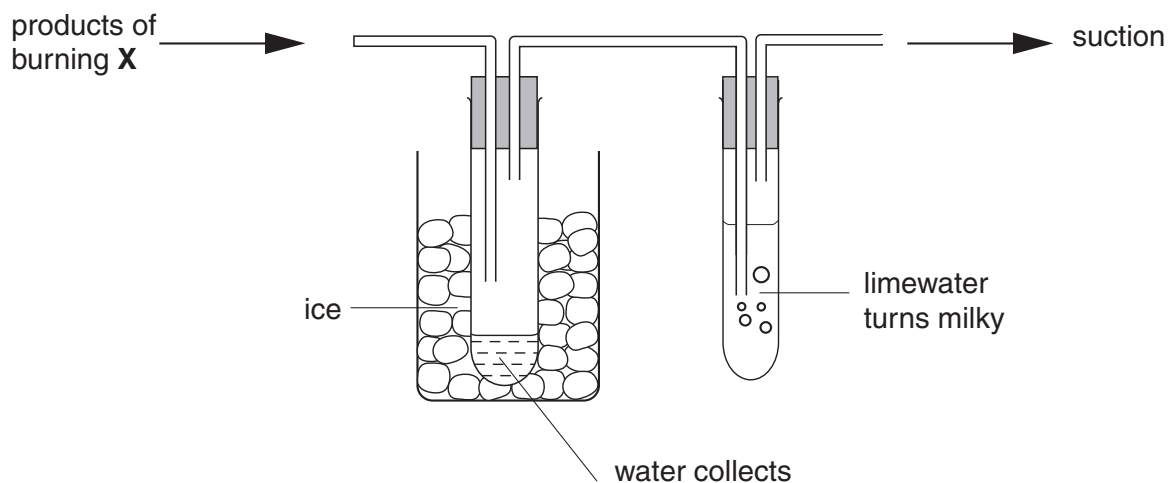

What is **X**?

- A carbon monoxide, CO
- B ethane, C_2H_6
- C hydrogen, H_2
- D sulphur, S

- 28 Which of the following is **not** necessary when using a measuring cylinder to measure the volume of a quantity of water?
- A making sure that the measuring cylinder is vertical
 - B making sure that your eye is level with the liquid surface
 - C reading the bottom of the meniscus
 - D using the largest measuring cylinder possible
- 29 Five telegraph poles are positioned at equal distances along the side of a road.

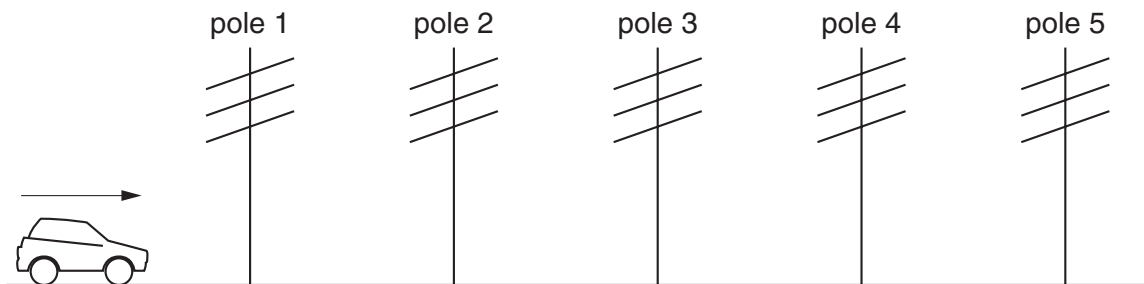

A car accelerates until it is level with pole 4. The car then continues along the road at a steady speed. The times taken to travel between one pole and the next are measured.

Which time is the greatest?

The time between

- A pole 1 and pole 2.
 - B pole 2 and pole 3.
 - C pole 3 and pole 4.
 - D pole 4 and pole 5.
- 30 A student tries to find the density of a metal block. First he measures the weight with a forcemeter (spring balance). Next he measures the sides of the block using a rule, in order to calculate the volume of the block. Finally he divides the weight by the volume to find the density.

The student has made a mistake.

Why does his method **not** give the density?

- A Density is volume divided by weight.
- B He should have measured the surface area, not the volume.
- C He should have used the mass in his calculation, not the weight.
- D Weight is not measured with a forcemeter (spring balance).

- 31 A tidal power station is made by building a barrage across the mouth of a river. At high tide the sea water is trapped behind the barrage.

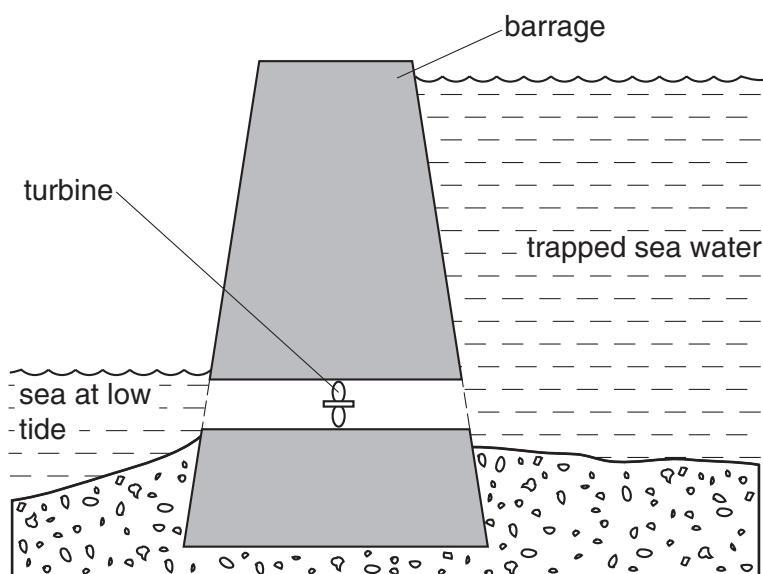

At low tide the water is allowed to flow back into the sea through a turbine.

What is the useful energy change in a tidal power station?

- A electrical energy \rightarrow energy of position (potential)
 - B electrical energy \rightarrow energy of motion (kinetic)
 - C energy of motion (kinetic) \rightarrow energy of position (potential)
 - D energy of position (potential) \rightarrow electrical energy
- 32 There is a vacuum between the double walls of a vacuum flask.

Which types of heat transfer are reduced by the vacuum?

- A conduction and convection
- B conduction and radiation
- C convection and radiation
- D conduction, convection and radiation

33 Waves travel more slowly on the surface of water when the water is shallow.

A person drops a stone into a pool at **X**. The diagram shows the first wavefront on the surface of the pool.

Which region of the pool is likely to be most shallow?

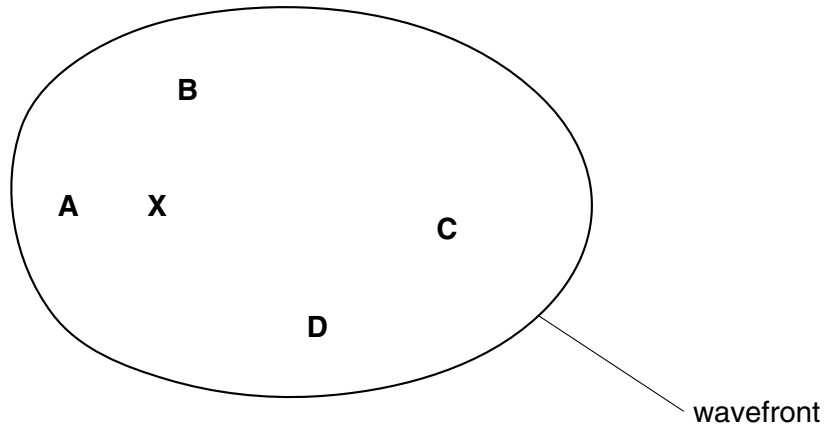

34 Which diagram shows the correct order of the waves in the electromagnetic spectrum?

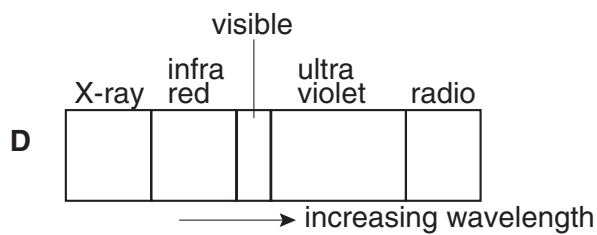
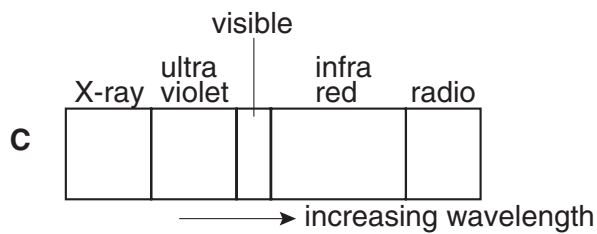
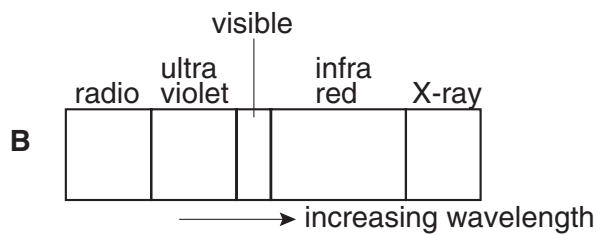
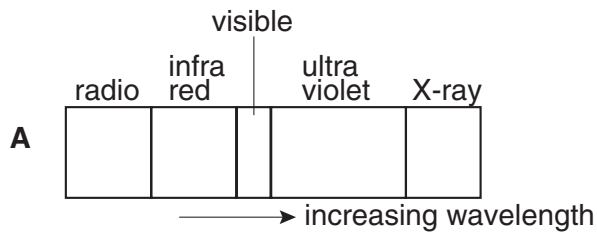

- 35 Astronaut 1 uses a hammer to mend a satellite in space. Astronaut 2 is nearby. There is no atmosphere in space.

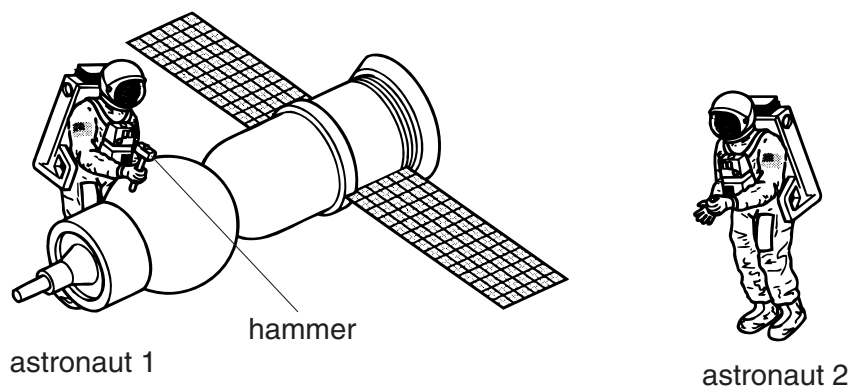

Compared with the sound heard if they were working on Earth, what does astronaut 2 hear?

- A no sound at all
 - B a quieter sound
 - C a sound of the same loudness
 - D a louder sound
- 36 A student wants to find the resistance of resistor R using a voltmeter and an ammeter.

Which circuit should the student use?

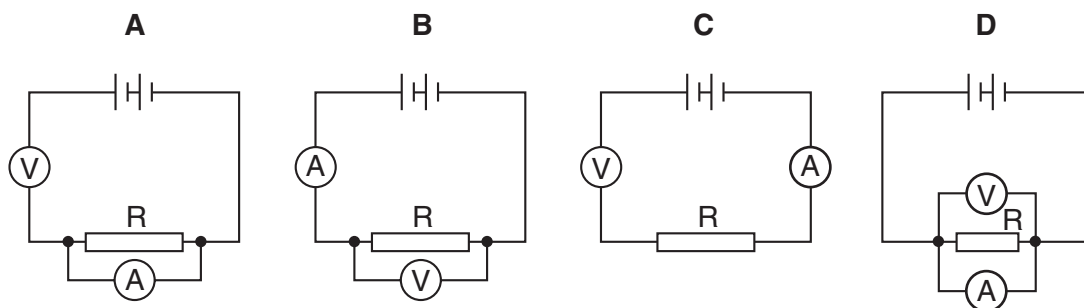

- 37 Four students are asked to draw a circuit showing three lamps working in parallel, a cell, and a switch that controls all three lamps.

Which student is correct?

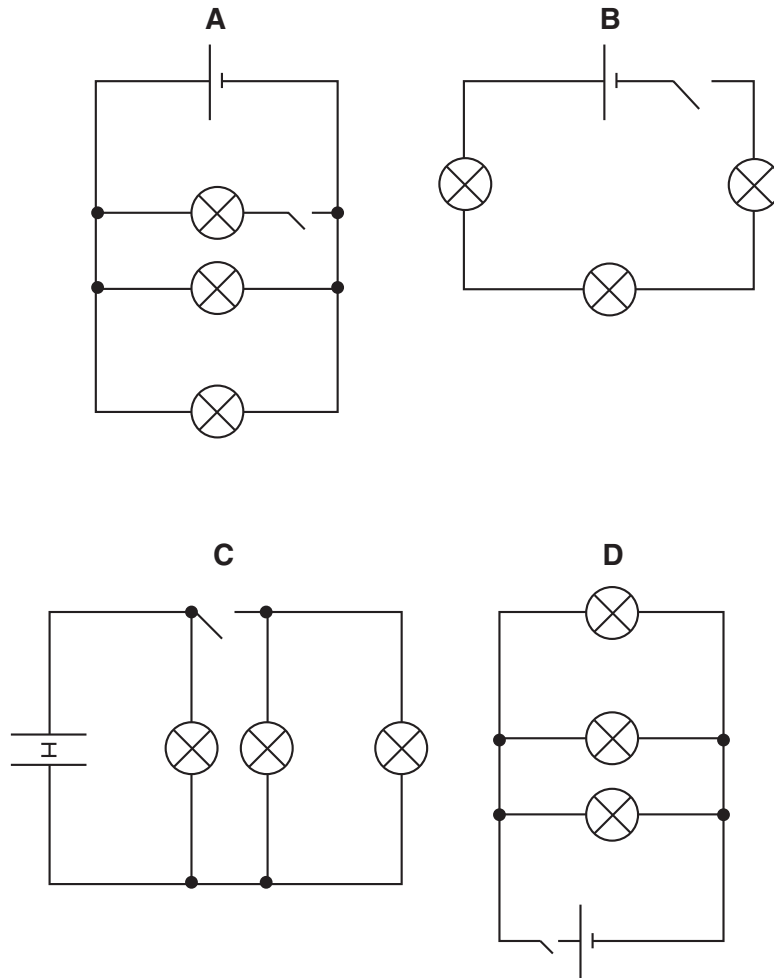

- 38 A $3.0\ \Omega$ lamp and a $6.0\ \Omega$ lamp are connected in series.

What is the total resistance of the combination?

- A $0.5\ \Omega$
- B $2.0\ \Omega$
- C $9.0\ \Omega$
- D $18.0\ \Omega$

39 How is electricity transmitted over large distances and why is it transmitted in this way?

	how	why
A	at high voltage	for safety
B	at high voltage	to reduce energy loss
C	at low voltage	for safety
D	at low voltage	to reduce energy loss

40 Which line in the table describes the nature of an α -particle and a γ -ray?

	α -particle	γ -ray
A	helium nucleus	electromagnetic radiation
B	helium nucleus	electron
C	proton	electromagnetic radiation
D	proton	electron

DATA SHEET
The Periodic Table of the Elements
Group

I	II	III	IV	V	VI	VII	O	
7 Li Lithium 3	9 Be Beryllium 4	1 H Hydrogen 1					4 He Helium 2	
23 Na Sodium 11	24 Mg Magnesium 12	11 B Boron 5	12 C Carbon 6	14 N Nitrogen 7	16 O Oxygen 8	19 F Fluorine 9	20 Ne Neon 10	
39 K Potassium 19	40 Ca Calcium 20	27 Al Aluminium 13	28 Si Silicon 14	31 P Phosphorus 15	32 S Sulphur 16	35.5 Cl Chlorine 17	40 Ar Argon 18	
85 Rb Rubidium 37	88 Sr Strontium 38	70 Ga Gallium 31	73 Ge Germanium 32	75 As Arsenic 33	79 Se Selenium 34	80 Br Bromine 35	84 Kr Krypton 36	
133 Cs Caesium 55	137 Ba Barium 56	65 Zn Zinc 30	64 Cu Copper 29	106 Pd Palladium 46	108 Ag Silver 47	127 I Iodine 53	131 Xe Xenon 54	
226 Ra Radium 88	227 Ac Actinium 89	59 Co Cobalt 27	59 Ni Nickel 28	103 Rh Rhodium 45	106 Pd Palladium 46	209 Po Polonium 84	210 At Astatine 85	
		55 Mn Manganese 25	56 Fe Iron 26	101 Ru Ruthenium 44	101 Ru Ruthenium 44	204 Pb Lead 82	204 Pb Lead 82	
		52 Cr Chromium 24	55 Mn Manganese 25	103 Rh Rhodium 45	106 Pd Palladium 46	207 Pb Lead 82	207 Pb Lead 82	
		51 V Vanadium 23	56 Fe Iron 26	103 Rh Rhodium 45	106 Pd Palladium 46	209 Hg Mercury 80	209 Hg Mercury 80	
		48 Ti Titanium 22	56 Fe Iron 26	101 Ru Ruthenium 44	108 Ag Silver 47	112 Cd Cadmium 48	112 Cd Cadmium 48	
		41 Nb Niobium 41	56 Fe Iron 26	101 Ru Ruthenium 44	108 Ag Silver 47	115 In Indium 49	115 In Indium 49	
		91 Zr Zirconium 40	56 Fe Iron 26	101 Ru Ruthenium 44	108 Ag Silver 47	119 Sn Tin 50	119 Sn Tin 50	
		78 Hf Hafnium 72	56 Fe Iron 26	101 Ru Ruthenium 44	108 Ag Silver 47	122 Sb Antimony 51	122 Sb Antimony 51	
		139 La Lanthanum 57	56 Fe Iron 26	101 Ru Ruthenium 44	108 Ag Silver 47	209 Bi Bismuth 83	209 Bi Bismuth 83	
		181 Ta Tantalum 73	56 Fe Iron 26	101 Ru Ruthenium 44	108 Ag Silver 47	209 Po Polonium 84	209 Po Polonium 84	
		178 Hf Hafnium 72	56 Fe Iron 26	101 Ru Ruthenium 44	108 Ag Silver 47	209 Pb Lead 82	209 Pb Lead 82	
		184 W Tungsten 74	56 Fe Iron 26	101 Ru Ruthenium 44	108 Ag Silver 47	209 Hg Mercury 80	209 Hg Mercury 80	
		184 W Tungsten 74	56 Fe Iron 26	101 Ru Ruthenium 44	108 Ag Silver 47	209 Hg Mercury 80	209 Hg Mercury 80	
		141 Pr Praseodymium 59	56 Fe Iron 26	101 Ru Ruthenium 44	108 Ag Silver 47	159 Tb Terbium 65	159 Tb Terbium 65	
		144 Nd Neodymium 60	56 Fe Iron 26	101 Ru Ruthenium 44	108 Ag Silver 47	162 Dy Dysprosium 66	162 Dy Dysprosium 66	
		141 Pr Praseodymium 59	56 Fe Iron 26	101 Ru Ruthenium 44	108 Ag Silver 47	167 Er Erbium 68	167 Er Erbium 68	
		144 Nd Neodymium 60	56 Fe Iron 26	101 Ru Ruthenium 44	108 Ag Silver 47	173 Yb Ytterbium 70	173 Yb Ytterbium 70	
		141 Pr Praseodymium 59	56 Fe Iron 26	101 Ru Ruthenium 44	108 Ag Silver 47	181 Lu Lutetium 71	181 Lu Lutetium 71	
		144 Nd Neodymium 60	56 Fe Iron 26	101 Ru Ruthenium 44	108 Ag Silver 47	187 Tm Thulium 69	187 Tm Thulium 69	
		141 Pr Praseodymium 59	56 Fe Iron 26	101 Ru Ruthenium 44	108 Ag Silver 47	194 Sm Samarium 62	194 Sm Samarium 62	
		144 Nd Neodymium 60	56 Fe Iron 26	101 Ru Ruthenium 44	108 Ag Silver 47	201 Er Erbium 68	201 Er Erbium 68	
		141 Pr Praseodymium 59	56 Fe Iron 26	101 Ru Ruthenium 44	108 Ag Silver 47	209 Fm Fermium 100	209 Fm Fermium 100	
		144 Nd Neodymium 60	56 Fe Iron 26	101 Ru Ruthenium 44	108 Ag Silver 47	210 Md Mendelevium 101	210 Md Mendelevium 101	
		141 Pr Praseodymium 59	56 Fe Iron 26	101 Ru Ruthenium 44	108 Ag Silver 47	210 No Nobelium 102	210 No Nobelium 102	
		144 Nd Neodymium 60	56 Fe Iron 26	101 Ru Ruthenium 44	108 Ag Silver 47	210 Lr Lawrencium 103	210 Lr Lawrencium 103	
		141 Pr Praseodymium 59	56 Fe Iron 26	101 Ru Ruthenium 44	108 Ag Silver 47	210 Lr Lawrencium 103	210 Lr Lawrencium 103	
		144 Nd Neodymium 60	56 Fe Iron 26	101 Ru Ruthenium 44	108 Ag Silver 47	210 Lr Lawrencium 103	210 Lr Lawrencium 103	
		141 Pr Praseodymium 59	56 Fe Iron 26	101 Ru Ruthenium 44	108 Ag Silver 47	210 Lr Lawrencium 103	210 Lr Lawrencium 103	
		144 Nd Neodymium 60	56 Fe Iron 26	101 Ru Ruthenium 44	108 Ag Silver 47	210 Lr Lawrencium 103	210 Lr Lawrencium 103	
		141 Pr Praseodymium 59	56 Fe Iron 26	101 Ru Ruthenium 44	108 Ag Silver 47	210 Lr Lawrencium 103	210 Lr Lawrencium 103	
		144 Nd Neodymium 60	56 Fe Iron 26	101 Ru Ruthenium 44	108 Ag Silver 47	210 Lr Lawrencium 103	210 Lr Lawrencium 103	
		141 Pr Praseodymium 59	56 Fe Iron 26	101 Ru Ruthenium 44	108 Ag Silver 47	210 Lr Lawrencium 103	210 Lr Lawrencium 103	
		144 Nd Neodymium 60	56 Fe Iron 26	101 Ru Ruthenium 44	108 Ag Silver 47	210 Lr Lawrencium 103	210 Lr Lawrencium 103	
		141 Pr Praseodymium 59	56 Fe Iron 26	101 Ru Ruthenium 44	108 Ag Silver 47	210 Lr Lawrencium 103	210 Lr Lawrencium 103	
		144 Nd Neodymium 60	56 Fe Iron 26	101 Ru Ruthenium 44	108 Ag Silver 47	210 Lr Lawrencium 103	210 Lr Lawrencium 103	
		141 Pr Praseodymium 59	56 Fe Iron 26	101 Ru Ruthenium 44	108 Ag Silver 47	210 Lr Lawrencium 103	210 Lr Lawrencium 103	
		144 Nd Neodymium 60	56 Fe Iron 26	101 Ru Ruthenium 44	108 Ag Silver 47	210 Lr Lawrencium 103	210 Lr Lawrencium 103	
		141 Pr Praseodymium 59	56 Fe Iron 26	101 Ru Ruthenium 44	108 Ag Silver 47	210 Lr Lawrencium 103	210 Lr Lawrencium 103	
		144 Nd Neodymium 60	56 Fe Iron 26	101 Ru Ruthenium 44	108 Ag Silver 47	210 Lr Lawrencium 103	210 Lr Lawrencium 103	
		141 Pr Praseodymium 59	56 Fe Iron 26	101 Ru Ruthenium 44	108 Ag Silver 47	210 Lr Lawrencium 103	210 Lr Lawrencium 103	
		144 Nd Neodymium 60	56 Fe Iron 26	101 Ru Ruthenium 44	108 Ag Silver 47	210 Lr Lawrencium 103	210 Lr Lawrencium 103	
		141 Pr Praseodymium 59	56 Fe Iron 26	101 Ru Ruthenium 44	108 Ag Silver 47	210 Lr Lawrencium 103	210 Lr Lawrencium 103	
		144 Nd Neodymium 60	56 Fe Iron 26	101 Ru Ruthenium 44	108 Ag Silver 47	210 Lr Lawrencium 103	210 Lr Lawrencium 103	
		141 Pr Praseodymium 59	56 Fe Iron 26	101 Ru Ruthenium 44	108 Ag Silver 47	210 Lr Lawrencium 103	210 Lr Lawrencium 103	
		144 Nd Neodymium 60	56 Fe Iron 26	101 Ru Ruthenium 44	108 Ag Silver 47	210 Lr Lawrencium 103	210 Lr Lawrencium 103	
		141 Pr Praseodymium 59	56 Fe Iron 26	101 Ru Ruthenium 44	108 Ag Silver 47	210 Lr Lawrencium 103	210 Lr Lawrencium 103	
		144 Nd Neodymium 60	56 Fe Iron 26	101 Ru Ruthenium 44	108 Ag Silver 47	210 Lr Lawrencium 103	210 Lr Lawrencium 103	
		141 Pr Praseodymium 59	56 Fe Iron 26	101 Ru Ruthenium 44	108 Ag Silver 47	210 Lr Lawrencium 103	210 Lr Lawrencium 103	
		144 Nd Neodymium 60	56 Fe Iron 26	101 Ru Ruthenium 44	108 Ag Silver 47	210 Lr Lawrencium 103	210 Lr Lawrencium 103	
		141 Pr Praseodymium 59	56 Fe Iron 26	101 Ru Ruthenium 44	108 Ag Silver 47	210 Lr Lawrencium 103	210 Lr Lawrencium 103	
		144 Nd Neodymium 60	56 Fe Iron 26	101 Ru Ruthenium 44	108 Ag Silver 47	210 Lr Lawrencium 103	210 Lr Lawrencium 103	
		141 Pr Praseodymium 59	56 Fe Iron 26	101 Ru Ruthenium 44	108 Ag Silver 47	210 Lr Lawrencium 103	210 Lr Lawrencium 103	
		144 Nd Neodymium 60	56 Fe Iron 26	101 Ru Ruthenium 44	108 Ag Silver 47	210 Lr Lawrencium 103	210 Lr Lawrencium 103	
		141 Pr Praseodymium 59	56 Fe Iron 26	101 Ru Ruthenium 44	108 Ag Silver 47	210 Lr Lawrencium 103	210 Lr Lawrencium 103	
		144 Nd Neodymium 60	56 Fe Iron 26	101 Ru Ruthenium 44	108 Ag Silver 47	210 Lr Lawrencium 103	210 Lr Lawrencium 103	
		141 Pr Praseodymium 59	56 Fe Iron 26	101 Ru Ruthenium 44	108 Ag Silver 47	210 Lr Lawrencium 103	210 Lr Lawrencium 103	
		144 Nd Neodymium 60	56 Fe Iron 26	101 Ru Ruthenium 44	108 Ag Silver 47	210 Lr Lawrencium 103	210 Lr Lawrencium 103	
		141 Pr Praseodymium 59	56 Fe Iron 26	101 Ru Ruthenium 44	108 Ag Silver 47	210 Lr Lawrencium 103	210 Lr Lawrencium 103	
		144 Nd Neodymium 60	56 Fe Iron 26	101 Ru Ruthenium 44	108 Ag Silver 47	210 Lr Lawrencium 103	210 Lr Lawrencium 103	
		141 Pr Praseodymium 59	56 Fe Iron 26	101 Ru Ruthenium 44	108 Ag Silver 47	210 Lr Lawrencium 103	210 Lr Lawrencium 103	
		144 Nd Neodymium 60	56 Fe Iron 26	101 Ru Ruthenium 44	108 Ag Silver 47	210 Lr Lawrencium 103	210 Lr Lawrencium 103	
		141 Pr Praseodymium 59	56 Fe Iron 26	101 Ru Ruthenium 44	108 Ag Silver 47	210 Lr Lawrencium 103	210 Lr Lawrencium 103	
		144 Nd Neodymium 60	56 Fe Iron 26	101 Ru Ruthenium 44	108 Ag Silver 47	210 Lr Lawrencium 103	210 Lr Lawrencium 103	
		141 Pr Praseodymium 59	56 Fe Iron 26	101 Ru Ruthenium 44	108 Ag Silver 47	210 Lr Lawrencium 103	210 Lr Lawrencium 103	
		144 Nd Neodymium 60	56 Fe Iron 26	101 Ru Ruthenium 44	108 Ag Silver 47	210 Lr Lawrencium 103	210 Lr Lawrencium 103	
		141 Pr Praseodymium 59	56 Fe Iron 26	101 Ru Ruthenium 44	108 Ag Silver 47	210 Lr Lawrencium 103	210 Lr Lawrencium 103	
		144 Nd Neodymium						