



UNIVERSITY OF CAMBRIDGE INTERNATIONAL EXAMINATIONS  
International General Certificate of Secondary Education

CANDIDATE  
NAME

CENTRE  
NUMBER

--	--	--	--	--

CANDIDATE  
NUMBER

--	--	--	--

\* 5 8 2 1 5 2 9 5 1 3 \*

**COMBINED SCIENCE**

**0653/52**

Paper 5 Practical Test

**May/June 2012**

**1 hour 30 minutes**

Candidates answer on the Question Paper.

Additional Materials: As listed in Instructions to Supervisors.

**READ THESE INSTRUCTIONS FIRST**

Write your Centre number, candidate number and name on all the work you hand in.

Write in dark blue or black pen.

You may use a pencil for any diagrams, graphs or rough working.

Do not use staples, paper clips, highlighters, glue or correction fluid.

**DO NOT WRITE IN ANY BARCODES.**

Answer **all** questions.

Chemistry practical notes for this paper are printed on page 12.

At the end of the examination, fasten all your work securely together.

The number of marks is given in brackets [ ] at the end of each question or part question.

For Examiner's Use	
<b>1</b>	
<b>2</b>	
<b>3</b>	
<b>Total</b>	

This document consists of **10** printed pages and **2** blank pages.



1 You are going to investigate the digestion of fat in milk by the action of the enzyme lipase.

For  
Examiner's  
Use

- (a)
- Half fill a 500 cm<sup>3</sup> beaker with the hot and cold water provided to make a water bath with a temperature between 35 °C and 40 °C. It may be necessary to add more hot water to maintain this temperature range.
  - Using a measuring cylinder, place 7 cm<sup>3</sup> of sodium carbonate solution into each of tubes **A** and **B**.
  - Using a measuring cylinder, place 5 cm<sup>3</sup> of full fat milk into each of tubes **A** and **B**.
  - Place 5 drops of phenolphthalein indicator solution into each of tubes **A** and **B**.
  - Place both tubes into the water bath and leave them for 10 minutes, remembering to maintain the temperature range as above.

**During this 10 minutes continue with part (e).**

- After 10 minutes, using a syringe, add 1 cm<sup>3</sup> **boiled** lipase solution to tube **A** and mix. Immediately, using a syringe, add 1 cm<sup>3</sup> of **unboiled** lipase to tube **B** and mix. Leave both tubes in the water bath.
- Start the timer.
- Record in Table 1.1 the time taken, in seconds, for the pink colour of the mixtures to disappear. If no colour change has occurred after 10 minutes, record 'no change'.

**Table 1.1**

tube	<b>A</b>	<b>B</b>
lipase	boiled	unboiled
time taken for pink colour to disappear / s		

[3]

- (b) Lipase breaks down fat into fatty acids. Sodium carbonate is a weak alkali. Phenolphthalein is an indicator. If the solution has a pH of above 8, it is pink. If the pH is less than 8, it is colourless.

If any of the solutions turned from pink to colourless, suggest and explain why the solution changed colour.

.....  
 .....  
 .....

[2]

(c) Suggest and explain how the results indicate that lipase is an enzyme.

.....  
 .....  
 ..... [2]

(d) Suggest **one** source of error in the experiment.

.....  
 ..... [1]

- (e) • Using a measuring cylinder, place 5 cm<sup>3</sup> of fresh full fat milk into tube **C**.  
 • Using a measuring cylinder, place 5 cm<sup>3</sup> of biuret reagent into tube **C** and mix. Record in Table 1.2 the colour of the resulting solution and suggest a reason for the colour.

**Table 1.2**

tube	C
colour of solution	
reason for colour	

[2]

For  
Examiner's  
Use

- 2 You are going to find the density of a material used to make plastic pipes. You will use two different methods to find the volume of the piece of pipe.

(a) (i) Use the balance provided to find the mass in grams, **M**, of your piece of plastic pipe.

Record your answer to 1 decimal place.

**M** = ..... g [1]

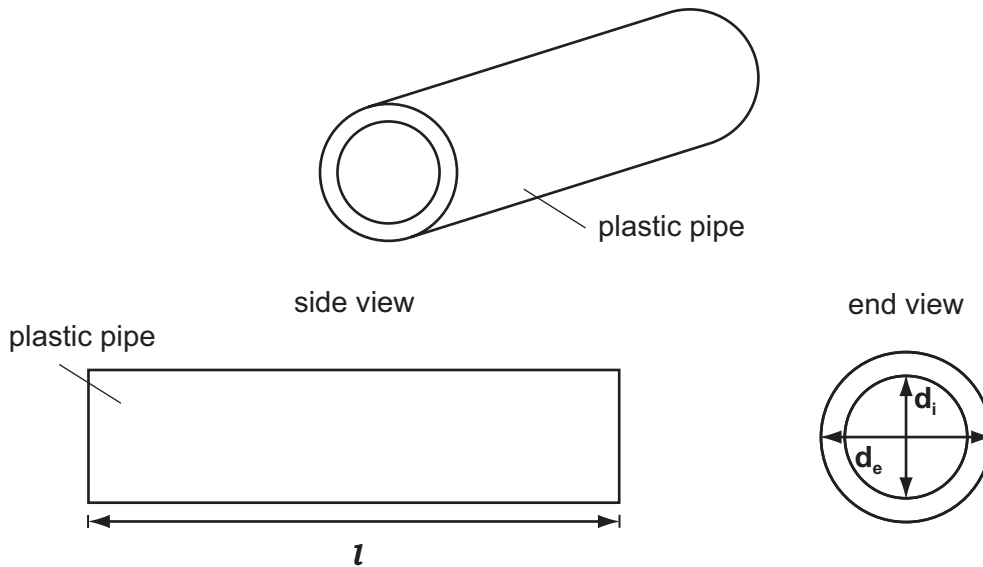

Fig. 2.1

(ii) **Method 1**

Measure the length, **l**, the external diameter, **d<sub>e</sub>**, and the internal diameter, **d<sub>i</sub>**, in centimetres as shown in Fig. 2.1, of your piece of plastic pipe.

Record your measurements below.

length, **l** = .....

external diameter, **d<sub>e</sub>** = .....

internal diameter, **d<sub>i</sub>** = ..... [1]

(iii) Use your values of external and internal diameters, in cm, to calculate **k** from the formula below.

$$k = d_e^2 - d_i^2$$

**k** = ..... cm<sup>2</sup> [2]

- (iv) Use your values in (a)(ii) and (a)(iii) to calculate the volume  $V$ , in  $\text{cm}^3$ , of the piece of pipe using the formula below.

$$V = \frac{\pi k l}{4}$$

volume,  $V =$  .....  $\text{cm}^3$  [1]

- (v) Use your values in (a)(i) and (a)(iv) to calculate the density of the plastic in this piece of pipe, using the formula below.

$$\text{density} = \frac{M}{V}$$

(method 1) density of plastic = .....  $\text{g}/\text{cm}^3$  [1]

For  
Examiner's  
Use

**(b) (i) Method 2**

Exactly fill the  $250\text{ cm}^3$  measuring cylinder with water up to the  $150\text{ cm}^3$  mark. Attach the thread to the metal weight and lower it into the water until it is fully immersed.

Read the new water level in the measuring cylinder and record the volume reading in Table 2.1. [1]

**Table 2.1**

	volume / $\text{cm}^3$
<b>water and metal weight</b>	
<b>water, metal weight and piece of pipe</b>	

- (ii) Remove the metal weight from the water, dry with a paper towel, and attach it to the piece of plastic pipe using the thread. If necessary, adjust the volume of water in the measuring cylinder to read exactly  $150\text{ cm}^3$ .

Carefully lower the metal weight and piece of pipe into the water in the measuring cylinder until they are both fully immersed as in Fig. 2.2.

Read the new water level in the measuring cylinder and record the volume reading in Table 2.1.

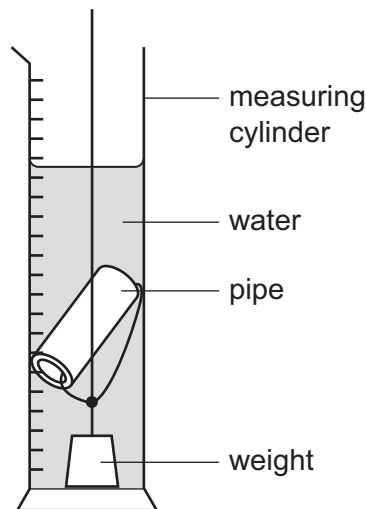
**Fig. 2.2**

[1]

- (iii) Using the volume readings in Table 2.1, calculate the volume of the material in the piece of pipe.

For  
Examiner's  
Use

volume of material in pipe = ..... cm<sup>3</sup> [1]

- (iv) Use your values in (a)(i) and (b)(iii) to calculate the density of the plastic in this piece of pipe.

(method 2) density of plastic = ..... g/cm<sup>3</sup> [1]

3 You are going to find out how much heat is produced in the reaction between solid **A** and solution **B**.

For  
Examiner's  
Use

(a) (i) Using the thermometer measure the temperature of solution **B**. Record the value to the nearest half degree, in Table 3.1 in the appropriate space, for time = 0 min. [1]

**Table 3.1**

time / min	temperature / °C
0	
0.5	
1.0	
1.5	
2.0	
2.5	
3.0	
3.5	
4.0	
4.5	
5.0	
5.5	
6.0	
6.5	
7.0	

(ii) • Place all of the solid **A** into the plastic cup.  
 • Using the measuring cylinder measure out 25cm<sup>3</sup> of solution **B**. Add this quickly to solid **A** in the plastic cup. Start the stopclock.  
 • Stir the mixture thoroughly.  
 • Measure the temperature of the mixture every half minute for seven minutes, stirring throughout and recording the values to the nearest half degree in Table 3.1. [2]

(iii) Record any changes to the appearance of the solid and to the solution in Table 3.2.

**Table 3.2**

observations	solid A	solution B
before the reaction	grey	blue
after the reaction		

[2]



- (b) (i) Using the data in Table 3.1, plot a graph of temperature (vertical axis) against time on the grid provided. Draw a smooth curve through the points.

For  
Examiner's  
Use

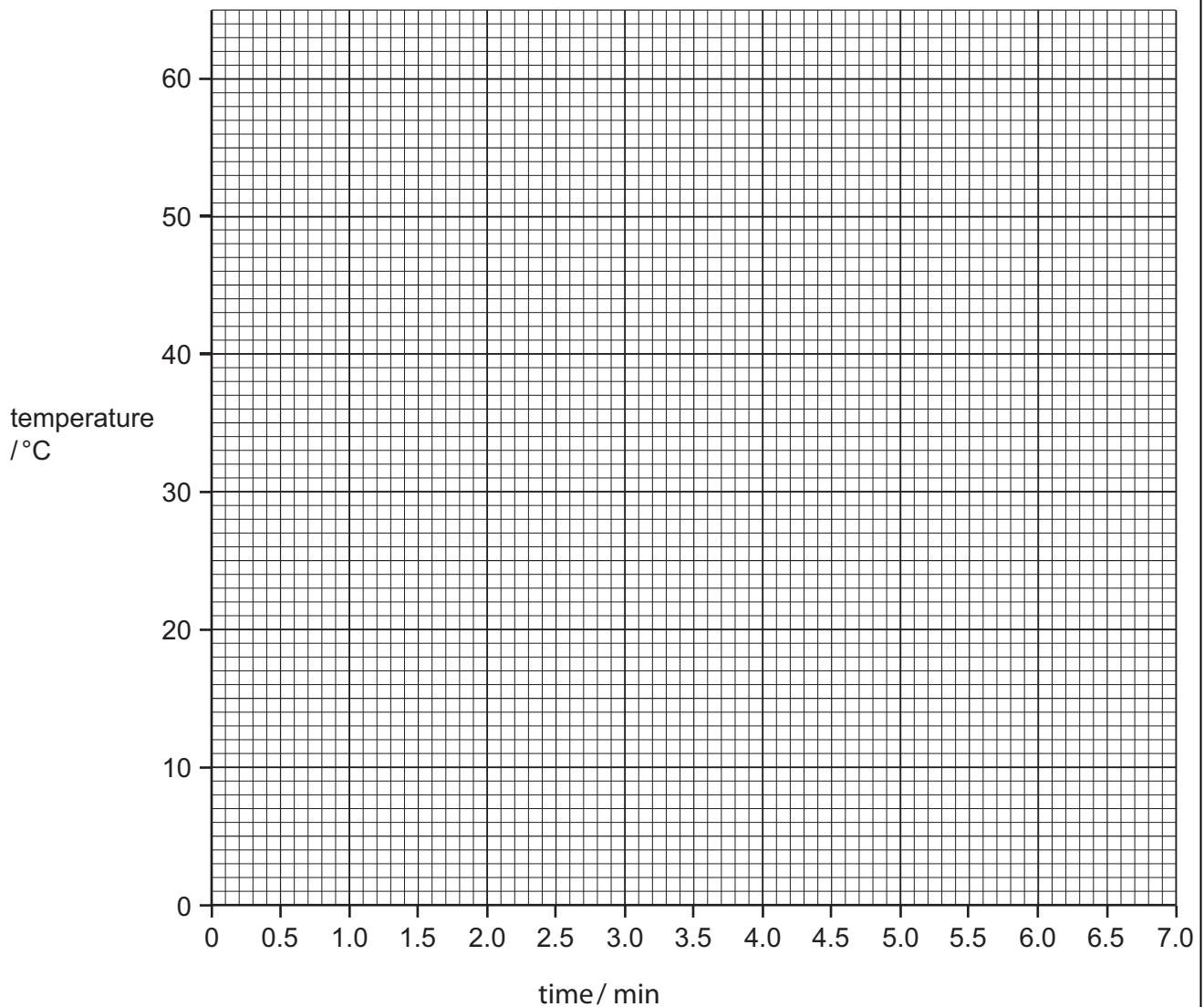

[2]

- (ii) Use your graph to find the maximum temperature **rise**,  $\Delta T$ , in this reaction.

$$\Delta T = \text{.....} \text{ } ^\circ\text{C} \quad [1]$$

- (iii) Calculate **E**, the energy given out by the reaction using the formula below.

$$E = \text{volume of solution } \mathbf{B} \times 4.2 \times \Delta T$$

$$E = \text{.....} \text{ J} \quad [2]$$





## CHEMISTRY PRACTICAL NOTES

## Test for anions

<i>anion</i>	<i>test</i>	<i>test result</i>
carbonate ( $\text{CO}_3^{2-}$ )	add dilute acid	effervescence, carbon dioxide produced
chloride ( $\text{Cl}^-$ ) [in solution]	acidify with dilute nitric acid, then add aqueous silver nitrate	white ppt.
nitrate ( $\text{NO}_3^-$ ) [in solution]	add aqueous sodium hydroxide then aluminium foil; warm carefully	ammonia produced
sulfate ( $\text{SO}_4^{2-}$ ) [in solution]	acidify then add aqueous barium chloride <i>or</i> aqueous barium nitrate	white ppt.

## Test for aqueous cations

<i>cation</i>	<i>effect of aqueous sodium hydroxide</i>	<i>effect of aqueous ammonia</i>
ammonium ( $\text{NH}_4^+$ )	ammonia produced on warming	-
copper(II) ( $\text{Cu}^{2+}$ )	light blue ppt., insoluble in excess	light blue ppt., soluble in excess giving a dark blue solution
iron(II) ( $\text{Fe}^{2+}$ )	green ppt., insoluble in excess	green ppt., insoluble in excess
iron(III) ( $\text{Fe}^{3+}$ )	red-brown ppt., insoluble in excess	red-brown ppt., insoluble in excess
zinc ( $\text{Zn}^{2+}$ )	white ppt., soluble in excess giving a colourless solution	white ppt., soluble in excess giving a colourless solution

## Test for gases

<i>gas</i>	<i>test and test results</i>
ammonia ( $\text{NH}_3$ )	turns damp red litmus paper blue
carbon dioxide ( $\text{CO}_2$ )	turns limewater milky
chlorine ( $\text{Cl}_2$ )	bleaches damp litmus paper
hydrogen ( $\text{H}_2$ )	"pops" with a lighted splint
oxygen ( $\text{O}_2$ )	relights a glowing splint

Permission to reproduce items where third-party owned material protected by copyright is included has been sought and cleared where possible. Every reasonable effort has been made by the publisher (UCLES) to trace copyright holders, but if any items requiring clearance have unwittingly been included, the publisher will be pleased to make amends at the earliest possible opportunity.

University of Cambridge International Examinations is part of the Cambridge Assessment Group. Cambridge Assessment is the brand name of University of Cambridge Local Examinations Syndicate (UCLES), which is itself a department of the University of Cambridge.