



UNIVERSITY OF CAMBRIDGE INTERNATIONAL EXAMINATIONS
International General Certificate of Secondary Education

CANDIDATE
NAME

CENTRE
NUMBER

--	--	--	--	--

CANDIDATE
NUMBER

--	--	--	--

* 4 4 7 4 2 4 0 1 1 6 *

COMBINED SCIENCE

0653/33

Paper 3 (Extended)

May/June 2010

1 hour 15 minutes

Candidates answer on the Question Paper.

No Additional Materials are required.

READ THESE INSTRUCTIONS FIRST

Write your Centre number, candidate number and name on all the work you hand in.

Write in dark blue or black pen.

You may use a soft pencil for any diagrams, graphs, tables or rough working.

Do not use staples, paper clips, highlighters, glue or correction fluid.

DO NOT WRITE IN ANY BARCODES.

Answer **all** questions.

A copy of the Periodic Table is printed on page 20.

At the end of the examination, fasten all your work securely together.

The number of marks is given in brackets [] at the end of each question or part question.

For Examiner's Use	
1	
2	
3	
4	
5	
6	
7	
8	
9	
Total	

This document consists of **20** printed pages.



1 (a) Fig. 1.1 shows four fruits.

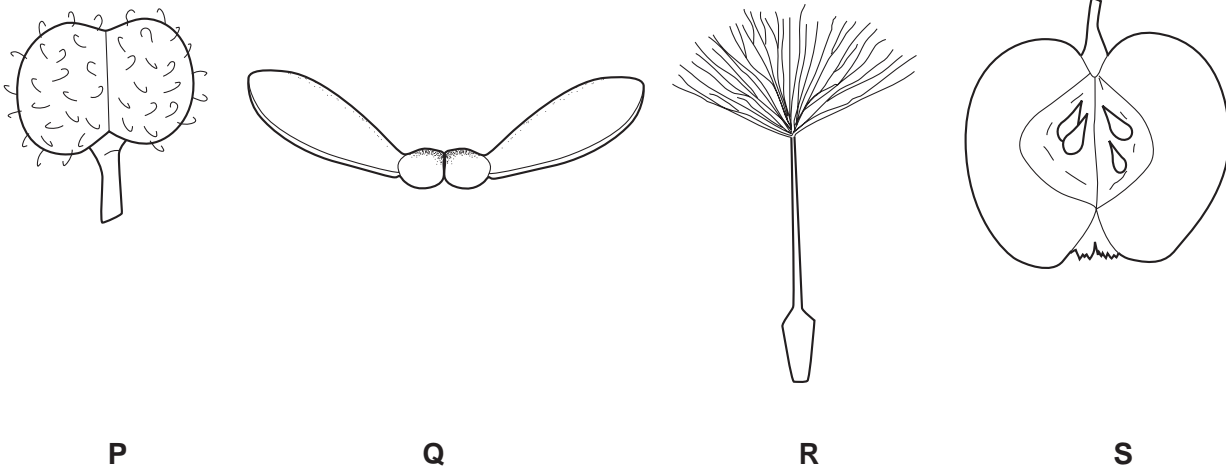

Fig. 1.1

(i) Give the letters of **two** fruits which are adapted for wind dispersal.

..... and [1]

(ii) Name the part of a flower from which the fruit develops. [1]

(iii) Explain the importance of fruits in the life cycle of a plant.

.....
.....
..... [2]

(b) Cacao trees produce many pink and white flowers from which the fruits develop. The seeds inside the pods (fruits) are used to make chocolate.

Wild cacao trees grow in rainforests in warm, humid climates. Most kinds of trees cultivated by humans, such as rubber trees or oil palms, grow best on cleared land, but cacao trees grow best underneath other rainforest trees. Most cacao trees are grown without the use of fertilisers or pesticides.

(i) Suggest how the flowers of the cacao tree are pollinated, giving a reason for your answer.

..... [1]

(ii) Explain why cultivating cacao trees may cause less damage to rainforests than cultivating other trees.

*For
Examiner's
Use*

.....

.....

.....

.....

.....

..... [3]

- 2 (a) A teacher placed a small piece of potassium into a container filled with chlorine gas.

Fig. 2.1 shows what the class observed.

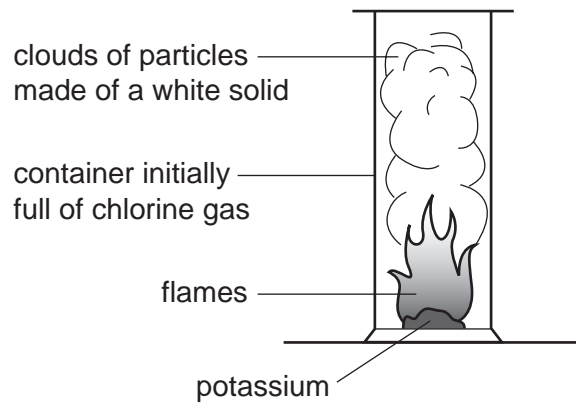

Fig. 2.1

- (i) Suggest the name of the white solid formed when potassium and chlorine react.

..... [1]

- (ii) Fig. 2.2 shows a potassium atom and a chlorine atom.

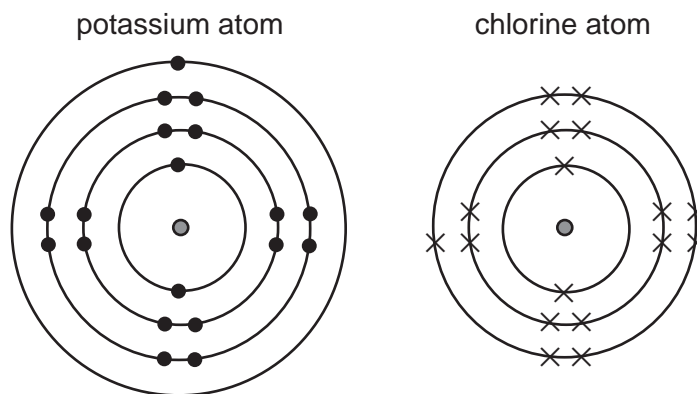

Fig. 2.2

Describe and explain, in terms of electronic structures, what happens when potassium and chlorine atoms react with each other. You may draw diagrams in the space below if it helps you to answer the question.

For
Examiner's
Use

.....
.....
.....
..... [4]

(b) Metallic potassium can be produced by electrolysis of molten potassium chloride. In this process, potassium forms at the cathode.

(i) Explain why potassium ions travel to the cathode and **not** the anode during electrolysis.

.....
.....
..... [1]

(ii) Describe, in terms of electrons, what happens when potassium ions collide with the surface of the cathode.

.....
.....
..... [2]

- 3 (a) Fig. 3.1 shows an astronaut on a space walk. His space suit is designed to stop dangerous electromagnetic radiation from the Sun reaching the astronaut's body.

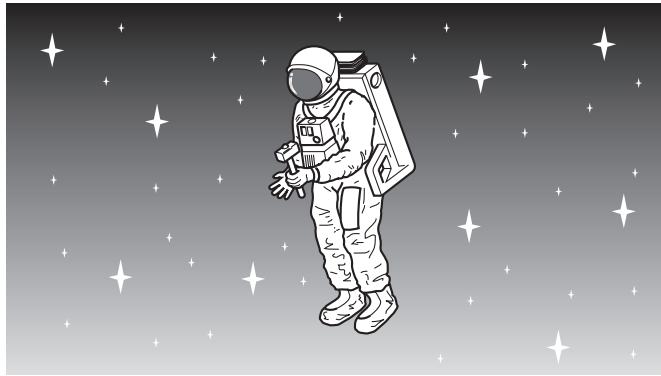

Fig. 3.1

- (i) Name **two** types of electromagnetic radiation that can harm the body.

1 2 [1]

- (ii) State **one** way in which electromagnetic radiation can harm the body.

..... [1]

- (iii) All electromagnetic waves travel at the same speed. What is the value of this speed?

..... [1]

- (b) The astronaut has a mass of 96 kg. The gravitational field strength on the Moon is about one sixth of that on the Earth.

State the difference, if any, between

- (i) the mass of the astronaut on the Earth and on the Moon,

..... [1]

- (ii) the weight of the astronaut on the Earth and on the Moon.

..... [1]

- (c) The astronaut stands on the surface of the Moon and drops a ball. The graph in Fig. 3.2 shows the speed of the ball over a period of 1.6 seconds.

For
Examiner's
Use

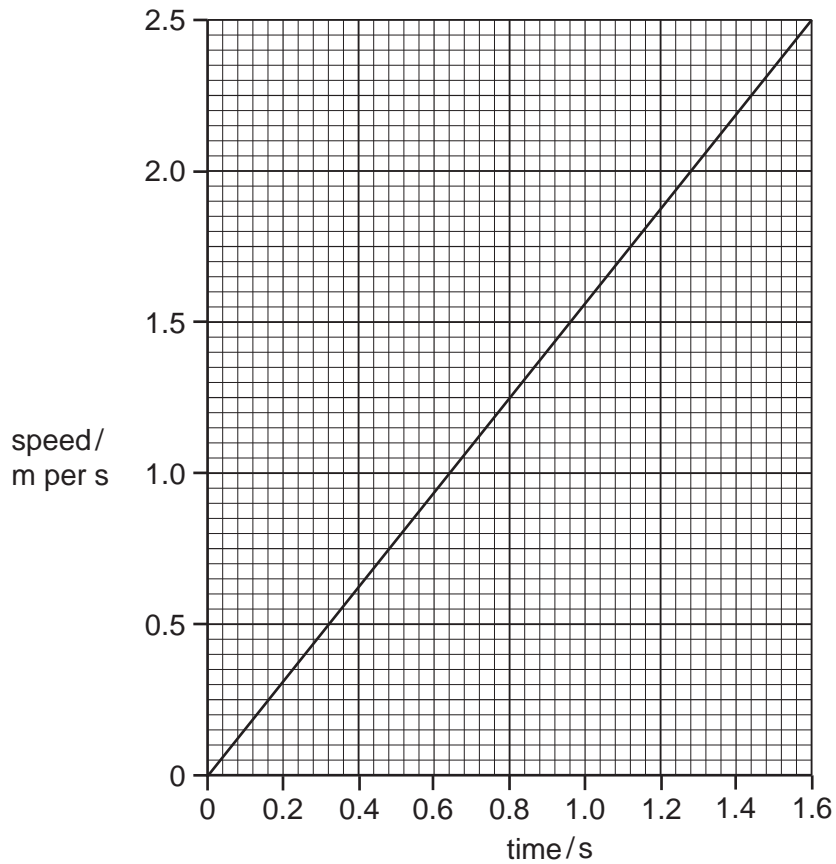

Fig. 3.2

- (i) On the same graph, sketch a line to show the speed of the same ball if it was dropped on Earth. [1]
- (ii) Explain your answer to (c)(i).

.....

..... [1]

(d) A rock on the Moon weighs 6 N. The astronaut lifts it up by 2 metres.

(i) Calculate the work done on the rock.

State the formula that you use and show your working.

formula

working

For
Examiner's
Use

..... [2]

(ii) If the rock was lifted in 2 seconds, calculate the power used.

State the formula that you use and show your working.

formula

working

..... [2]

4 Fig. 4.1 shows a section through a human heart, seen from the front.

For
Examiner's
Use

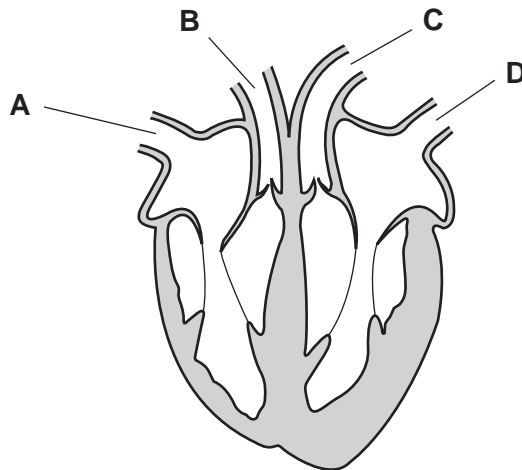

Fig. 4.1

(a) (i) Name the type of tissue found in the walls of the heart, as shown in the shaded parts in Fig. 4.1.

..... [1]

(ii) Describe how this tissue is supplied with oxygen.

.....

 [2]

(iii) Give the letters of the **two** labelled blood vessels that contain oxygenated blood.

..... and [1]

(b) Plants also have transport systems in which liquids flow through vessels. However, they do not have a pump like the heart.

(i) Explain what makes water flow up through the xylem vessels in a plant.

.....

 [2]

(ii) Describe how sugars, made in a plant's leaves, are transported to its roots.

.....

 [2]

5 (a) Some fuels are listed below.

animal dung

coal

wood

State **one** reason why coal is an example of a fossil fuel whereas the other two are not.

.....
 [1]

(b) Fig. 5.1 shows a simplified diagram of fractional distillation and catalytic cracking which are both carried out at an oil refinery. Compounds leaving the fractional distillation column at **M** move into the catalytic cracker.

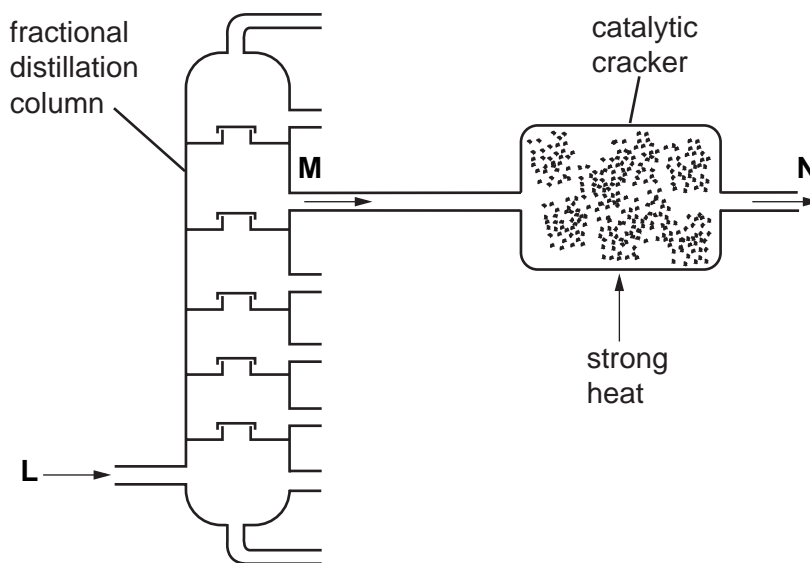

Fig. 5.1

(i) Name the raw material which enters at **L**. [1]

(ii) Describe briefly **two** ways, other than colour and odour, in which the mixture of compounds at **M** differs from the mixture of compounds at **L**.

.....

 [2]

(iii) Describe briefly **two** ways in which the mixture of compounds at **N** differs from the mixture of compounds at **M**.

1
 2 [2]

- (iv) Some of the compounds in the mixture at **N** can be used in addition polymerisation.

Explain why addition polymers can be made from molecules in the mixture at **N** but not from molecules in the mixture at **M**.

You may draw a diagram if it helps you to answer this question.

.....

 [2]

- (c) A student investigated the combustion products of the liquid fuel ethanol.

He observed that a gas and a colourless liquid were produced.

- (i) The student applied a chemical test to the colourless liquid and found that it was water.

Describe a suitable chemical test for water and its result.

.....

 [2]

- (ii) Complete the equation below for the combustion of ethanol.



6 Fig. 6.1 shows a cube.

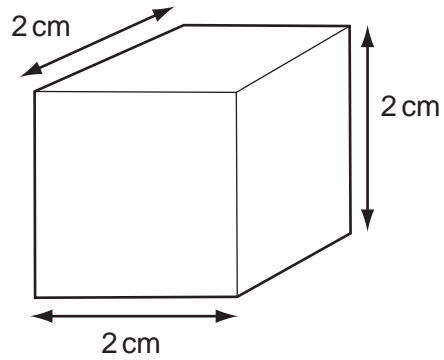

Fig. 6.1

(a) The mass of the cube is 21.6 g.

Calculate the density of the cube.

State the formula that you use and show your working.

formula

working

..... [3]

(b) The solid cube is made up of very small particles. Fig. 6.2 shows their arrangement.

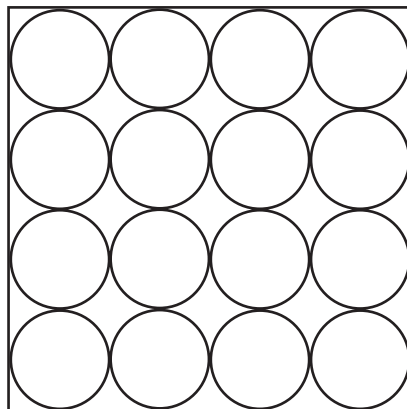
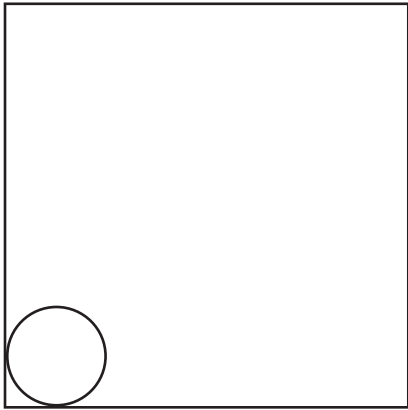
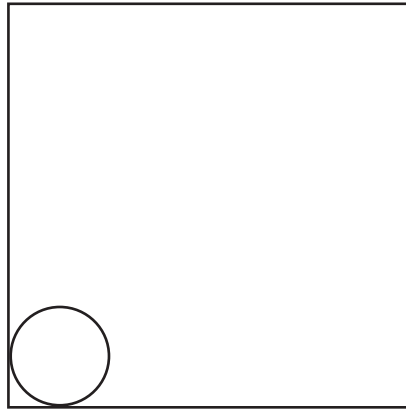

Fig. 6.2

(i) Complete the diagrams below to show the arrangement of particles in a liquid and in a gas.



liquid



gas

[2]

(ii) Explain your answer to (b)(i) in terms of forces between particles.

.....
.....
..... [2]

(c) Explain, in terms of particles, why a solid expands when heated.

.....
.....
..... [1]

(d) Describe **one** problem caused by a solid metal expanding when it gets hot.

.....
.....
..... [2]

7 (a) A student peeled a layer of cells from the inside of an onion bulb. He placed them in a drop of water on a microscope slide and covered them with a coverslip.

Fig. 7.1 shows what he saw when viewing the cells through a microscope.

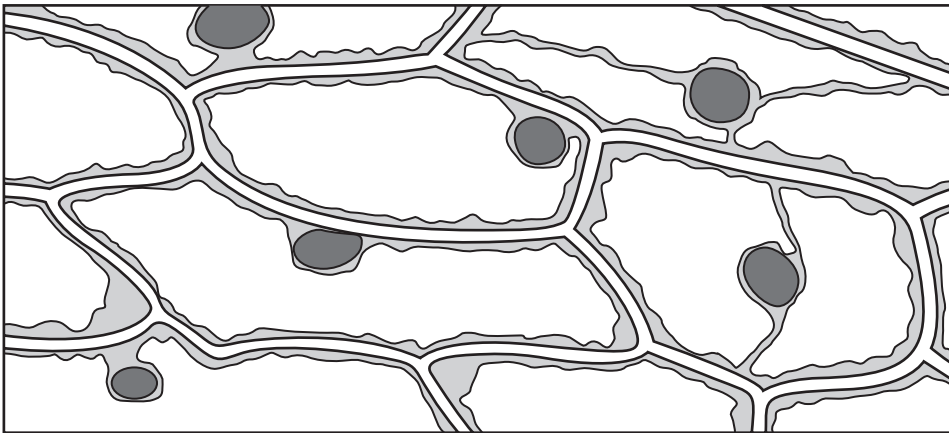

Fig. 7.1

(i) The cells in Fig. 7.1 are similar to each other.

Give the name for a group of similar cells.

.....

[1]

(ii) State **two** ways in which the cells in Fig. 7.1 differ from animal cells.

1

2 [2]

(b) The student replaced the water on the slide with a drop of concentrated sugar solution. He waited for five minutes and then looked at the cells through the microscope again.

Fig. 7.2 shows what he saw.

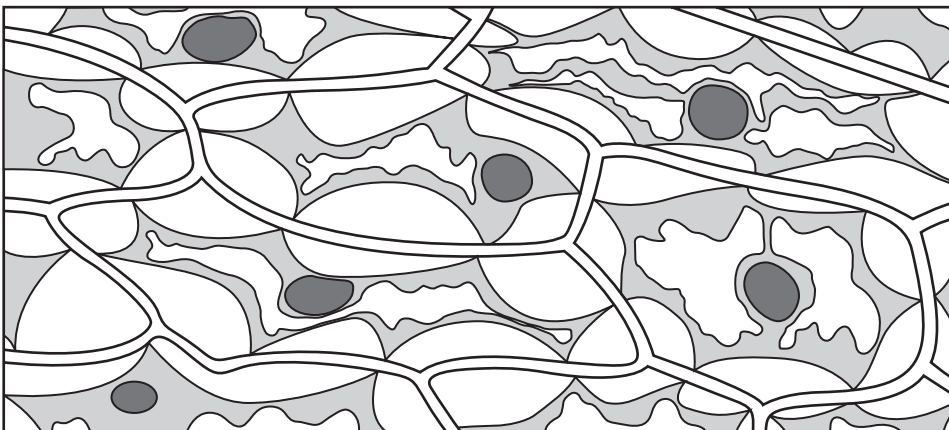

Fig. 7.2

(i) On Fig. 7.2, label a partially permeable membrane. [1]

(ii) Using your knowledge of osmosis, explain what has happened to the cells in Fig. 7.2.

.....
.....
.....
.....
..... [3]

(c) Onion cells often contain stores of starch. When a person eats an onion, the starch is digested.

Describe how starch is digested in the human alimentary canal.

.....
.....
.....
..... [3]

For
Examiner's
Use

- 8 (a) A student used the apparatus in Fig. 8.1 to investigate the rate of a reaction.

For
Examiner's
Use

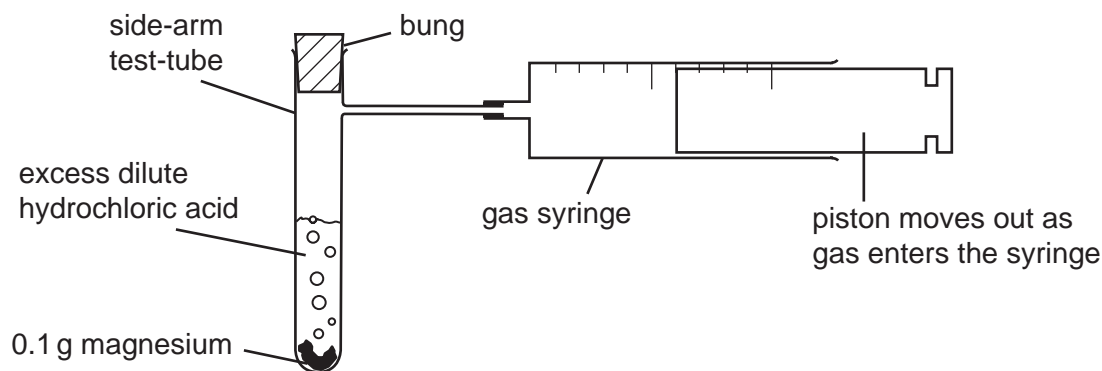

Fig. 8.1

The student dropped the magnesium into the acid contained in the side-arm test-tube and put in the bung. A stopwatch was used to time how long it took for 50 cm^3 of gas to collect in the syringe.

The student carried out four experiments **A**, **B**, **C** and **D**, and the results are shown in Table 8.1.

Table 8.1

experiment	time for 50 cm^3 of gas to collect in the gas syringe / seconds
A	36
B	18
C	144
D	72

- (i) Explain how the results show that experiment **B** had a higher rate of reaction than experiment **A**.

.....
 [1]

- (ii) The only variable (factor) which was different between the four experiments **A**, **B**, **C** and **D** was the concentration of the dilute hydrochloric acid.

Using the letters **A**, **B**, **C** and **D**, list the experiments in order of decreasing acid concentration.

..... (highest concentration)

.....

.....

..... (lowest concentration)

[1]

- (iii) Fig. 8.2 shows a piece of magnesium in a beaker of dilute hydrochloric acid. The hydrogen ions, present in all aqueous acids, are shown by the symbol • .

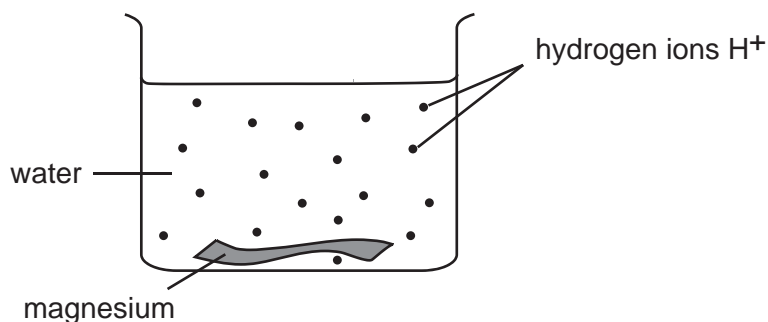

Fig. 8.2

Explain, in terms of ions, why the rate of reaction will change when the concentration of the acid is changed.

.....

.....

.....

.....

.....

..... [3]

- (b) Magnesium reacts with hydrochloric acid to form magnesium chloride and hydrogen gas.

The chemical formula for magnesium chloride is MgCl_2 . Use the Periodic Table on page 20 to calculate the relative formula mass of magnesium chloride.

Show your working.

..... [2]

For
Examiner's
Use

- 9 (a) Fig. 9.1 shows a teacher with a torch (flash light). He switches the torch on and points it at the mirror.

For
Examiner's
Use



Fig. 9.1

A ray of light from the torch reflects off the mirror.

Use a ruler to draw a ray of light

- (i) from the torch to the mirror,
- (ii) reflecting off the mirror. [2]

- (b) A torch contains two cells providing a total voltage of 3.0 V across the lamp. When the torch is lit, the current flowing through the lamp is 0.3 A.

- (i) Calculate the resistance of the lamp.

State the formula that you use and show your working.

formula

working

..... [2]

- (ii) To measure the current through the lamp and the voltage across the lamp, the student set up the circuit in Fig. 9.2.

*For
Examiner's
Use*

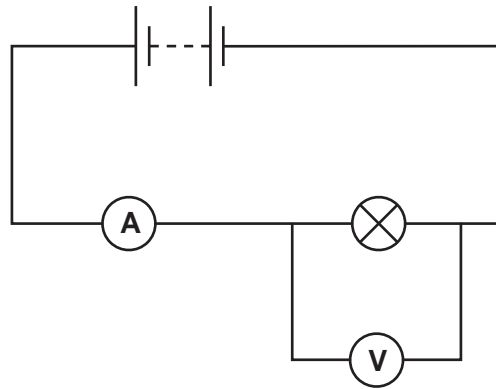

Fig. 9.2

The student sketched a graph of current against voltage for the lamp. This is shown in Fig. 9.3.

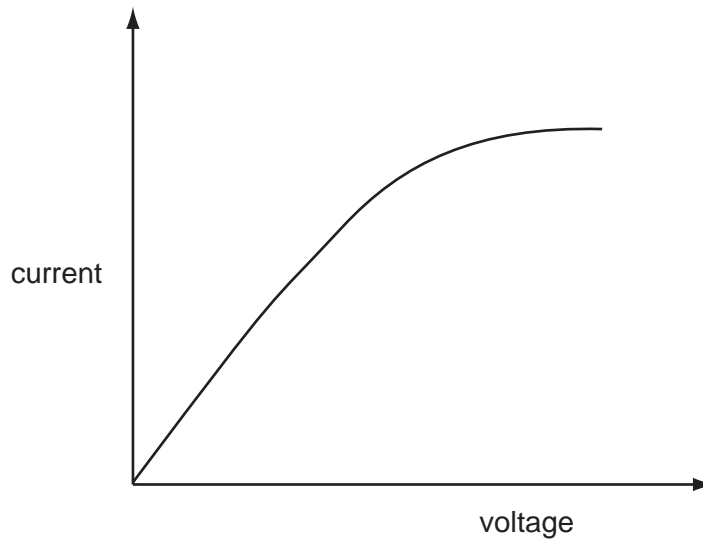

Fig. 9.3

Does the lamp obey Ohms Law?

Explain your answer.

.....
 [2]

DATA SHEET
The Periodic Table of the Elements

		Group																																		
I	II	III	IV	V	VI	VII	0																													
		1 H Hydrogen 1										4 He Helium 2																								
7 Li Lithium 3	9 Be Beryllium 4											20 Ne Neon 10																								
23 Na Sodium 11	24 Mg Magnesium 12	27 Al Aluminium 13	28 Si Silicon 14	31 P Phosphorus 15	32 S Sulfur 16	35.5 Cl Chlorine 17	40 Ar Argon 18						84 Kr Krypton 36																							
39 K Potassium 19	40 Ca Calcium 20	45 Sc Scandium 21	48 Ti Titanium 22	51 V Vanadium 23	52 Cr Chromium 24	55 Mn Manganese 25	56 Fe Iron 26	59 Co Cobalt 27	59 Ni Nickel 28	64 Cu Copper 29	65 Zn Zinc 30	70 Ga Gallium 31	73 Ge Germanium 32	75 As Arsenic 33	79 Se Selenium 34	80 Br Bromine 35	84 Kr Krypton 36																			
85 Rb Rubidium 37	88 Sr Strontium 38	89 Y Yttrium 39	91 Zr Zirconium 40	93 Nb Niobium 41	96 Mo Molybdenum 42	101 Ru Ruthenium 44	101 Ru Ruthenium 44	103 Rh Rhodium 45	106 Pd Palladium 46	108 Ag Silver 47	112 Cd Cadmium 48	115 In Indium 49	119 Sn Tin 50	122 Sb Antimony 51	128 Te Tellurium 52	127 I Iodine 53	131 Xe Xenon 54	133 Cs Caesium 55																		
137 Ba Barium 56	137 Ba Barium 56	139 La Lanthanum 57	178 Hf Hafnium 72	181 Ta Tantalum 73	184 W Tungsten 74	190 Os Osmium 76	190 Os Osmium 76	192 Ir Iridium 77	195 Pt Platinum 78	197 Au Gold 79	201 Hg Mercury 80	204 Tl Thallium 81	207 Pb Lead 82	209 Bi Bismuth 83	209 Po Polonium 84	209 At Astatine 85	209 Rn Radon 86	226 Ra Radium 88																		
87 Fr Francium	88 Ra Radium	89 Ac Actinium																																		
*58-71 Lanthanoid series																		140 Ce Cerium 58	141 Pr Praseodymium 59	144 Nd Neodymium 60	150 Sm Samarium 62	152 Eu Europium 63	157 Gd Gadolinium 64	159 Tb Terbium 65	162 Dy Dysprosium 66	165 Ho Holmium 67	167 Er Erbium 68	169 Tm Thulium 69	173 Yb Ytterbium 70	175 Lu Lutetium 71						101 Md Mendelevium
†90-103 Actinoid series																		90 Th Thorium	91 Pa Protactinium	92 U Uranium	93 Np Neptunium	94 Pu Plutonium	95 Am Americium	96 Cm Curium	97 Bk Berkelium	98 Cf Californium	99 Es Einsteinium	100 Fm Fermium	101 Md Mendelevium	102 No Nobelium	103 Lr Lawrencium					

Key

a	X	a = relative atomic mass
	X	X = atomic symbol
b		b = proton (atomic) number

The volume of one mole of any gas is 24 dm³ at room temperature and pressure (r.t.p.).

Permission to reproduce items where third-party owned material protected by copyright is included has been sought and cleared where possible. Every reasonable effort has been made by the publisher (UCLES) to trace copyright holders, but if any items requiring clearance have unwittingly been included, the publisher will be pleased to make amends at the earliest possible opportunity.

University of Cambridge International Examinations is part of the Cambridge Assessment Group. Cambridge Assessment is the brand name of University of Cambridge Local Examinations Syndicate (UCLES), which is itself a department of the University of Cambridge.