



UNIVERSITY OF CAMBRIDGE INTERNATIONAL EXAMINATIONS
International General Certificate of Secondary Education

CANDIDATE
NAME

CENTRE
NUMBER

--	--	--	--	--

CANDIDATE
NUMBER

--	--	--	--	--

* 8 6 2 1 4 6 9 5 2 2 *

**COMBINED SCIENCE
CO-ORDINATED SCIENCES**

**0653/06
0654/06**

Paper 6 Alternative to Practical

May/June 2009

1 hour

Candidates answer on the Question paper

No Additional Materials are required.

READ THESE INSTRUCTIONS FIRST

Write your Centre number, candidate number and name on all the work you hand in.

Write in dark blue or black pen.

You may use a soft pencil for any diagrams, graphs, tables or rough working.

Do not use staples, paper clips, highlighters, glue or correction fluid.

DO NOT WRITE IN ANY BARCODES.

Answer **all** questions.

At the end of the examination, fasten all your work securely together.

The number of marks is given in brackets [] at the end of each question or part question.

For Examiner's Use	
1	
2	
3	
4	
5	
6	
Total	

This document consists of **18** printed pages and **2** blank pages.



- 1 A student has drawn two flowers as part of an investigation to compare an insect-pollinated with a wind-pollinated flower.

For
Examiner's
Use

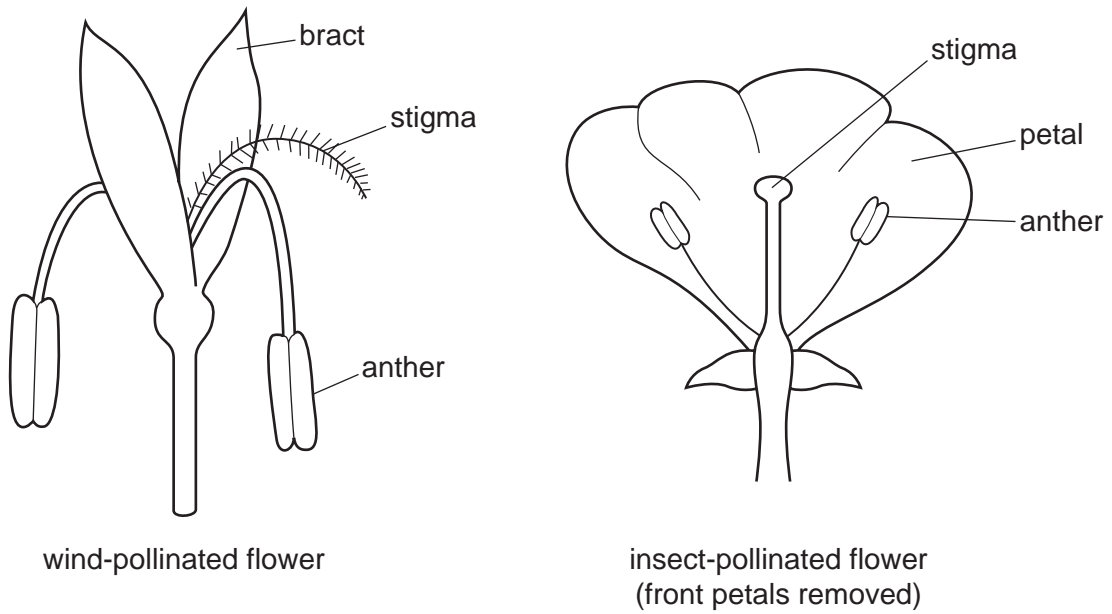

Fig. 1.1

Construct a table to compare the features, visible in the diagrams, of the two flowers. Your table should include **three** features of the flowers.

[6]

- 2 The teacher gives a student a piece of zinc and some dilute hydrochloric acid. The student uses the apparatus in Fig. 2.1 to investigate the speed of reaction of the zinc and hydrochloric acid.

For
Examiner's
Use

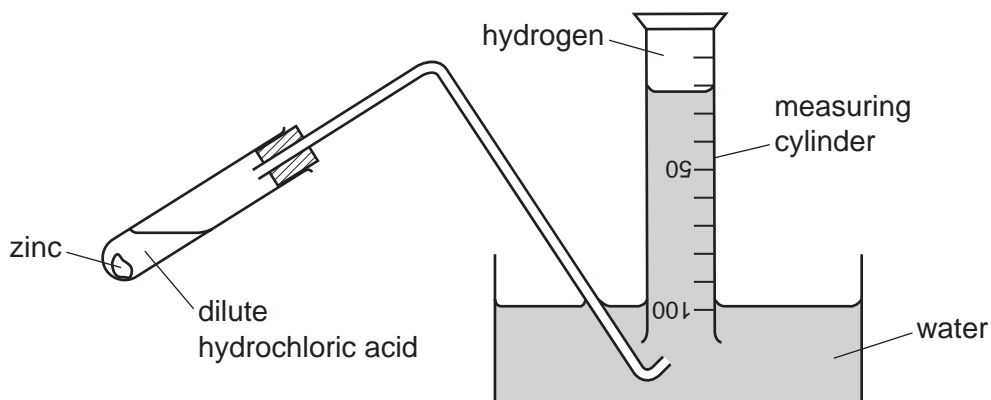

Fig. 2.1

- The student places 4 cm^3 of the acid in a test-tube.
- He starts his clock.
- Every minute, he records in Fig. 2.2 the total volume of gas collected in the measuring cylinder.

time / minutes	0	1	2	3	4	5
total volume of gas / cm^3	0	50				97

Fig. 2.2

- (a) Fig. 2.3 shows the scale of the measuring cylinder at the second, third and fourth minutes. Record the readings in Fig. 2.2. [3]

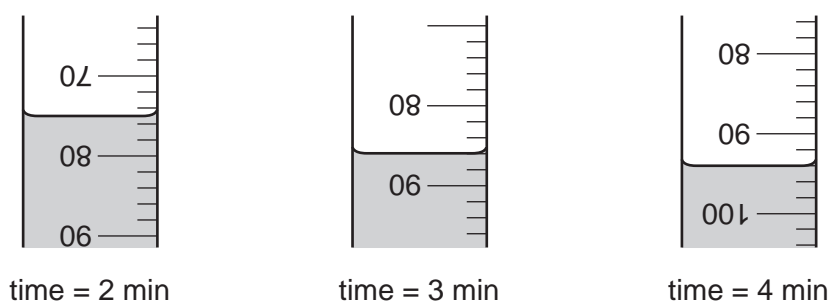

Fig. 2.3

- (b) The student decides that the gas is produced at a slower rate as time goes on.
- (i) What does the student observe in the test-tube that confirms this?

.....

..... [1]

- (ii) Use the data in Fig. 2.3 to show that the rate of production of gas decreases as time goes on.

For
Examiner's
Use

[2]

After the reaction has stopped, the student pours the liquid out of the test-tube. He compares the sizes of the piece of zinc before and after the reaction. This is shown in Fig. 2.4.

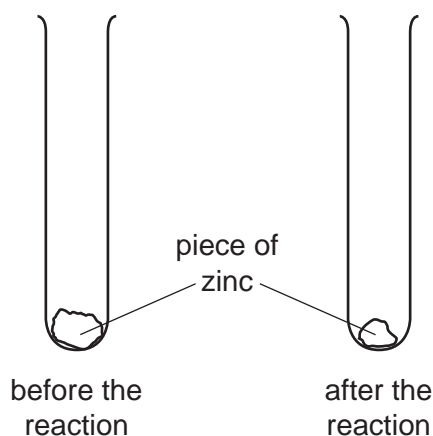

Fig. 2.4

- (c) The student suggests five reasons why the rate of production of gas slowed down. Which **one** of his reasons is correct? Tick **one** box to show your answer.

- | | | |
|----------|--------------------------|--|
| A | <input type="checkbox"/> | the surface area of the zinc decreased |
| B | <input type="checkbox"/> | the mass of the zinc decreased |
| C | <input type="checkbox"/> | the temperature of the mixture decreased |
| D | <input type="checkbox"/> | the concentration of the acid decreased |
| E | <input type="checkbox"/> | the volume of the acid decreased |

[1]

(d) (i) Describe how the student can show that the gas in the measuring cylinder is hydrogen.

.....
.....
..... [2]

(ii) Write a word equation for the reaction of the hydrogen gas in the test you have described in **(d)(i)**.

..... [1]

*For
Examiner's
Use*

Please turn over for Question 3.

- 3 A student does an experiment to investigate the acceleration of a trolley. The trolley has a mass of 1 kg. It runs along a horizontal track 1 metre long. The trolley is pulled by a string that runs over a pulley, with a 1 kg mass fixed to it. When the hanging mass is allowed to fall, it pulls the trolley so that it accelerates along the track. Fig. 3.1 shows this apparatus.

For
Examiner's
Use

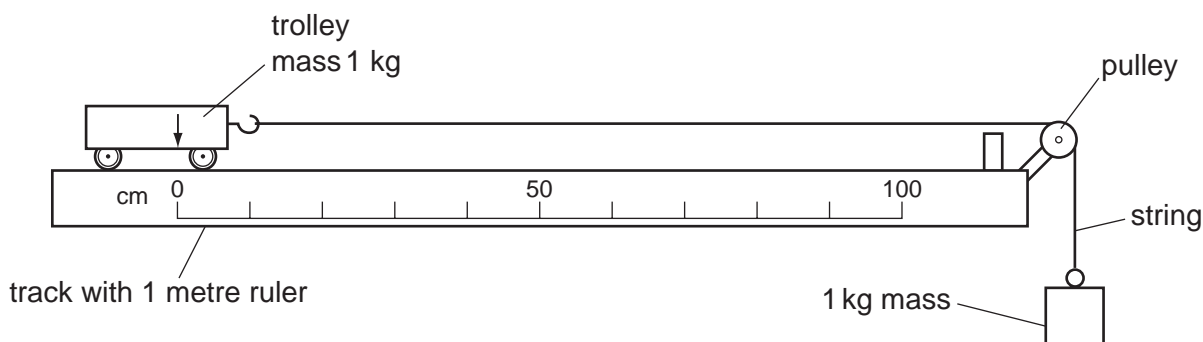

Fig. 3.1

- the 1 kg mass is released at time 0 seconds
- a camera photographs the trolley at 0.1 s intervals
- the pictures of the trolley are used to find the distances it travelled
- the distances, in centimetres, are recorded in Fig. 3.2

time t/s	0	0.1	0.2	0.3	0.4	0.5
distance / cm	0				76	96

Fig. 3.2

- (a) The images of the trolley and the metre rule at $t = 0.1, 0.2$ and 0.3 s are shown in Fig. 3.3. Read the scales and record the distances in centimetres in Fig. 3.2. [3]

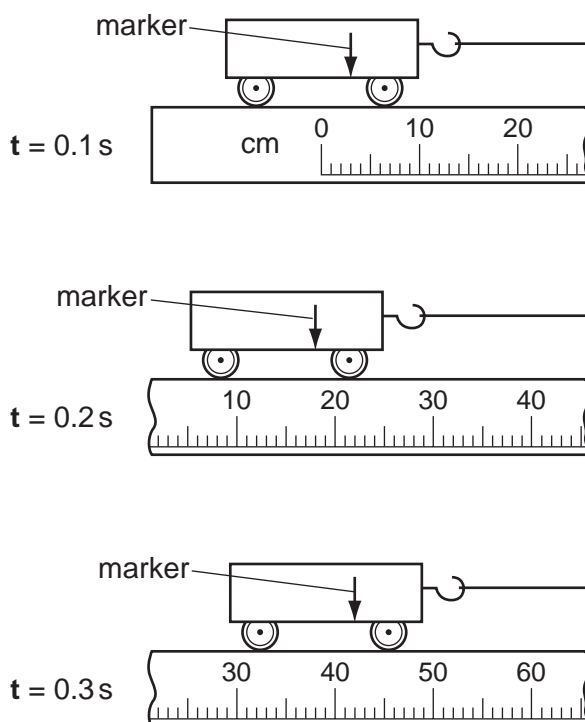

Fig. 3.3

- (b) Plot a graph of distance moved in centimetres (vertical axis) against time t in seconds (horizontal axis) on the grid provided. Draw a smooth curve through the points. [3]

For
Examiner's
Use

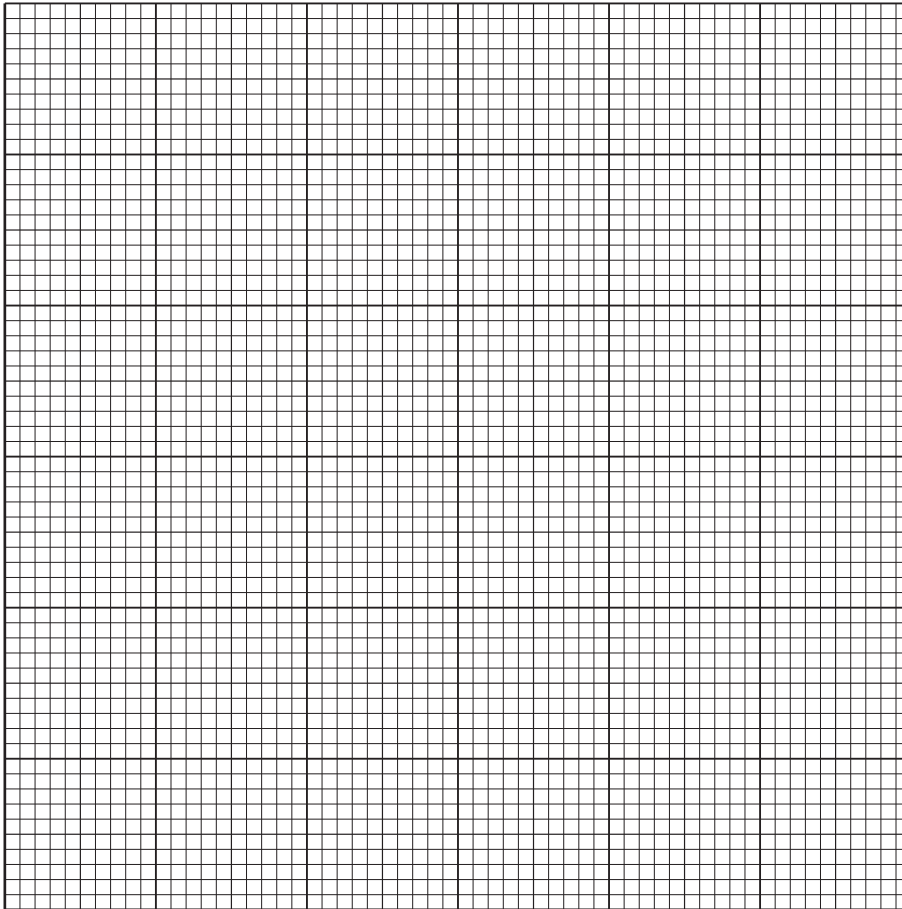

Fig. 3.4

- (c) Show that the trolley accelerates as it moves along the track. You may show this on the graph or write an explanation below.

.....

.....

.....

..... [2]

(d) The student wants to change the mass of the trolley and the 1 kg mass. Suggest how the results will change if

For
Examiner's
Use

(i) the trolley has a mass of 2 kg instead of 1 kg,

.....
..... [1]

(ii) the 1 kg hanging mass is replaced by a 2 kg mass.

.....
..... [1]

- 4 Hydrogen peroxide is produced in some living cells during chemical reactions. It is poisonous if it is not removed quickly. The enzyme catalase is also found in living cells. It speeds up the breakdown of hydrogen peroxide to produce oxygen gas.

For
Examiner's
Use

A student carried out an experiment to compare the activity of catalase in two different tissues by measuring the rate of oxygen production.

- He put some hydrogen peroxide solution into a test-tube.
- He added some detergent to produce a foam of trapped oxygen. See Fig. 4.1.
- He then added tissue **A**, potato, to the hydrogen peroxide solution and started timing.
- He measured the height of foam, **h**, every minute for 5 minutes and recorded the readings in Fig. 4.2.
- The student then repeated the experiment with tissue **B**, animal's liver.

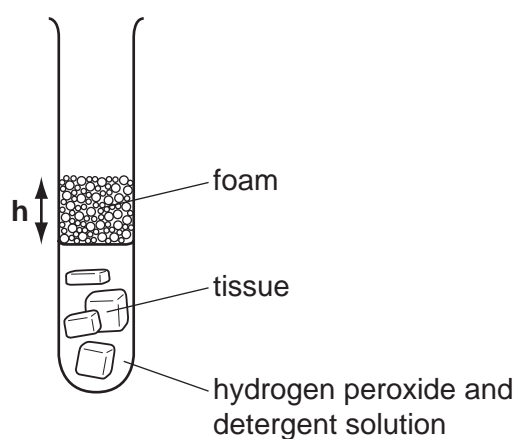

Fig. 4.1

time / mins	height of foam h / mm	
	tissue A	tissue B
0	0	0
1	6	
2	10	82
3	15	90
4	18	95
5		98

Fig. 4.2

- (a) Fig. 4.3 shows the rulers used to measure the height of foam, h . Read these values and complete Fig. 4.2. [2]

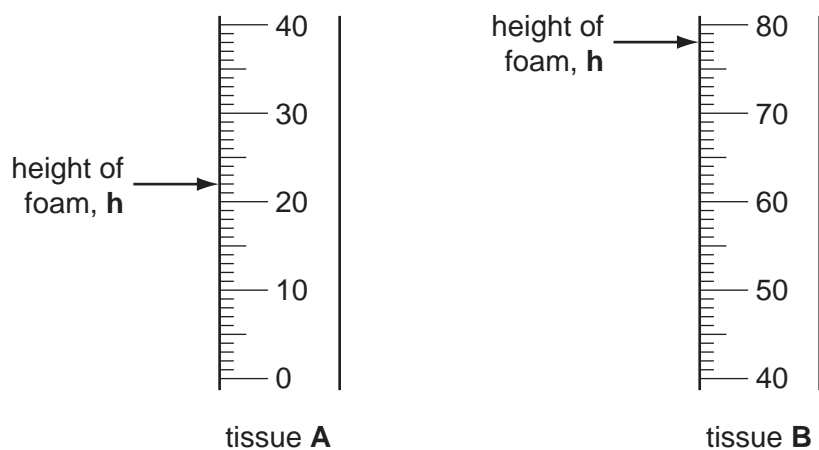

Fig. 4.3

- (b) Using the results for tissue **A** plot height of foam, h (vertical axis), against time on Fig. 4.4. Draw a smooth curve through the points and label the line **A**.

On the same grid plot the results for tissue **B** and label the curve **B**.

[5]

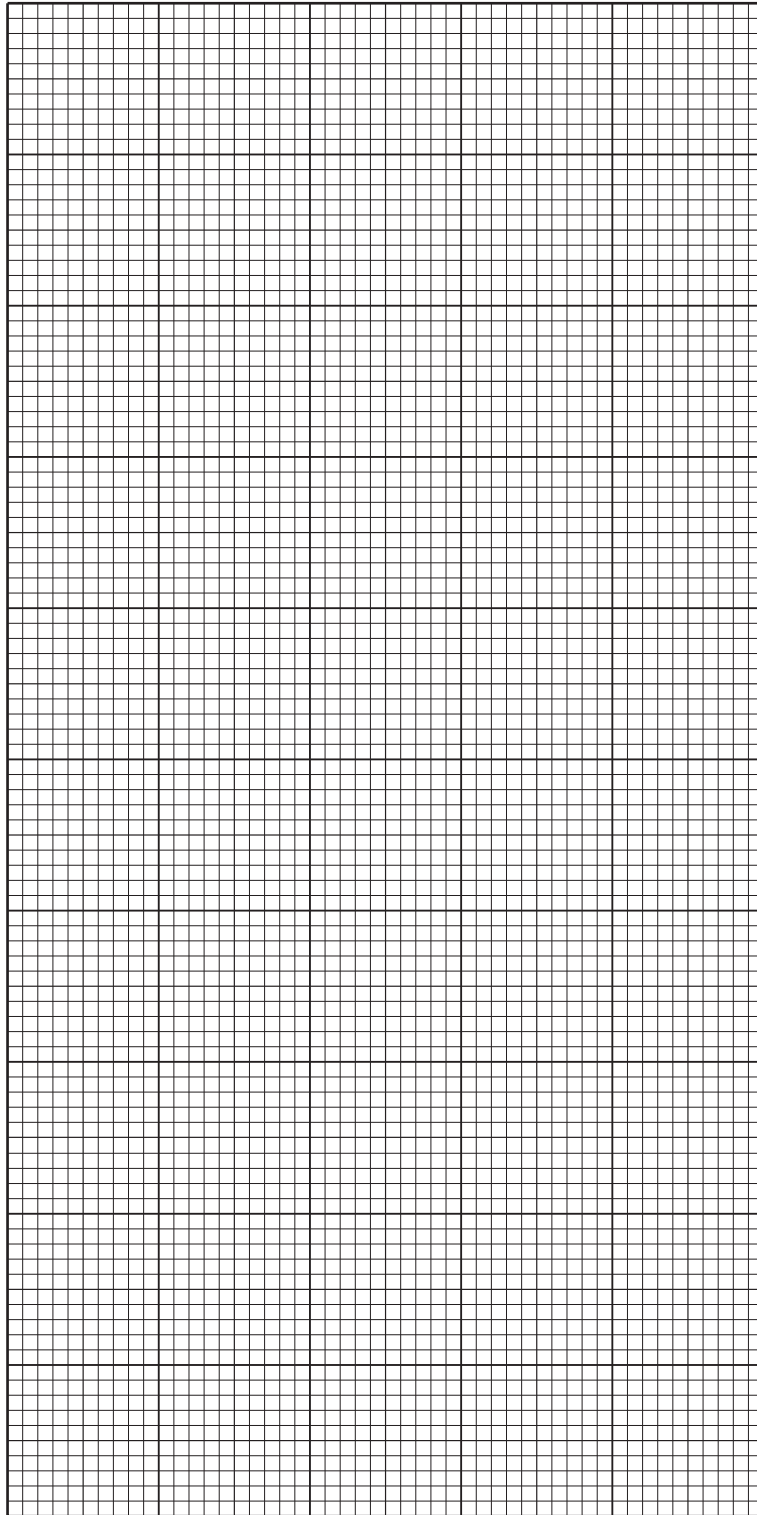

Fig. 4.4

(c) In which tissue, **A** or **B** was the catalase more active?

.....

How did you decide ?

.....

..... [2]

(d) Look at the results for tissue **B**.

By how much did the foam increase between the following times

between 0 and 2 minutes, mm

between 3 and 5 minutes? mm

Suggest a reason for the difference.

.....

..... [3]

(e) How can the experiment be adapted to measure in cm^3 the volume of oxygen gas produced?

You may draw a diagram to illustrate your answer

[2]

5 A student is investigating the reaction between copper(II) sulfate and the reducing sugar glucose.

(a) He adds Benedict's solution, which contains copper(II) sulfate, to glucose solution and warms the mixture. It turns green, then yellow-orange and finally red. A red precipitate is formed in a colourless solution.

(i) What colour is the Benedict's solution at first?

..... [1]

(ii) Draw a diagram to show how the red precipitate can be separated from the solution.

[2]

The teacher says that the red precipitate is an oxide of copper, made by the reduction of the copper in copper(II) sulfate, CuSO_4 .

(iii) Suggest the formula of the red oxide of copper. Choose from the following.



..... [1]

(b) The student places some of the red oxide of copper in a test-tube, adds dilute sulfuric acid and warms the mixture. Then he allows the mixture to stand. He sees a blue solution and a brown solid.

The student thinks that the blue solution is copper(II) sulfate and that the brown solid is copper metal.

Suggest a test that will show that the brown solid is a metal.

.....
..... [1]

- (c) The student places some copper(II) sulfate solution in a test tube and adds an equal volume of aqueous potassium iodide. The mixture turns deep brown.

The student suggests that the brown colour is caused by iodine. How can he confirm the presence of iodine in the solution?

test

result [2]

- (d) The student adds zinc powder to copper(II) sulfate solution. There is an exothermic reaction and a change of colour.

State three observations that the student could make.

1.

2.

3. [3]

- 6 A student must find the internal diameter of a large test-tube, shown in Fig. 6.1. He is told to carry out the procedure shown below.

For
Examiner's
Use

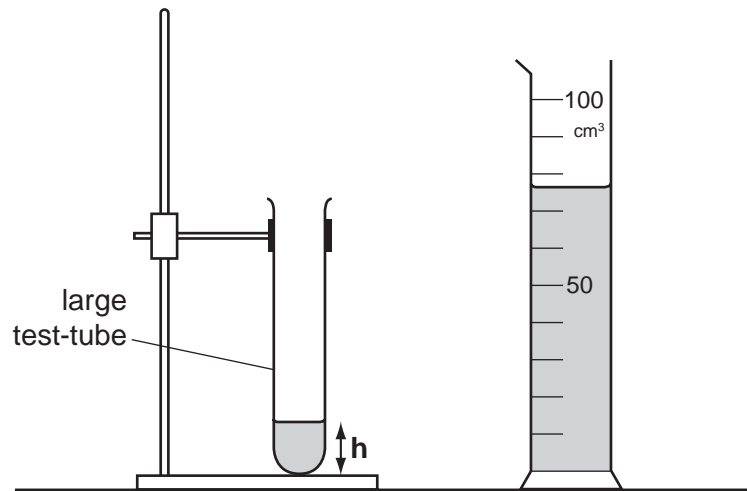

Fig. 6.1

Procedure

- Fill a measuring cylinder with water to the 100 cm^3 mark.
- Pour water from the measuring cylinder into the test-tube until it is about one-fifth full.
- Find the vertical height, h , of the water in the test-tube and record it.
- Record V , the volume of water remaining in the measuring cylinder.
- Add about 10 cm^3 of water to the test-tube. Record the new height h and the volume V .
- Repeat until there are 5 sets of readings in the table.

(a) Fig. 6.2 shows the heights of water in the test-tube and the corresponding volumes of water remaining in the measuring cylinder, for the missing readings of h and V , in Fig. 6.3.

For
Examiner's
Use

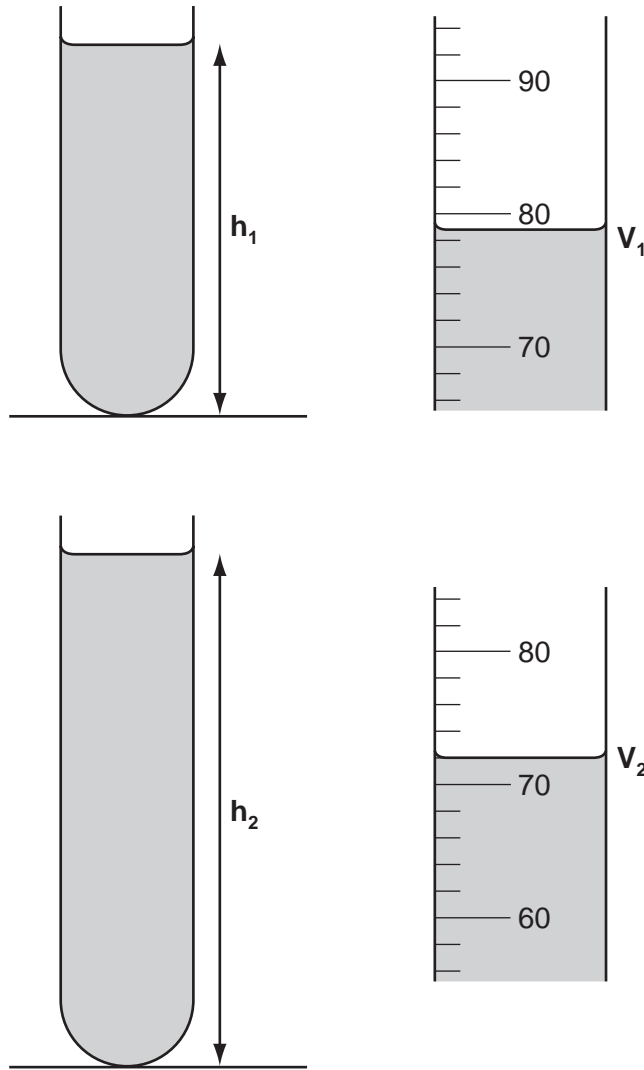

Fig. 6.2

- (i) Use a ruler to measure h_1 and h_2 to the nearest millimetre and record the values in Fig. 6.3. [2]
- (ii) Read the values of V_1 and V_2 to the nearest cm^3 and record them in Fig. 6.3. [2]
- (iii) Complete the third column of Fig. 6.3. [1]

height h / mm	volume V / cm^3	$(100 - V)$ / cm^3
25	89	9
$h_1 =$	$V_1 =$	$(100 - V_1) =$
$h_2 =$	$V_2 =$	$(100 - V_2) =$
93	60	40
113	51	49

Fig. 6.3

(b) On Fig. 6.4, plot a graph of $(100 - V)$ against h .
Draw the best straight line through the points.

[2]

For
Examiner's
Use

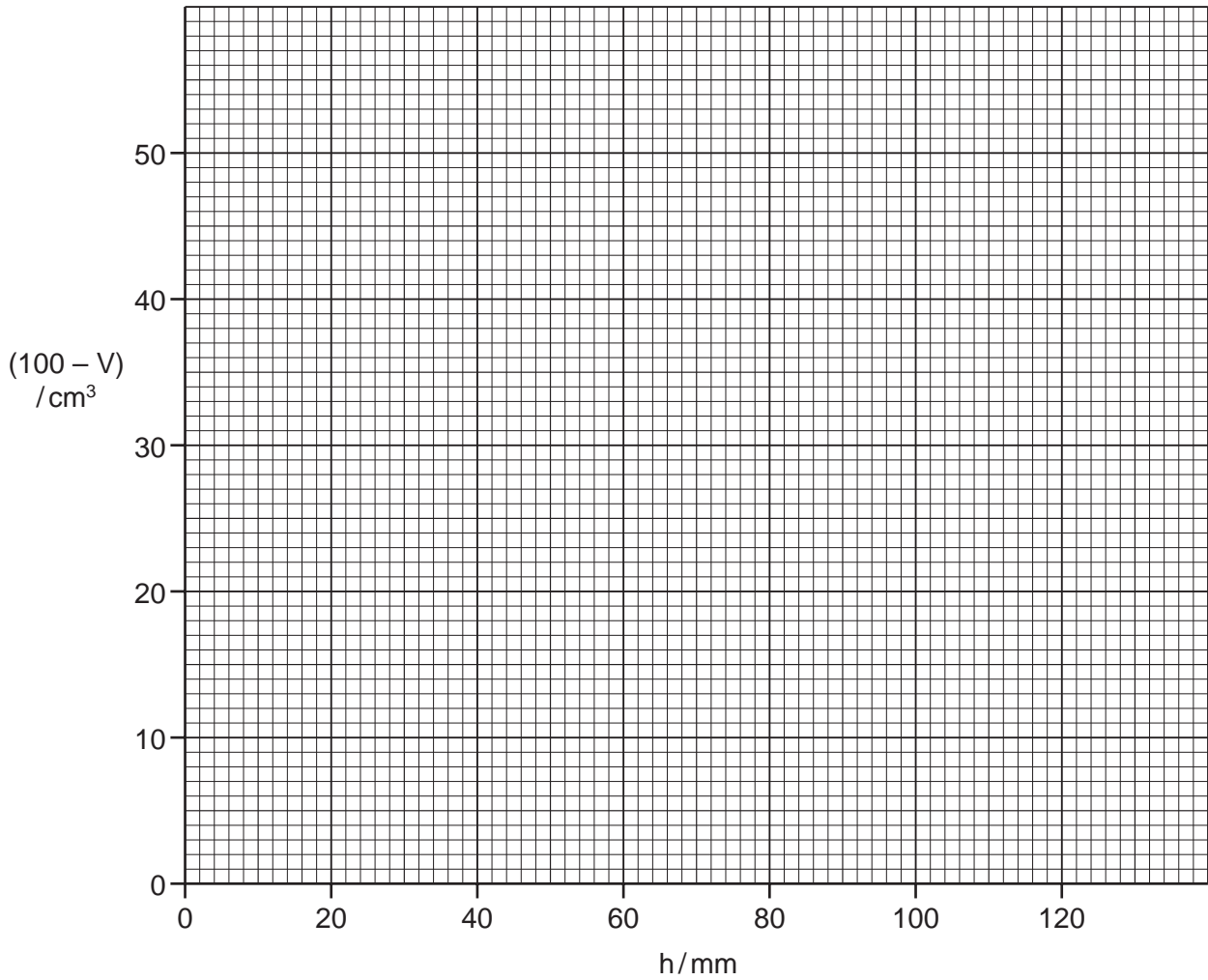

Fig. 6.4

(c) (i) Use your graph to find the volume, V_w , of water between $h = 30$ and $h = 100$ mm.

Show on your graph how you did this.

$V_w = \dots\dots\dots \text{cm}^3$ [2]

(ii) Calculate **d**, the internal diameter of the tube, using the equation

$$d = \frac{\sqrt{Vw}}{0.24}$$

For
Examiner's
Use

d = mm [1]

Permission to reproduce items where third-party owned material protected by copyright is included has been sought and cleared where possible. Every reasonable effort has been made by the publisher (UCLES) to trace copyright holders, but if any items requiring clearance have unwittingly been included, the publisher will be pleased to make amends at the earliest possible opportunity.

University of Cambridge International Examinations is part of the Cambridge Assessment Group. Cambridge Assessment is the brand name of University of Cambridge Local Examinations Syndicate (UCLES), which is itself a department of the University of Cambridge.