

| | | |
|---------------|------------------|------|
| Centre Number | Candidate Number | Name |
|---------------|------------------|------|

CAMBRIDGE INTERNATIONAL EXAMINATIONS
International General Certificate of Secondary Education

COMBINED SCIENCE

0653/01

Paper 1 Multiple Choice

May/June 2003

45 minutes

Additional Materials: Multiple Choice Answer Sheet
Soft clean eraser
Soft pencil (type B or HB is recommended)

READ THESE INSTRUCTIONS FIRST

Write in soft pencil.

Do not use staples, paper clips, highlighters, glue or correction fluid.

Write your name, Centre number and candidate number on the answer sheet in the spaces provided unless this has been done for you.

There are **forty** questions on this paper. Answer **all** questions. For each question there are four possible answers **A, B, C, and D**.

Choose the **one** you consider correct and record your choice in **soft pencil** on the separate answer sheet.

Read the instructions on the Answer Sheet very carefully.

Each correct answer will score one mark. A mark will not be deducted for a wrong answer.

Any rough working should be done in this booklet.

A copy of the Periodic Table is printed on page 20.

This document consists of **19** printed pages and **1** blank page.

1 Which pair of features is found in plant cells but **not** in animal cells?

| | | |
|----------|---------------|---------------|
| A | cell membrane | cell sap |
| B | cell sap | cell wall |
| C | cell wall | nucleus |
| D | nucleus | cell membrane |

2 The diagram shows a small part of a plant cell greatly magnified.

Which part controls what enters and leaves the cell?

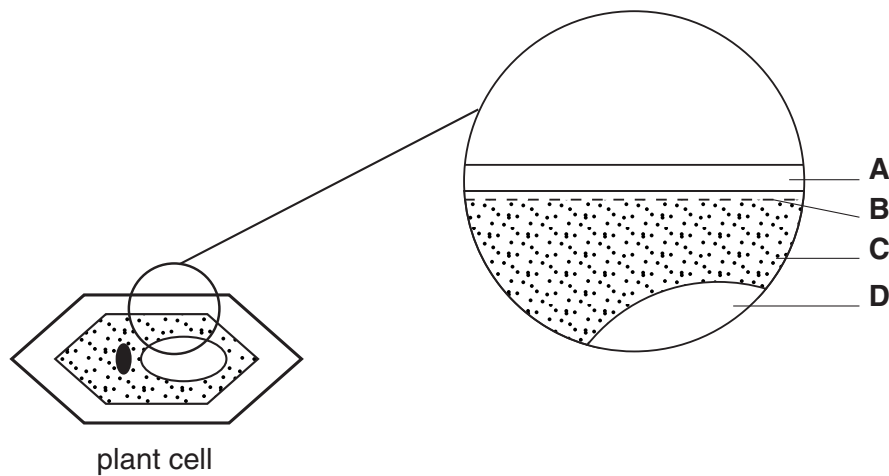

3 When an enzyme molecule has catalysed a chemical reaction in a cell, what happens to it?

- A** It acts as a catalyst again.
- B** It is denatured.
- C** It is digested.
- D** It is used up by the reaction.

4 There are four stages in testing a leaf for starch.

- 1 soften in hot water
- 2 stain with iodine
- 3 boil in alcohol
- 4 boil in water

What is the correct order for these stages?

| | | | | |
|----------|---|---|---|---|
| A | 1 | 2 | 3 | 4 |
| B | 1 | 4 | 3 | 2 |
| C | 3 | 1 | 2 | 4 |
| D | 4 | 3 | 1 | 2 |

5 The diagram shows some cells in a leaf of a green plant.

In which layer of cells does most photosynthesis occur?

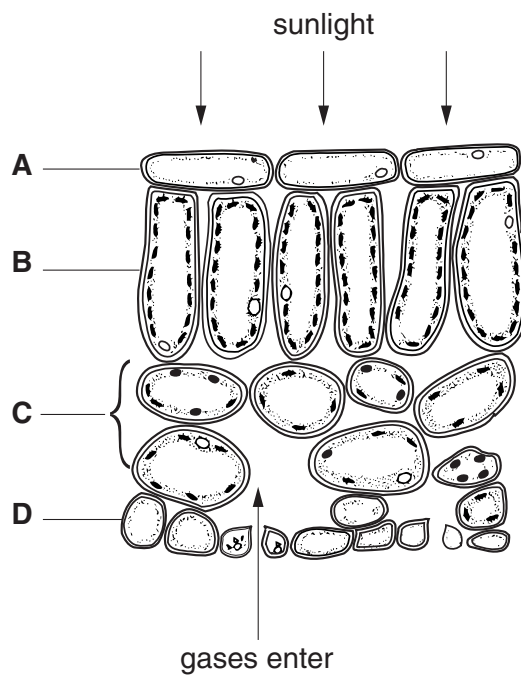

6 The diagram shows a section through a human tooth.

Which part is made of the hardest material?

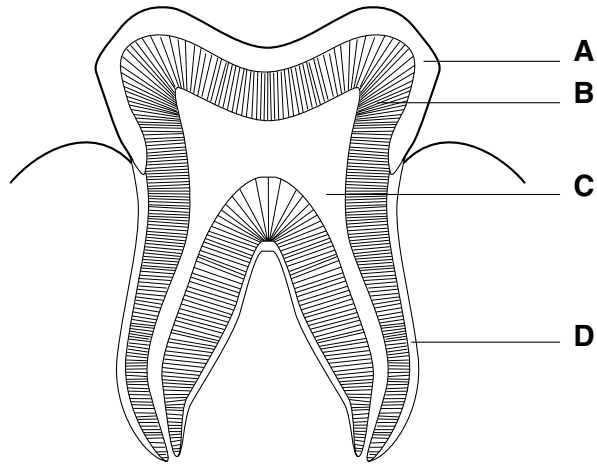

7 The pie-charts show the compositions of four different foods.

Which food contains the most energy?

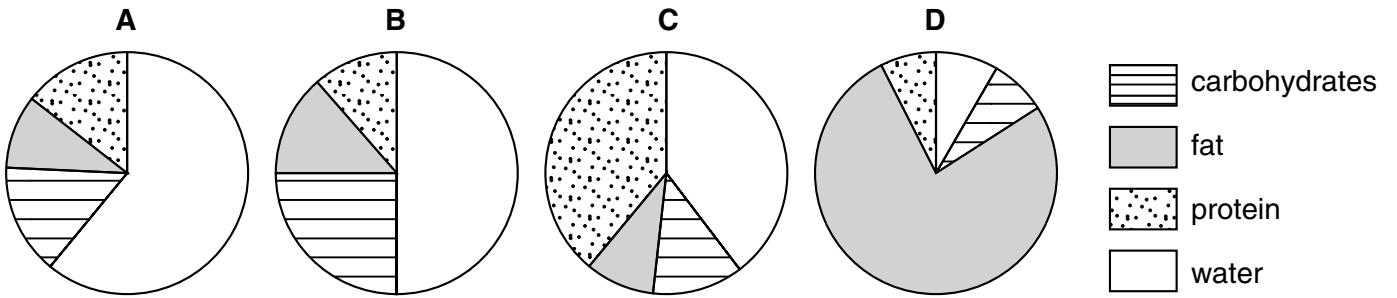

- 8 The diagram shows apparatus that can be used to demonstrate that the air breathed out by a person contains more carbon dioxide than the air breathed in.

The person breathes in and out at **X**.

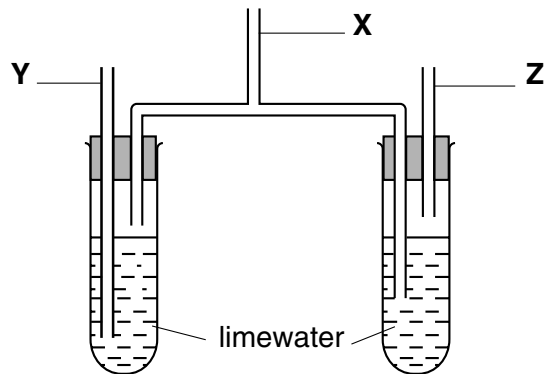

Where does air enter and leave the apparatus?

| | air enters at | air leaves at |
|----------|---------------|---------------|
| A | Y | Y |
| B | Y | Z |
| C | Z | Y |
| D | Z | Z |

- 9 Which cells destroy harmful microorganisms in the blood?

- A** goblet cells
- B** platelets
- C** red blood cells
- D** white blood cells

10 The diagram shows part of the human circulatory system.

Which structure carries oxygenated blood?

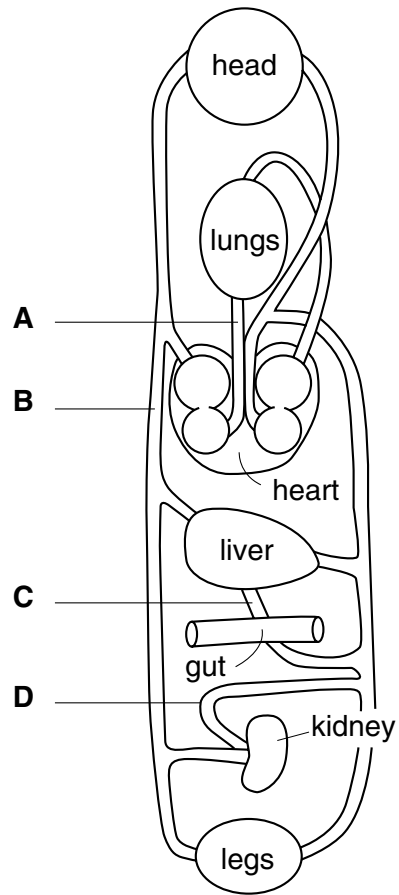

- 11 The drawing shows a plant in a container of water. There is a layer of oil on top of the water that stops the water evaporating. The apparatus weighs 300 g.

After two hours it weighs 296 g.

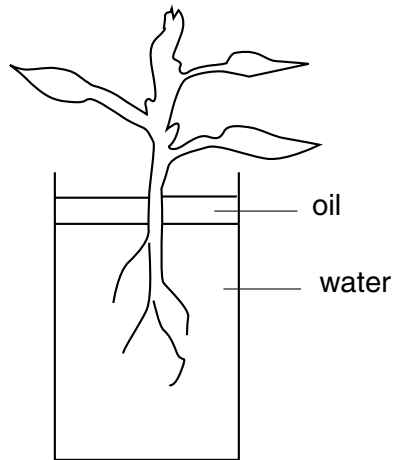

What is the rate of transpiration?

- A 150 g water / hour
 - B 148 g water / hour
 - C 4 g water / hour
 - D 2 g water / hour
- 12 Which organ releases insulin when the blood sugar level is too high?
- A kidney
 - B liver
 - C pancreas
 - D stomach

13 The diagram shows a section through a flower.

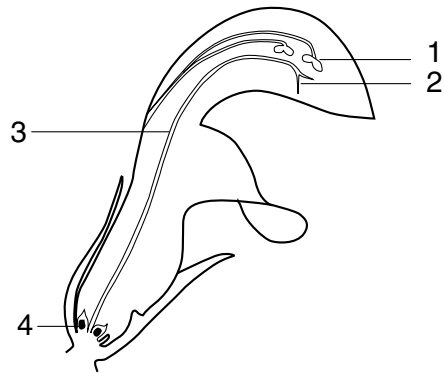

Where do the following occur?

| | pollination | fertilisation |
|----------|-------------|---------------|
| A | 1 | 2 |
| B | 2 | 4 |
| C | 3 | 1 |
| D | 4 | 3 |

14 Which process takes place when a sperm joins with an ovum?

- A** fertilisation
- B** intercourse
- C** menstruation
- D** sterilisation

15 Which diagrams show the bonding in the molecules of nitrogen and ethene?

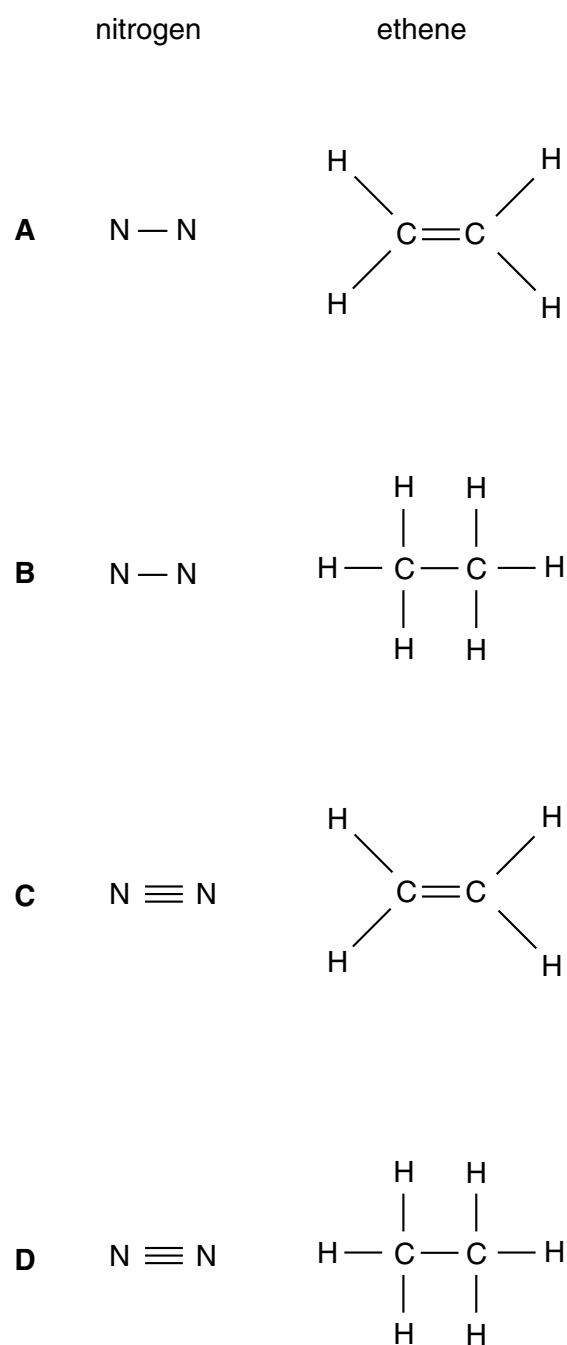

16 The reaction of zinc and sulphur to form zinc sulphide is exothermic.

Which information in the table is correct?

| | elements in a mixture of zinc and sulphur | elements in zinc sulphide | energy change during the reaction |
|----------|--|------------------------------|--------------------------------------|
| A | easy to separate | difficult to separate | heat given out |
| B | easy to separate | easy to separate | heat taken in |
| C | difficult to separate | difficult to separate | heat taken in |
| D | difficult to separate | easy to separate | heat given out |

17 Which substance is an ionic compound?

| | melting point | electrical conductivity when melted |
|----------|---------------|-------------------------------------|
| A | high | high |
| B | high | low |
| C | low | high |
| D | low | low |

18 Bromine is in the same group of the Periodic Table as chlorine.

What are the colour and formula of hydrobromic acid likely to be?

| | colour | formula |
|----------|------------|---------|
| A | brown | HOBBr |
| B | brown | HBr |
| C | colourless | HOBBr |
| D | colourless | HBr |

19 Which equation shows an **insoluble** base reacting with an acid?

- A** barium chloride + sulphuric acid \rightarrow barium sulphate + hydrochloric acid
- B** magnesium oxide + hydrochloric acid \rightarrow magnesium chloride + water
- C** sodium carbonate + hydrochloric acid \rightarrow sodium chloride + water + carbon dioxide
- D** zinc + sulphuric acid \rightarrow zinc sulphate + hydrogen

20 Flame tests are carried out on calcium chloride and copper(II) chloride.

What are the colours of the flames?

| | calcium chloride | copper(II) chloride |
|----------|------------------|---------------------|
| A | red | blue-green |
| B | blue-green | lilac |
| C | lilac | yellow |
| D | yellow | red |

- 21 In an experiment, 100 cm^3 of dry air are passed over heated copper turnings until there is no further change in volume (at r.t.p.).

What volume of gas remains?

- A 89 cm^3
 B 79 cm^3
 C 21 cm^3
 D 11 cm^3
- 22 A mixture of copper, magnesium and zinc is added to an excess of dilute sulphuric acid. The resulting mixture is then filtered.

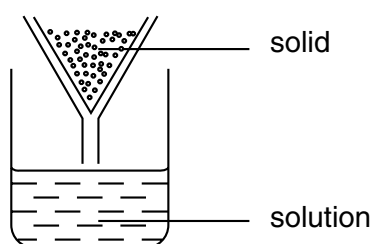

What is the solid left behind?

- A copper and magnesium
 B copper only
 C magnesium and zinc
 D zinc only
- 23 Which statement best describes how and why drinking water is sterilised?

| | how | why |
|---|----------------|--------------------------|
| A | boiled | bacteria cannot multiply |
| B | boiled | kills bacteria |
| C | chlorine added | bacteria cannot multiply |
| D | chlorine added | kills bacteria |

24 In which experiment does the metal act as a catalyst?

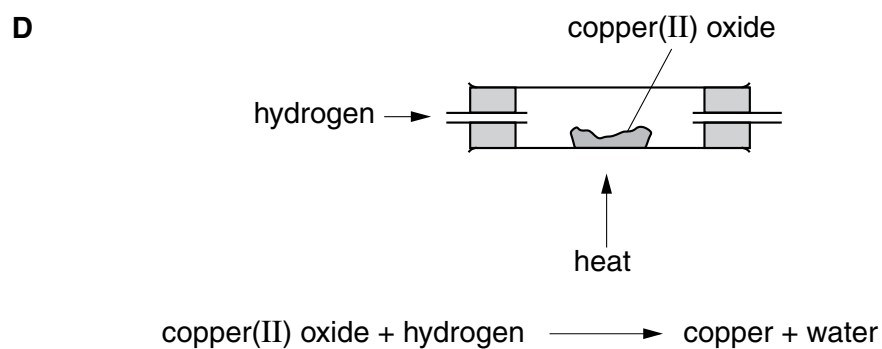
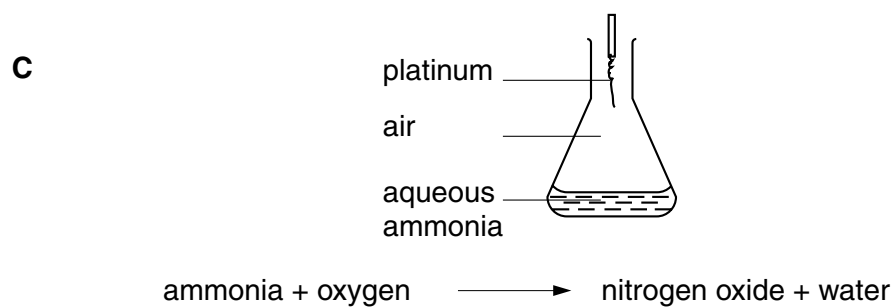
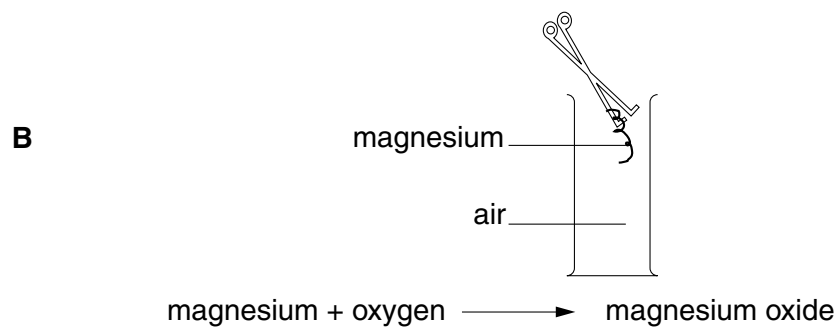
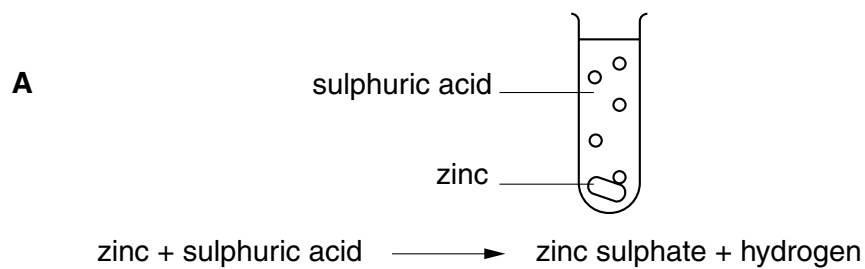

25 The diagram shows an experiment to investigate the effect of heat on potassium nitrate.

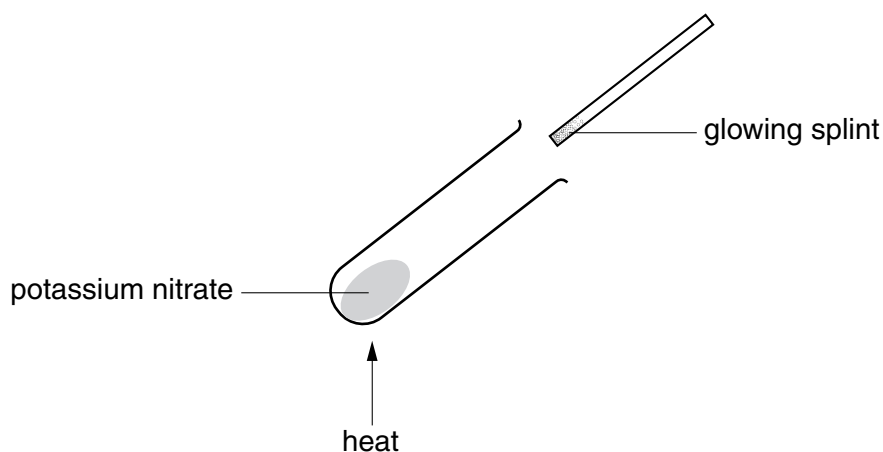

The glowing splint bursts into flame.

What happens to the potassium nitrate when it is heated?

| | type of reaction | gas produced |
|----------|-----------------------|--------------|
| A | combustion | hydrogen |
| B | combustion | oxygen |
| C | thermal decomposition | hydrogen |
| D | thermal decomposition | oxygen |

26 The description below of a plastic is incomplete.

To make a plastic,1..... of a2..... combine to form a long chain3.....

Which words correctly complete the gaps?

| | gap 1 | gap 2 | gap 3 |
|----------|-----------|---------|---------|
| A | atoms | monomer | polymer |
| B | atoms | polymer | monomer |
| C | molecules | monomer | polymer |
| D | molecules | polymer | monomer |

27 Why is water often used to extinguish fires?

- A The boiling point of water is 100°C .
- B Water is a compound containing oxygen and hydrogen.
- C Water removes heat from the fire.
- D Water reacts with most fuels.

28 A glass tank contains some water.

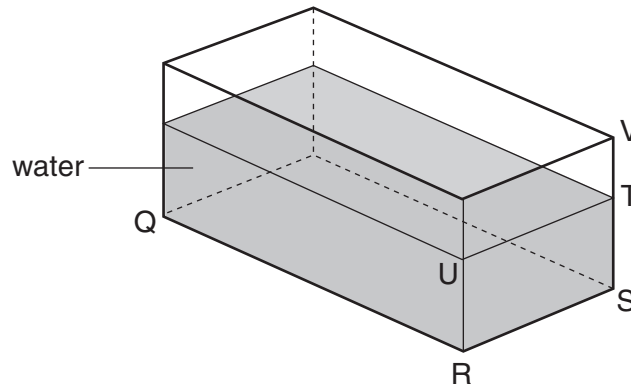

The length QR and the width RS of the tank are known.

What other distance needs to be measured in order to be able to calculate the volume of the water?

- A ST
- B SV
- C TU
- D TV

29 A tunnel has a length of 50 km. A car takes 20 min to travel between the two ends of the tunnel.

What is the average speed of the car?

- A 2.5 km/h
- B 16.6 km/h
- C 150 km/h
- D 1000 km/h

30 Three children, X, Y and Z, are using a see-saw to compare their weights.

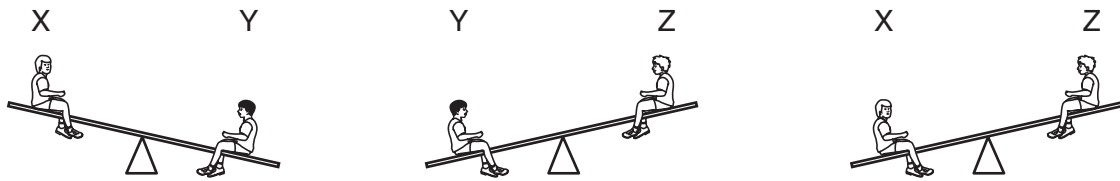

Which line in the table shows the correct order of the children's weights?

| | heaviest | ← → | lightest |
|----------|----------|-----|----------|
| A | X | Y | Z |
| B | X | Z | Y |
| C | Y | X | Z |
| D | Y | Z | X |

31 A spring is suspended from a stand. Loads are added and the extensions are measured.

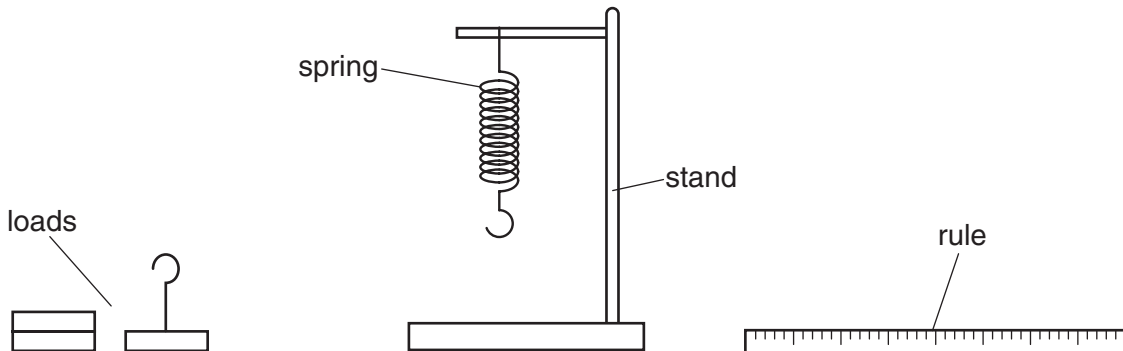

Which graph shows the result of plotting extension against load?

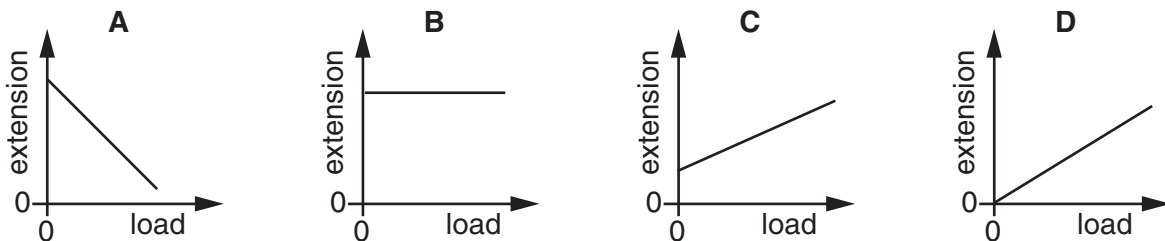

32 What is the source of the energy converted by a hydro-electric power station?

- A hot rocks
- B falling water
- C oil
- D waves

33 When water evaporates, some molecules escape.

Which molecules escape?

- A the molecules at the bottom of the liquid with less energy than others
- B the molecules at the bottom of the liquid with more energy than others
- C the molecules at the surface with less energy than others
- D the molecules at the surface with more energy than others

34 A person holds a glass beaker in one hand and fills it quickly with hot water. It takes several seconds before his hand starts to feel the heat.

Why is there this delay?

- A Glass is a poor conductor of heat.
- B Glass is a good conductor of heat.
- C Water is a poor conductor of heat.
- D Water is a good conductor of heat.

35 A woman tunes her radio to a station broadcasting on 200 m.

What does the 200 m tell her about the radio wave?

- A its amplitude
- B its frequency
- C its speed
- D its wavelength

36 Which diagram correctly shows rays passing through a camera lens?

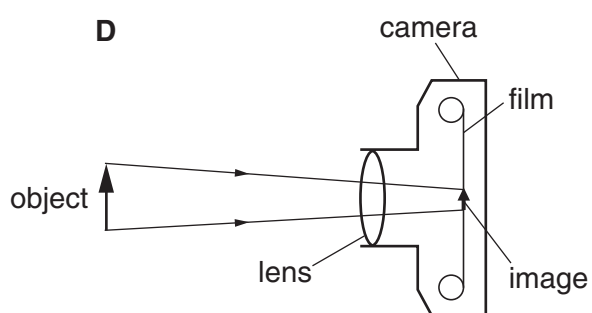
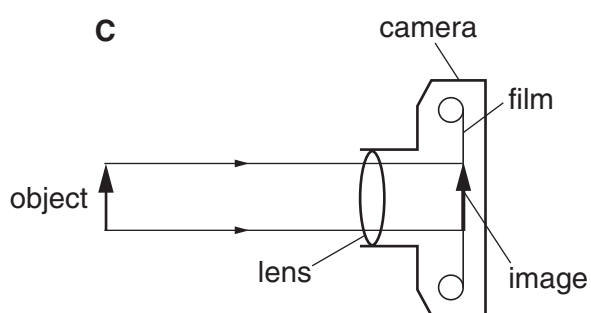
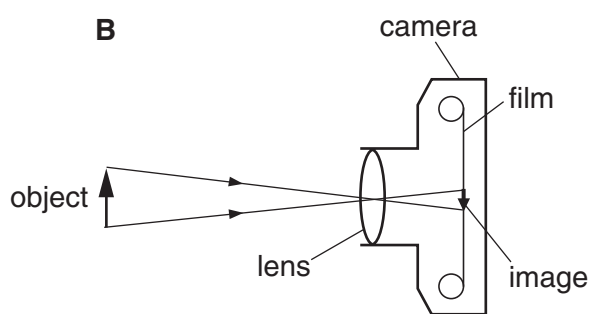
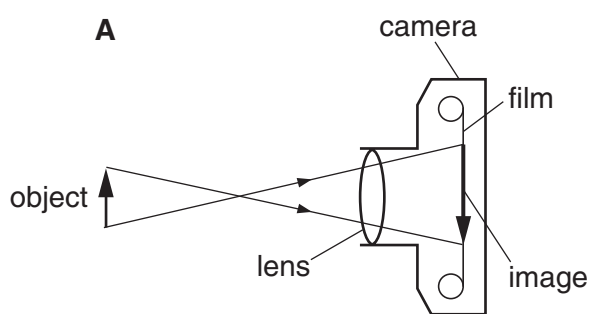

37 When the potential difference (p.d.) across a piece of resistance wire is changed, the current through the wire also changes.

The temperature of the wire is kept the same.

Which graph shows how the p.d. and current are related?

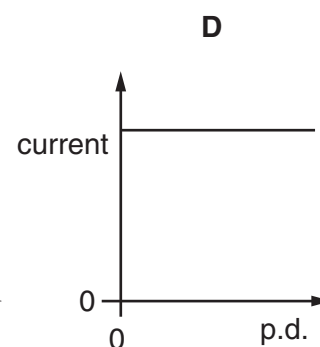
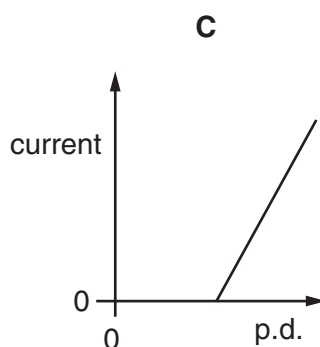
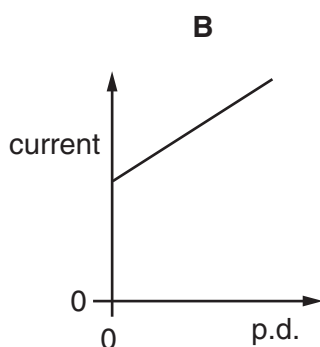
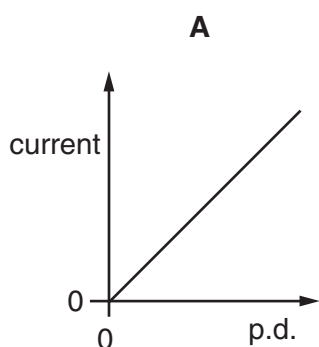

- 38 Two faulty ammeters and two perfect ammeters are connected in series in the circuit shown.

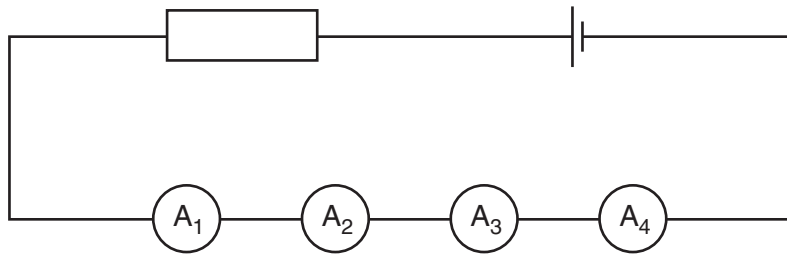

The readings on the ammeters are

- A_1 2.9 A
- A_2 3.1 A
- A_3 3.1 A
- A_4 3.3 A

Which two ammeters are faulty?

- A** A_1 and A_2 **B** A_1 and A_4 **C** A_2 and A_3 **D** A_3 and A_4
- 39 The diagram shows a transformer with an alternating voltage of 100 V applied to the primary coil.

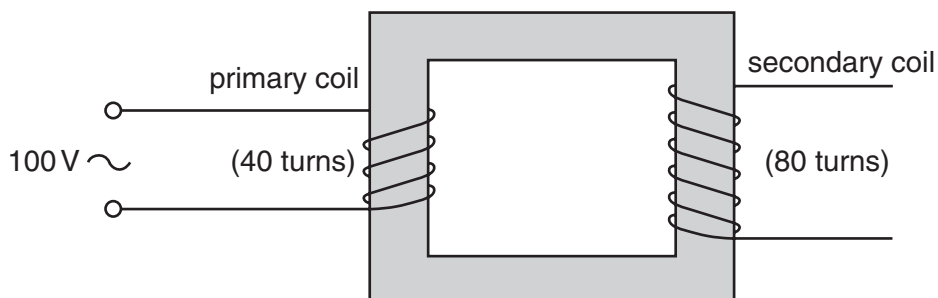

What is the voltage produced across the secondary coil?

- A** 50 V **B** 100 V **C** 200 V **D** 8000 V
- 40 Which type of radiation can be stopped by a sheet of paper?
- A** α -particles
 - B** β -particles
 - C** γ -rays
 - D** X-ray

DATA SHEET
The Periodic Table of the Elements
Group

| I | II | III | IV | V | VI | VII | O | | | | | | | | | | | | | | | | | | | | | | | | | | | | |
|---|---------------------------------------|-------------------------------------|-------------------------------------|------------------------------------|------------------------------------|-------------------------------------|------------------------------------|--------------------------------------|---------------------------------------|------------------------------------|--|-------------------------------------|---------------------------------------|-------------------------------------|----------------------------------|-------------------------------------|----------------------------------|---------------------------------|----------------------------------|------------------------------------|-----------------------------------|----------------------------------|---------------------------------------|---------------------------------|------------------------------------|------------------------------------|------------------------------------|---------------------------------|------------------------------------|--------------------------------------|--------------------------------------|------------------------------------|--|-------------------------------------|---------------------------------------|
| 7 Li Lithium 3 | 9 Be Beryllium 4 | 11 B Boron 5 | 12 C Carbon 6 | 14 N Nitrogen 7 | 16 O Oxygen 8 | 19 F Fluorine 9 | 20 Ne Neon 10 | | | | | | | | | | | | | | | | | | | | | | | | | | | | |
| 23 Na Sodium 11 | 24 Mg Magnesium 12 | 27 Al Aluminium 13 | 28 Si Silicon 14 | 31 P Phosphorus 15 | 32 S Sulphur 16 | 35.5 Cl Chlorine 17 | 40 Ar Argon 18 | | | | | | | | | | | | | | | | | | | | | | | | | | | | |
| 39 K Potassium 19 | 40 Ca Calcium 20 | 45 Sc Scandium 21 | 48 Ti Titanium 22 | 59 Co Cobalt 27 | 64 Cu Copper 29 | 79 Se Selenium 34 | 84 Kr Krypton 36 | | | | | | | | | | | | | | | | | | | | | | | | | | | | |
| 85 Rb Rubidium 37 | 88 Sr Strontium 38 | 89 Y Yttrium 39 | 91 Zr Zirconium 40 | 103 Rh Rhodium 45 | 108 Ag Silver 47 | 128 Te Tellurium 52 | 131 Xe Xenon 54 | | | | | | | | | | | | | | | | | | | | | | | | | | | | |
| 133 Cs Caesium 55 | 137 Ba Barium 56 | 139 La Lanthanum 57 | 178 Hf Hafnium 72 | 192 Ir Iridium 77 | 197 Au Gold 79 | 209 Po Polonium 84 | 226 Ra Radium 88 | | | | | | | | | | | | | | | | | | | | | | | | | | | | |
| 227 Ac Actinium 89 | 227 Fr Francium 87 | 227 Fr Francium 87 | 227 Ac Actinium 89 | 227 Fr Francium 87 | 227 Ac Actinium 89 | 227 Fr Francium 87 | 227 Ac Actinium 89 | | | | | | | | | | | | | | | | | | | | | | | | | | | | |
| <table border="1" style="width: 100%; border-collapse: collapse; text-align: center;"> <tr> <td>1 H Hydrogen 1</td> <td>2 He Helium 2</td> </tr> </table> | | | | | | | | 1 H Hydrogen 1 | 2 He Helium 2 | | | | | | | | | | | | | | | | | | | | | | | | | | |
| 1 H Hydrogen 1 | 2 He Helium 2 | | | | | | | | | | | | | | | | | | | | | | | | | | | | | | | | | | |
| <table border="1" style="width: 100%; border-collapse: collapse; text-align: center;"> <tr> <td>58 Ce Cerium 58</td> <td>59 Pr Praseodymium 59</td> <td>60 Nd Neodymium 60</td> <td>61 Pm Promethium 61</td> <td>62 Sm Samarium 62</td> <td>63 Eu Europium 63</td> <td>64 Gd Gadolinium 64</td> <td>65 Tb Terbium 65</td> <td>66 Dy Dysprosium 66</td> <td>67 Ho Holmium 67</td> <td>68 Er Erbium 68</td> <td>69 Tm Thulium 69</td> <td>70 Yb Ytterbium 70</td> <td>71 Lu Lutetium 71</td> </tr> <tr> <td>90 Th Thorium 90</td> <td>91 Pa Protactinium 91</td> <td>92 U Uranium 92</td> <td>93 Np Neptunium 93</td> <td>94 Pu Plutonium 94</td> <td>95 Am Americium 95</td> <td>96 Cm Curium 96</td> <td>97 Bk Berkelium 97</td> <td>98 Cf Californium 98</td> <td>99 Es Einsteinium 99</td> <td>100 Fm Fermium 100</td> <td>101 Md Mendelevium 101</td> <td>102 No Nobelium 102</td> <td>103 Lr Lawrencium 103</td> </tr> </table> | | | | | | | | 58 Ce Cerium 58 | 59 Pr Praseodymium 59 | 60 Nd Neodymium 60 | 61 Pm Promethium 61 | 62 Sm Samarium 62 | 63 Eu Europium 63 | 64 Gd Gadolinium 64 | 65 Tb Terbium 65 | 66 Dy Dysprosium 66 | 67 Ho Holmium 67 | 68 Er Erbium 68 | 69 Tm Thulium 69 | 70 Yb Ytterbium 70 | 71 Lu Lutetium 71 | 90 Th Thorium 90 | 91 Pa Protactinium 91 | 92 U Uranium 92 | 93 Np Neptunium 93 | 94 Pu Plutonium 94 | 95 Am Americium 95 | 96 Cm Curium 96 | 97 Bk Berkelium 97 | 98 Cf Californium 98 | 99 Es Einsteinium 99 | 100 Fm Fermium 100 | 101 Md Mendelevium 101 | 102 No Nobelium 102 | 103 Lr Lawrencium 103 |
| 58 Ce Cerium 58 | 59 Pr Praseodymium 59 | 60 Nd Neodymium 60 | 61 Pm Promethium 61 | 62 Sm Samarium 62 | 63 Eu Europium 63 | 64 Gd Gadolinium 64 | 65 Tb Terbium 65 | 66 Dy Dysprosium 66 | 67 Ho Holmium 67 | 68 Er Erbium 68 | 69 Tm Thulium 69 | 70 Yb Ytterbium 70 | 71 Lu Lutetium 71 | | | | | | | | | | | | | | | | | | | | | | |
| 90 Th Thorium 90 | 91 Pa Protactinium 91 | 92 U Uranium 92 | 93 Np Neptunium 93 | 94 Pu Plutonium 94 | 95 Am Americium 95 | 96 Cm Curium 96 | 97 Bk Berkelium 97 | 98 Cf Californium 98 | 99 Es Einsteinium 99 | 100 Fm Fermium 100 | 101 Md Mendelevium 101 | 102 No Nobelium 102 | 103 Lr Lawrencium 103 | | | | | | | | | | | | | | | | | | | | | | |

*58-71 Lanthanoid series
†90-103 Actinoid series

Key

| | |
|--------------------------|----------------------------|
| a | X |
| a = relative atomic mass | X = atomic symbol |
| b | b = proton (atomic) number |

The volume of one mole of any gas is 24 dm³ at room temperature and pressure (r.t.p.).