

# SYLLABUS

Cambridge IGCSE<sup>®</sup>

Physics

**0625**

For examination in June and November 2015

This syllabus is approved for use in England, Wales and Northern Ireland as a Cambridge International Level 1/Level 2 Certificate (QN: 500/5660/8).

## Changes to syllabus for 2015

This syllabus has been updated, but there are no significant changes to the syllabus content.

The standard electrical symbols candidates are expected to be able to recall and use are included in Section 8.1.

The mathematical requirements of the syllabus have been clarified (see Section 8.5) and guidance on the presentation of data has been included (see Section 8.7). The additional guidance regarding the expectations of the practical test (Paper 5) has been updated (see Section 7.2).

▮ Significant changes are indicated by black vertical lines either side of the text. ▮

Cambridge International Examinations retains the copyright on all its publications. Registered Centres are permitted to copy material from this booklet for their own internal use. However, we cannot give permission to Centres to photocopy any material that is acknowledged to a third party even for internal use within a Centre.

® IGCSE is the registered trademark of Cambridge International Examinations.

© Cambridge International Examinations 2013

---

# Contents

---

1. Introduction .....	2
1.1 Why choose Cambridge?	
1.2 Why choose Cambridge IGCSE?	
1.3 Why choose Cambridge IGCSE Physics?	
1.4 Cambridge ICE (International Certificate of Education)	
1.5 How can I find out more?	
2. Teacher support.....	6
2.1 Support materials	
2.2 Resource lists	
2.3 Training	
3. Syllabus content at a glance .....	7
4. Assessment at a glance .....	8
5. Syllabus aims and assessment objectives .....	10
5.1 Syllabus aims	
5.2 Assessment objectives	
5.3 Scheme of assessment	
5.4 Relationship between assessment objectives and components	
5.5 Grade descriptions	
5.6 Conventions (e.g. signs, symbols, terminology and nomenclature)	
6. Syllabus content .....	17
7. Practical assessment.....	32
7.1 Paper 4: Coursework	
7.2 Paper 5: Practical Test	
7.3 Paper 6: Alternative to Practical	
8. Appendix.....	39
8.1 Electrical symbols	
8.2 Symbols, units and definitions of physical quantities	
8.3 Safety in the laboratory	
8.4 Glossary of terms used in science papers	
8.5 Mathematical requirements	
8.6 ICT	
8.7 Presentation of data	
8.8 Forms	
9. Other information .....	53
10. Additional information for England, Wales and Northern Ireland.....	54

---

# 1. Introduction

---

## 1.1 Why choose Cambridge?

### Recognition

Cambridge International Examinations is the world's largest provider of international education programmes and qualifications for learners aged 5 to 19. We are part of Cambridge Assessment, a department of the University of Cambridge, trusted for excellence in education. Our qualifications are recognised by the world's universities and employers.

Cambridge IGCSE® (International General Certificate of Secondary Education) is internationally recognised by schools, universities and employers as equivalent in demand to UK GCSEs. Learn more at [www.cie.org.uk/recognition](http://www.cie.org.uk/recognition)

### Excellence in education

Our mission is to deliver world-class international education through the provision of high-quality curricula, assessment and services.

More than 9000 schools are part of our Cambridge learning community. We support teachers in over 160 countries who offer their learners an international education based on our curricula and leading to our qualifications. Every year, thousands of learners use Cambridge qualifications to gain places at universities around the world.

Our syllabuses are reviewed and updated regularly so that they reflect the latest thinking of international experts and practitioners and take account of the different national contexts in which they are taught.

Cambridge programmes and qualifications are designed to support learners in becoming:

- **confident** in working with information and ideas – their own and those of others
- **responsible** for themselves, responsive to and respectful of others
- **reflective** as learners, developing their ability to learn
- **innovative** and equipped for new and future challenges
- **engaged** intellectually and socially, ready to make a difference.

### Support for teachers

A wide range of materials and resources is available to support teachers and learners in Cambridge schools. Resources suit a variety of teaching methods in different international contexts. Through subject discussion forums and training, teachers can access the expert advice they need for teaching our qualifications. More details can be found in Section 2 of this syllabus and at [www.cie.org.uk/teachers](http://www.cie.org.uk/teachers)

### Support for exams officers

Exams officers can trust in reliable, efficient administration of exams entries and excellent personal support from our customer services. Learn more at [www.cie.org.uk/examsOfficers](http://www.cie.org.uk/examsOfficers)

## Not-for-profit, part of the University of Cambridge

We are a not-for-profit organisation where the needs of the teachers and learners are at the core of what we do. We continually invest in educational research and respond to feedback from our customers in order to improve our qualifications, products and services.

Our systems for managing the provision of international qualifications and education programmes for learners aged 5 to 19 are certified as meeting the internationally recognised standard for quality management, ISO 9001:2008. Learn more at [www.cie.org.uk/ISO9001](http://www.cie.org.uk/ISO9001)

## 1.2 Why choose Cambridge IGCSE?

Cambridge IGCSEs are international in outlook, but retain a local relevance. The syllabuses provide opportunities for contextualised learning and the content has been created to suit a wide variety of schools, avoid cultural bias and develop essential lifelong skills, including creative thinking and problem-solving.

Our aim is to balance knowledge, understanding and skills in our programmes and qualifications to enable candidates to become effective learners and to provide a solid foundation for their continuing educational journey.

Through our professional development courses and our support materials for Cambridge IGCSEs, we provide the tools to enable teachers to prepare learners to the best of their ability and work with us in the pursuit of excellence in education.

Cambridge IGCSEs are considered to be an excellent preparation for Cambridge International AS and A Levels, the Cambridge AICE (Advanced International Certificate of Education) Group Award, Cambridge Pre-U, and other education programmes, such as the US Advanced Placement program and the International Baccalaureate Diploma programme. Learn more about Cambridge IGCSEs at [www.cie.org.uk/cambridgesecondary2](http://www.cie.org.uk/cambridgesecondary2)

## Guided learning hours

Cambridge IGCSE syllabuses are designed on the assumption that candidates have about 130 guided learning hours per subject over the duration of the course, but this is for guidance only. The number of hours required to gain the qualification may vary according to local curricular practice and the learners' prior experience of the subject.

## 1.3 Why choose Cambridge IGCSE Physics?

Cambridge IGCSE Physics is accepted by universities and employers as proof of knowledge and understanding of physics. Successful candidates gain lifelong skills, including:

- an understanding of the usefulness (and limitations) of scientific method, and its application in other subjects and in everyday life
- a concern for accuracy and precision
- an understanding of the importance of safe practice
- an awareness of the importance of objectivity, integrity, enquiry, initiative and inventiveness

Cambridge IGCSE Physics also provides opportunities for students to:

- become confident in a technological world, with an informed interest in scientific matters
- develop an understanding of how scientific theories and methods have developed, and continue to develop, as a result of groups and individuals working together
- understand that the study and practice of science are affected and limited by social, economic, technological, ethical and cultural factors
- develop an awareness that the application of science in everyday life may be both helpful and harmful to the individual, the community and the environment
- appreciate that science overcomes national boundaries and that the language of science, used correctly and thoroughly, is universal
- develop an interest in, and care for, the environment

## Recommended prior learning

We recommend that candidates who are beginning this course should have previously studied a science curriculum such as that of the Cambridge Lower Secondary Programme or equivalent national educational frameworks. Candidates should also have adequate mathematical skills for the content contained in this syllabus.

## Progression

Cambridge IGCSE Certificates are general qualifications that enable candidates to progress either directly to employment, or to proceed to further qualifications. Cambridge IGCSE Physics provides an excellent foundation for advanced study in pure sciences, in applied science or in science-dependent vocational courses

Candidates who are awarded grades A\* to C in IGCSE Physics are well prepared to follow courses leading to Cambridge International AS and A Level Physics, or the equivalent.

## 1.4 Cambridge ICE (International Certificate of Education)

Cambridge ICE is a group award for Cambridge IGCSE. It gives schools the opportunity to benefit from offering a broad and balanced curriculum by recognising the achievements of learners who pass examinations in at least seven subjects. To qualify for the Cambridge ICE award learners are required to have studied subjects from five groups: two languages from Group I, and one subject from each of the remaining four groups. The seventh subject can be taken from any of the five subject groups.

Physics (0625) is in Group III, Science.

Learn more about Cambridge ICE at [www.cie.org.uk/cambridgesecondary2](http://www.cie.org.uk/cambridgesecondary2)

The Cambridge ICE is awarded from examinations administered in the June and November series each year.

Detailed timetables are available from [www.cie.org.uk/examsOfficers](http://www.cie.org.uk/examsOfficers)

## 1.5 How can I find out more?

### If you are already a Cambridge school

You can make entries for this qualification through your usual channels. If you have any questions, please contact us at **info@cie.org.uk**

### If you are not yet a Cambridge school

Learn about the benefits of becoming a Cambridge school at **www.cie.org.uk/startcambridge**. Email us at **info@cie.org.uk** to find out how your organisation can register to become a Cambridge school.

---

## 2. Teacher support

---

### 2.1 Support materials

Cambridge syllabuses, past question papers and examiner reports to cover the last examination series are on the *Syllabus and Support Materials* DVD, which we send to all Cambridge schools.

You can also go to our public website at [www.cie.org.uk/igcse](http://www.cie.org.uk/igcse) to download current and future syllabuses together with specimen papers or past question papers and examiner reports from one series.

For teachers at registered Cambridge schools a range of additional support materials for specific syllabuses is available online. For Teacher Support go to <http://teachers.cie.org.uk> (username and password required).

### 2.2 Resource lists

We work with publishers providing a range of resources for our syllabuses including textbooks, websites, CDs etc. Any endorsed, recommended and suggested resources are listed on both our public website and on Teacher Support.

The resource lists can be filtered to show all resources or just those which are endorsed or recommended by Cambridge. Resources endorsed by Cambridge go through a detailed quality assurance process and are written to align closely with the Cambridge syllabus they support.

### 2.3 Training

We offer a range of support activities for teachers to ensure they have the relevant knowledge and skills to deliver our qualifications. See [www.cie.org.uk/events](http://www.cie.org.uk/events) for further information.



### 3. Syllabus content at a glance

All candidates study the following topics.

#### General physics

- length and time
- speed, velocity and acceleration
- mass and weight
- density
- energy, work and power
- pressure

#### Thermal physics

- simple kinetic molecular model of matter
- thermal properties
- transfer of thermal energy

#### Properties of waves, including light and sound

- general wave properties
- light
- sound

#### Electricity and magnetism

- simple phenomena of magnetism
- electrical quantities
- electric circuits
- dangers of electricity
- electromagnetic effects
- cathode-ray oscilloscopes

#### Atomic physics

- radioactivity
- the nuclear atom

## 4. Assessment at a glance

Cambridge IGCSE Physics candidates are awarded grades ranging from A\* to G.

Candidates expected to achieve grades D, E, F or G, study the Core syllabus content only and are eligible for grades C to G.

Candidates expected to achieve grade C or higher should study the Extended syllabus content, which comprises the Core and Supplement content; these candidates are eligible for all grades from A\* to G.

All candidates must enter for **three** papers.

All candidates take:		
<b>Paper 1</b> Multiple choice question paper Weighted at 30% of total available marks		45 minutes
and either:		or:
<b>Paper 2</b> Core theory paper Weighted at 50% of the total marks available	1 hour 15 minutes	<b>Paper 3</b> Extended theory paper Weighted at 50% of the total marks available
		1 hour 15 minutes
and either:	or:	or:
<b>Paper 4</b> Coursework Weighted at 20% of the total marks available	<b>Paper 5</b> Practical Test Weighted at 20% of the total marks available	<b>Paper 6</b> Alternative to Practical Weighted at 20% of the total marks available
	1 hour 15 minutes	1 hour

### Availability

This syllabus is examined in the May/June examination series and the October/November examination series.

Detailed timetables are available from [www.cie.org.uk/examsOfficers](http://www.cie.org.uk/examsOfficers)

This syllabus is available to private candidates.

## Combining this with other syllabuses

Candidates can combine this syllabus in an examination series with any other Cambridge syllabus, except:

- syllabuses with the same title at the same level
- 0652 Cambridge IGCSE Physical Science
- 0653 Cambridge IGCSE Combined Science
- 0654 Cambridge IGCSE Co-ordinated Sciences (Double Award)
- 5124 Cambridge O Level Science (Physics, Chemistry)
- 5125 Cambridge O Level Science (Physics, Biology)
- 5129 Cambridge O Level Combined Science
- 5130 Cambridge O Level Additional Combined Science

Please note that Cambridge IGCSE, Cambridge International Level 1/Level 2 Certificate and Cambridge O Level syllabuses are at the same level.

---

## 5. Syllabus aims and assessment objectives

---

### 5.1 Syllabus aims

The aims of the syllabus listed below describe the educational purposes of this examination. The aims of the syllabus are the same for all students and are not listed in order of priority.

The aims are:

1. to provide a worthwhile educational experience for all candidates, through well designed studies of experimental and practical science, whether or not they go on to study science beyond this level
2. to enable candidates to acquire sufficient understanding and knowledge to:
  - become confident citizens in a technological world, to take or develop an informed interest in scientific matters
  - recognise the usefulness, and limitations, of scientific method and to appreciate its applicability in other disciplines and in everyday life
  - be suitably prepared for studies beyond Cambridge IGCSE in pure sciences, in applied sciences or in science-dependent vocational courses
3. to develop abilities and skills that:
  - are relevant to the study and practice of physics
  - are useful in everyday life
  - encourage safe practice
  - encourage effective communication
4. to develop attitudes relevant to physics such as:
  - concern for accuracy and precision
  - objectivity
  - integrity
  - enquiry
  - initiative
  - inventiveness
5. to stimulate interest in, and care for, the environment
6. to promote an awareness that:
  - scientific theories and methods have developed, and continue to develop, as a result of co-operative activities of groups and individuals
  - the study and practice of science are subject to social, economic, technological, ethical and cultural influences and limitations
  - the applications of science may be both beneficial and detrimental to the individual, the community and the environment
  - science transcends national boundaries and that the language of science, correctly and rigorously applied, is universal

## 5.2 Assessment objectives

The three assessment objectives in Cambridge IGCSE Physics are:

- A: Knowledge with understanding
- B: Handling information and problem solving
- C: Experimental skills and investigations

### A: Knowledge with understanding

Candidates should be able to demonstrate knowledge and understanding of:

- scientific phenomena, facts, laws, definitions, concepts, theories
- scientific vocabulary, terminology, conventions (including symbols, quantities and units)
- scientific instruments and apparatus, including techniques of operation and aspects of safety
- scientific quantities and their determination
- scientific and technological applications with their social, economic and environmental implications.

The syllabus content defines the factual material that candidates may be required to recall and explain.

Candidates will also be asked questions which require them to apply this material to unfamiliar contexts and to apply knowledge from one area of the syllabus to knowledge of a different syllabus area.

Questions testing these objectives will often begin with one of the following words: *define, state, describe, explain (using your knowledge and understanding) or outline* (see Glossary of terms).

### B: Handling information and problem solving

In words or using other written forms of presentation (e.g. symbolic, graphical and numerical), candidates should be able to:

- locate, select, organise and present information from a variety of sources
- translate information from one form to another
- manipulate numerical and other data
- use information to identify patterns, report trends and draw inferences
- present reasoned explanations of phenomena, patterns and relationships
- make predictions and hypotheses
- solve problems, including some of a quantitative nature.

Questions testing these skills may be based on information that is unfamiliar to candidates, requiring them to apply the principles and concepts from the syllabus to a new situation, in a logical, reasoned or deductive way.

Questions testing these skills will often begin with one of the following words: *predict, suggest, calculate or determine* (see Glossary of terms).

## C: Experimental skills and investigations

Candidates should be able to:

- know how to use techniques, apparatus, and materials (including following a sequence of instructions, where appropriate)
- make and record observations and measurements
- interpret and evaluate experimental observations and data
- plan investigations, evaluate methods and suggest possible improvements (including the selection of techniques, apparatus and materials).

### 5.3 Scheme of assessment

All candidates must enter for three papers: Paper 1; one from either Paper 2 or Paper 3; and one from Papers 4, 5 or 6.

Candidates who have only studied the Core syllabus content, or who are expected to achieve a grade D or below, should normally be entered for Paper 2.

Candidates who have studied the Extended syllabus content, and who are expected to achieve a grade C or above, should be entered for Paper 3.

All candidates must take a practical paper, chosen from: Paper 4 (Coursework), Paper 5 (Practical Test), or Paper 6 (Alternative to Practical).

All candidates take:		
<b>Paper 1</b> A multiple-choice paper consisting of 40 items of the four-choice type. This paper will test skills mainly in assessment objectives A and B. Questions will be based on the Core syllabus content and will be of a difficulty appropriate to grades C to G. 40 marks This paper will be weighted at 30% of the final total marks available.		45 minutes
and either:		or:
<b>Paper 2</b> Written paper consisting of short-answer and structured questions. Questions will be based on the Core syllabus content and will be of a difficulty appropriate to grades C to G.  Questions will test skills mainly in assessment objectives A and B.  80 marks This paper will be weighted at 50% of the total marks available.	1 hour 15 minutes	<b>Paper 3</b> Written paper consisting of short-answer and structured questions. Questions will be based on the Extended syllabus content and will be of a difficulty appropriate to the higher grades. Questions will test skills mainly in assessment objectives A and B. A quarter of the marks available will be based on Core syllabus content and the remainder on the Supplement. 80 marks This paper will be weighted at 50% of the total marks available.
and either:	or:	or:
<b>Paper 4*</b> Coursework School-based assessment of practical skills.  48 marks This paper will be weighted at 20% of the total marks available.	<b>Paper 5*</b> Practical Test Questions covering experimental and observational skills.  40 marks This paper will be weighted at 20% of the total marks available.	<b>Paper 6*</b> Alternative to Practical Written paper designed to test familiarity with laboratory based procedures.  40 marks This paper will be weighted at 20% of the total marks available.

\* The purpose of this component is to test appropriate skills in assessment objective C. Candidates will not be required to use knowledge outside the Core syllabus content.

## 5.4 Relationship between assessment objectives and components

Assessment objective	Appropriate weighting
<b>A:</b> Knowledge with understanding	50% (not more than 25% recall)
<b>B:</b> Handling information and problem solving	30%
<b>C:</b> Experimental skills and investigations	20%

Teachers should take note that there is an equal weighting of 50% for skills (including handling information, problem solving, practical, experimental and investigative skills) and for knowledge and understanding. Teachers' schemes of work and the sequence of learning activities should reflect this balance, so that the aims of the syllabus may be met and the candidates are fully prepared for the assessment.

Assessment objective	Paper 1 (marks)	Papers 2 or 3 (marks)	Paper 4 (marks)	Papers 5 or 6 (mark)
<b>A:</b> Knowledge with understanding	25–30	44–50	0	0
<b>B:</b> Handling information and problem solving	10–15	30–36	0	0
<b>C:</b> Experimental skills and investigations	0	0	48	40



## 5.5 Grade descriptions

The scheme of assessment is intended to encourage positive achievement by all candidates.

<b>Grade A</b>	<b>Candidate must show mastery of the Core curriculum and the Extended curriculum</b>
A <b>Grade A</b> candidate will be able to:	<ul style="list-style-type: none"> <li>• relate facts to principles and theories and vice versa</li> <li>• state why particular techniques are preferred for a procedure or operation</li> <li>• select and collate information from a number of sources and present it in a clear logical form</li> <li>• solve problems in situations which may involve a wide range of variables</li> <li>• process data from a number of sources to identify any patterns or trends</li> <li>• generate a hypothesis to explain facts, or find facts to support a hypothesis</li> </ul>
<b>Grade C</b>	<b>Candidate must show mastery of the Core curriculum, plus some ability to answer questions which are aimed at a higher level.</b>
A <b>Grade C</b> candidate will be able to:	<ul style="list-style-type: none"> <li>• link facts to situations not specified in the syllabus</li> <li>• describe the correct procedure(s) for a multi-stage operation</li> <li>• select a range of information from a given source and present it in a clear logical form</li> <li>• identify patterns or trends in given information</li> <li>• solve a problem involving more than one step, but with a limited range of variables</li> <li>• generate a hypothesis to explain a given set of facts or data</li> </ul>
<b>Grade F</b>	<b>Candidate must show competence in answering questions based on the Core curriculum.</b>
A <b>Grade F</b> candidate will be able to:	<ul style="list-style-type: none"> <li>• recall facts contained in the syllabus</li> <li>• indicate the correct procedure for a single operation</li> <li>• select and present a single piece of information from a given source</li> <li>• solve a problem involving one step, or more than one step if structured help is given</li> <li>• identify a pattern or trend where only minor manipulation of data is needed</li> <li>• recognise which of two given hypotheses explains a set of facts or data</li> </ul>

## 5.6 Conventions (e.g. signs, symbols, terminology and nomenclature)

The syllabus and question papers will conform with generally accepted international practice.

In particular, please note the following documents, published in the UK, which will be used as guidelines:

Reports produced by the Association for Science Education (ASE):

- *SI Units, Signs, Symbols and Abbreviations* (1981)
- *Signs, Symbols and Systematics: The ASE Companion to 16–19 Science* (2000)

### Litre/dm<sup>3</sup>

To avoid any confusion concerning the symbol for litre, **dm<sup>3</sup>** will be used in place of l or litre.

### Decimal markers

In accordance with current ASE convention, decimal markers in examination papers will be a single dot on the line. Candidates are expected to follow this convention in their answers.

### Numbers

Numbers from 1000 to 9999 will be printed without commas or spaces. Numbers greater than or equal to 10 000 will be printed without commas. A space will be left between each group of three whole numbers, e.g. 4 256 789.

## 6. Syllabus content

All candidates should be taught the Core syllabus content. Candidates who are only taught the Core syllabus content can achieve a maximum grade C. Candidates aiming for grades A\* to C should be taught the Extended syllabus content. The Extended syllabus content includes both the Core and the Supplement syllabus content.

Throughout the course, teachers should aim to show the relevance of concepts to the candidates' everyday life and current technology. To encourage this approach and to allow teachers to use flexible programs to meet the course's general aims, we have limited the specified content of the syllabus. The following material should therefore be regarded as an exam syllabus rather than a teaching syllabus.

1. General physics	
<p>1.1 Length and time</p> <p><b>Core</b></p> <ul style="list-style-type: none"> <li>Use and describe the use of rules and measuring cylinders to calculate a length or a volume</li> <li>Use and describe the use of clocks and devices for measuring an interval of time</li> </ul>	<p><b>Supplement</b></p> <ul style="list-style-type: none"> <li>Use and describe the use of a mechanical method for the measurement of a small distance (including use of a micrometer screw gauge)</li> <li>Measure and describe how to measure a short interval of time (including the period of a pendulum)</li> </ul>
<p>1.2 Speed, velocity and acceleration</p> <p><b>Core</b></p> <ul style="list-style-type: none"> <li>Define speed and calculate speed from <math>\frac{\text{total distance}}{\text{total time}}</math></li> <li>Plot and interpret a speed/time graph or a distance/time graph</li> <li>Recognise from the shape of a speed/time graph when a body is               <ul style="list-style-type: none"> <li>at rest</li> <li>moving with constant speed</li> <li>moving with changing speed</li> </ul> </li> <li>Calculate the area under a speed/time graph to work out the distance travelled for motion with constant acceleration</li> <li>Demonstrate some understanding that acceleration is related to changing speed</li> <li>State that the acceleration of free fall for a body near to the Earth is constant</li> </ul>	<p><b>Supplement</b></p> <ul style="list-style-type: none"> <li>Distinguish between speed and velocity</li> <li>Recognise linear motion for which the acceleration is constant and calculate the acceleration</li> <li>Recognise motion for which the acceleration is not constant</li> <li>Describe qualitatively the motion of bodies falling in a uniform gravitational field with and without air resistance (including reference to terminal velocity)</li> </ul>

<p>1.3 Mass and weight</p> <p><b>Core</b></p> <ul style="list-style-type: none"> <li>• Show familiarity with the idea of the mass of a body</li> <li>• State that weight is a force</li> <li>• Demonstrate understanding that weights (and hence masses) may be compared using a balance</li> </ul>	<p><b>Supplement</b></p> <ul style="list-style-type: none"> <li>• Demonstrate an understanding that mass is a property that 'resists' change in motion</li> <li>• Describe, and use the concept of, weight as the effect of a gravitational field on a mass</li> </ul>
<p>1.4 Density</p> <p><b>Core</b></p> <ul style="list-style-type: none"> <li>• Describe an experiment to determine the density of a liquid and of a regularly shaped solid and make the necessary calculation</li> </ul>	<p><b>Supplement</b></p> <ul style="list-style-type: none"> <li>• Describe the determination of the density of an irregularly shaped solid by the method of displacement, and make the necessary calculation</li> </ul>
<p>1.5 Forces</p>	
<p>1.5 (a) Effects of forces</p> <p><b>Core</b></p> <ul style="list-style-type: none"> <li>• State that a force may produce a change in size and shape of a body</li> <li>• Plot extension/load graphs and describe the associated experimental procedure</li> <li>• Describe the ways in which a force may change the motion of a body</li> <li>• Find the resultant of two or more forces acting along the same line</li> </ul>	<p><b>Supplement</b></p> <ul style="list-style-type: none"> <li>• Interpret extension/load graphs</li> <li>• State Hooke's Law and recall and use the expression <math>F = kx</math></li> <li>• Recognise the significance of the term 'limit of proportionality' for an extension/load graph</li> <li>• Recall and use the relation between force, mass and acceleration (including the direction)</li> <li>• Describe qualitatively motion in a curved path due to a perpendicular force (<math>F = mv^2/r</math> is <i>not</i> required)</li> </ul>
<p>1.5 (b) Turning effect</p> <p><b>Core</b></p> <ul style="list-style-type: none"> <li>• Describe the moment of a force as a measure of its turning effect and give everyday examples</li> <li>• Describe qualitatively the balancing of a beam about a pivot</li> </ul>	<p><b>Supplement</b></p> <ul style="list-style-type: none"> <li>• Perform and describe an experiment (involving vertical forces) to show that there is no net moment on a body in equilibrium</li> <li>• Apply the idea of opposing moments to simple systems in equilibrium</li> </ul>
<p>1.5 (c) Conditions for equilibrium</p> <p><b>Core</b></p> <ul style="list-style-type: none"> <li>• State that, when there is no resultant force and no resultant turning effect, a system is in equilibrium</li> </ul>	

<p>1.5 (d) Centre of mass</p> <p><b>Core</b></p> <ul style="list-style-type: none"> <li>• Perform and describe an experiment to determine the position of the centre of mass of a plane lamina</li> <li>• Describe qualitatively the effect of the position of the centre of mass on the stability of simple objects</li> </ul>	
<p>1.5 (e) Scalars and vectors</p>	<p><b>Supplement</b></p> <ul style="list-style-type: none"> <li>• Demonstrate an understanding of the difference between scalars and vectors and give common examples</li> <li>• Add vectors by graphical representation to determine a resultant</li> <li>• Determine graphically the resultant of two vectors</li> </ul>
<p>1.6 Energy, work and power</p>	
<p>1.6 (a) Energy</p> <p><b>Core</b></p> <ul style="list-style-type: none"> <li>• Demonstrate an understanding that an object may have energy due to its motion or its position, and that energy may be transferred and stored</li> <li>• Give examples of energy in different forms, including kinetic, gravitational, chemical, strain, nuclear, internal, electrical, light and sound</li> <li>• Give examples of the conversion of energy from one form to another, and of its transfer from one place to another</li> <li>• Apply the principle of energy conservation to simple examples</li> </ul>	<p><b>Supplement</b></p> <ul style="list-style-type: none"> <li>• Recall and use the expressions k.e. = <math>\frac{1}{2}mv^2</math> and p.e. = <math>mgh</math></li> </ul>

<p>1.6 (b) Energy resources</p> <p><b>Core</b></p> <ul style="list-style-type: none"> <li>• Distinguish between renewable and non-renewable sources of energy</li> <li>• Describe how electricity or other useful forms of energy may be obtained from: <ul style="list-style-type: none"> <li>– chemical energy stored in fuel</li> <li>– water, including the energy stored in waves, in tides, and in water behind hydroelectric dams</li> <li>– geothermal resources</li> <li>– nuclear fission</li> <li>– heat and light from the Sun (solar cells and panels)</li> </ul> </li> <li>• Give advantages and disadvantages of each method in terms of cost, reliability, scale and environmental impact</li> <li>• Show a qualitative understanding of efficiency</li> </ul>	<p><b>Supplement</b></p> <ul style="list-style-type: none"> <li>• Show an understanding that energy is released by nuclear fusion in the Sun</li> <li>• Recall and use the equation: <math display="block">\text{efficiency} = \frac{\text{useful energy output}}{\text{energy input}} \times 100\%</math> </li> </ul>
<p>1.6 (c) Work</p> <p><b>Core</b></p> <ul style="list-style-type: none"> <li>• Relate (without calculation) work done to the magnitude of a force and the distance moved</li> </ul>	<p><b>Supplement</b></p> <ul style="list-style-type: none"> <li>• Describe energy changes in terms of work done</li> <li>• Recall and use <math>\Delta W = Fd = \Delta E</math></li> </ul>
<p>1.6 (d) Power</p> <p><b>Core</b></p> <ul style="list-style-type: none"> <li>• Relate (without calculation) power to work done and time taken, using appropriate examples</li> </ul>	<p><b>Supplement</b></p> <ul style="list-style-type: none"> <li>• Recall and use the equation <math>P = E/t</math> in simple systems</li> </ul>
<p>1.7 Pressure</p> <p><b>Core</b></p> <ul style="list-style-type: none"> <li>• Relate (without calculation) pressure to force and area, using appropriate examples</li> <li>• Describe the simple mercury barometer and its use in measuring atmospheric pressure</li> <li>• Relate (without calculation) the pressure beneath a liquid surface to depth and to density, using appropriate examples</li> <li>• Use and describe the use of a manometer</li> </ul>	<p><b>Supplement</b></p> <ul style="list-style-type: none"> <li>• Recall and use the equation <math>p = F/A</math></li> <li>• Recall and use the equation <math>p = h\rho g</math></li> </ul>

2. Thermal physics	
2.1 Simple kinetic molecular model of matter	
2.1 (a) States of matter <b>Core</b> <ul style="list-style-type: none"> <li>State the distinguishing properties of solids, liquids and gases</li> </ul>	
2.1 (b) Molecular model <b>Core</b> <ul style="list-style-type: none"> <li>Describe qualitatively the molecular structure of solids, liquids and gases</li> <li>Interpret the temperature of a gas in terms of the motion of its molecules</li> <li>Describe qualitatively the pressure of a gas in terms of the motion of its molecules</li> <li>Describe qualitatively the effect of a change of temperature on the pressure of a gas at constant volume</li> <li>Show an understanding of the random motion of particles in a suspension as evidence for the kinetic molecular model of matter</li> <li>Describe this motion (sometimes known as Brownian motion) in terms of random molecular bombardment</li> </ul>	<b>Supplement</b> <ul style="list-style-type: none"> <li>Relate the properties of solids, liquids and gases to the forces and distances between molecules and to the motion of the molecules</li> <li>Show an appreciation that massive particles may be moved by light, fast-moving molecules</li> </ul>
2.1 (c) Evaporation <b>Core</b> <ul style="list-style-type: none"> <li>Describe evaporation in terms of the escape of more-energetic molecules from the surface of a liquid</li> <li>Relate evaporation to the consequent cooling</li> </ul>	<b>Supplement</b> <ul style="list-style-type: none"> <li>Demonstrate an understanding of how temperature, surface area and draught over a surface influence evaporation</li> </ul>
2.1 (d) Pressure changes <b>Core</b> <ul style="list-style-type: none"> <li>Relate the change in volume of a gas to change in pressure applied to the gas at constant temperature</li> </ul>	<b>Supplement</b> <ul style="list-style-type: none"> <li>Recall and use the equation <math>pV = \text{constant}</math> at constant temperature</li> </ul>

2.2 Thermal properties	
<p>2.2 (a) Thermal expansion of solids, liquids and gases</p> <p><b>Core</b></p> <ul style="list-style-type: none"> <li>Describe qualitatively the thermal expansion of solids, liquids and gases</li> <li>Identify and explain some of the everyday applications and consequences of thermal expansion</li> <li>Describe qualitatively the effect of a change of temperature on the volume of a gas at constant pressure</li> </ul>	<p><b>Supplement</b></p> <ul style="list-style-type: none"> <li>Show an appreciation of the relative order of magnitude of the expansion of solids, liquids and gases</li> </ul>
<p>2.2 (b) Measurement of temperature</p> <p><b>Core</b></p> <ul style="list-style-type: none"> <li>Appreciate how a physical property that varies with temperature may be used for the measurement of temperature, and state examples of such properties</li> <li>Recognise the need for and identify fixed points</li> <li>Describe the structure and action of liquid-in-glass thermometers</li> </ul>	<p><b>Supplement</b></p> <ul style="list-style-type: none"> <li>Demonstrate understanding of sensitivity, range and linearity</li> <li>Describe the structure of a thermocouple and show understanding of its use for measuring high temperatures and those that vary rapidly</li> </ul>
<p>2.2 (c) Thermal capacity</p> <p><b>Core</b></p> <ul style="list-style-type: none"> <li>Relate a rise in the temperature of a body to an increase in internal energy</li> <li>Show an understanding of the term thermal capacity</li> </ul>	<p><b>Supplement</b></p> <ul style="list-style-type: none"> <li>Describe an experiment to measure the specific heat capacity of a substance</li> </ul>
<p>2.2 (d) Melting and boiling</p> <p><b>Core</b></p> <ul style="list-style-type: none"> <li>Describe melting and boiling in terms of energy input without a change in temperature</li> <li>State the meaning of melting point and boiling point</li> <li>Describe condensation and solidification</li> </ul>	<p><b>Supplement</b></p> <ul style="list-style-type: none"> <li>Distinguish between boiling and evaporation</li> <li>Use the terms <i>latent heat of vaporisation</i> and <i>latent heat of fusion</i> and give a molecular interpretation of latent heat</li> <li>Describe an experiment to measure specific latent heats for steam and for ice</li> </ul>
2.3 Transfer of thermal energy	
<p>2.3 (a) Conduction</p> <p><b>Core</b></p> <ul style="list-style-type: none"> <li>Describe experiments to demonstrate the properties of good and bad conductors of heat</li> </ul>	<p><b>Supplement</b></p> <ul style="list-style-type: none"> <li>Give a simple molecular account of heat transfer in solids</li> </ul>



<p>2.3 (b) Convection</p> <p><b>Core</b></p> <ul style="list-style-type: none"> <li>Relate convection in fluids to density changes and describe experiments to illustrate convection</li> </ul>	
<p>2.3 (c) Radiation</p> <p><b>Core</b></p> <ul style="list-style-type: none"> <li>Identify infra-red radiation as part of the electromagnetic spectrum</li> </ul>	<p><b>Supplement</b></p> <ul style="list-style-type: none"> <li>Describe experiments to show the properties of good and bad emitters and good and bad absorbers of infra-red radiation</li> </ul>
<p>2.3 (d) Consequences of energy transfer</p> <p><b>Core</b></p> <ul style="list-style-type: none"> <li>Identify and explain some of the everyday applications and consequences of conduction, convection and radiation</li> </ul>	
<p><b>3. Properties of waves, including light and sound</b></p>	
<p>3.1 General wave properties</p> <p><b>Core</b></p> <ul style="list-style-type: none"> <li>Describe what is meant by wave motion as illustrated by vibration in ropes and springs and by experiments using water waves</li> <li>Use the term <i>wavefront</i></li> <li>Give the meaning of <i>speed</i>, <i>frequency</i>, <i>wavelength</i> and <i>amplitude</i></li> <li>Distinguish between transverse and longitudinal waves and give suitable examples</li> <li>Describe the use of water waves to show: <ul style="list-style-type: none"> <li>reflection at a plane surface</li> <li>refraction due to a change of speed</li> <li>diffraction produced by wide and narrow gaps</li> </ul> </li> </ul>	<p><b>Supplement</b></p> <ul style="list-style-type: none"> <li>Recall and use the equation <math>v = f \lambda</math></li> <li>Interpret reflection, refraction and diffraction using wave theory</li> </ul>
<p>3.2 Light</p>	
<p>3.2 (a) Reflection of light</p> <p><b>Core</b></p> <ul style="list-style-type: none"> <li>Describe the formation of an optical image by a plane mirror, and give its characteristics</li> <li>Use the law angle of incidence = angle of reflection</li> </ul>	<p><b>Supplement</b></p> <ul style="list-style-type: none"> <li>Perform simple constructions, measurements and calculations</li> </ul>

<p>3.2 (b) Refraction of light</p> <p><b>Core</b></p> <ul style="list-style-type: none"> <li>Describe an experimental demonstration of the refraction of light</li> <li>Use the terminology for the angle of incidence <math>i</math> and angle of refraction <math>r</math> and describe the passage of light through parallel-sided transparent material</li> <li>Give the meaning of <i>critical angle</i></li> <li>Describe internal and total internal reflection</li> </ul>	<p><b>Supplement</b></p> <ul style="list-style-type: none"> <li>Recall and use the definition of refractive index <math>n</math> in terms of speed</li> <li>Recall and use the equation <math>\sin i / \sin r = n</math></li> <li>Describe the action of optical fibres particularly in medicine and communications technology</li> </ul>
<p>3.2 (c) Thin converging lens</p> <p><b>Core</b></p> <ul style="list-style-type: none"> <li>Describe the action of a thin converging lens on a beam of light</li> <li>Use the terms <i>principal focus</i> and <i>focal length</i></li> <li>Draw ray diagrams to illustrate the formation of a real image by a single lens</li> </ul>	<p><b>Supplement</b></p> <ul style="list-style-type: none"> <li>Draw ray diagrams to illustrate the formation of a virtual image by a single lens</li> <li>Use and describe the use of a single lens as a magnifying glass</li> </ul>
<p>3.2 (d) Dispersion of light</p> <p><b>Core</b></p> <ul style="list-style-type: none"> <li>Give a qualitative account of the dispersion of light as shown by the action of a glass prism on light</li> </ul>	
<p>3.2 (e) Electromagnetic spectrum</p> <p><b>Core</b></p> <ul style="list-style-type: none"> <li>Describe the main features of the electromagnetic spectrum and state that all e.m. waves travel with the same high speed <i>in vacuo</i></li> <li>Describe the role of electromagnetic waves in: <ul style="list-style-type: none"> <li>radio and television communications (radio waves)</li> <li>satellite television and telephones (microwaves)</li> <li>electrical appliances, remote controllers for televisions and intruder alarms (infra-red)</li> <li>medicine and security (X-rays)</li> </ul> </li> <li>Demonstrate an awareness of safety issues regarding the use of microwaves and X-rays</li> </ul>	<p><b>Supplement</b></p> <ul style="list-style-type: none"> <li>State the approximate value of the speed of electromagnetic waves</li> <li>Use the term <i>monochromatic</i></li> </ul>

<p>3.3 Sound</p> <p><b>Core</b></p> <ul style="list-style-type: none"> <li>• Describe the production of sound by vibrating sources</li> <li>• Describe the longitudinal nature of sound waves</li> <li>• State the approximate range of audible frequencies</li> <li>• Show an understanding that a medium is needed to transmit sound waves</li> <li>• Describe an experiment to determine the speed of sound in air</li> <li>• Relate the loudness and pitch of sound waves to amplitude and frequency</li> <li>• Describe how the reflection of sound may produce an echo</li> </ul>	<p><b>Supplement</b></p> <ul style="list-style-type: none"> <li>• Describe compression and rarefaction</li> <li>• State the order of magnitude of the speed of sound in air, liquids and solids</li> </ul>
<p><b>4. Electricity and magnetism</b></p>	
<p>4.1 Simple phenomena of magnetism</p> <p><b>Core</b></p> <ul style="list-style-type: none"> <li>• State the properties of magnets</li> <li>• Give an account of induced magnetism</li> <li>• Distinguish between ferrous and non-ferrous materials</li> <li>• Describe methods of magnetisation and of demagnetisation</li> <li>• Describe an experiment to identify the pattern of field lines around a bar magnet</li> <li>• Distinguish between the magnetic properties of iron and steel</li> <li>• Distinguish between the design and use of permanent magnets and electromagnets</li> </ul>	

4.2 Electrical quantities	
<p>4.2 (a) Electric charge</p> <p><b>Core</b></p> <ul style="list-style-type: none"> <li>Describe simple experiments to show the production and detection of electrostatic charges</li> <li>State that there are positive and negative charges</li> <li>State that unlike charges attract and that like charges repel</li> <li>Describe an electric field as a region in which an electric charge experiences a force</li> <li>Distinguish between electrical conductors and insulators and give typical examples</li> </ul>	<p><b>Supplement</b></p> <ul style="list-style-type: none"> <li>State that charge is measured in coulombs</li> <li>State the direction of lines of force and describe simple field patterns, including the field around a point charge and the field between two parallel plates</li> <li>Give an account of charging by induction</li> <li>Recall and use the simple electron model to distinguish between conductors and insulators</li> </ul>
<p>4.2 (b) Current</p> <p><b>Core</b></p> <ul style="list-style-type: none"> <li>State that current is related to the flow of charge</li> <li>Use and describe the use of an ammeter</li> </ul>	<p><b>Supplement</b></p> <ul style="list-style-type: none"> <li>Show understanding that a current is a rate of flow of charge and recall and use the equation <math>I = Q/t</math></li> <li>Distinguish between the direction of flow of electrons and conventional current</li> </ul>
<p>4.2 (c) Electromotive force</p> <p><b>Core</b></p> <ul style="list-style-type: none"> <li>State that the electromotive force (e.m.f.) of a source of electrical energy is measured in volts</li> </ul>	<p><b>Supplement</b></p> <ul style="list-style-type: none"> <li>Show understanding that e.m.f. is defined in terms of energy supplied by a source in driving charge round a complete circuit</li> </ul>
<p>4.2 (d) Potential difference</p> <p><b>Core</b></p> <ul style="list-style-type: none"> <li>State that the potential difference across a circuit component is measured in volts</li> <li>Use and describe the use of a voltmeter</li> </ul>	

<p>4.2 (e) Resistance</p> <p><b>Core</b></p> <ul style="list-style-type: none"> <li>• State that resistance = p.d./current and understand qualitatively how changes in p.d. or resistance affect current</li> <li>• Recall and use the equation <math>R = V/I</math></li> <li>• Describe an experiment to determine resistance using a voltmeter and an ammeter</li> <li>• Relate (without calculation) the resistance of a wire to its length and to its diameter</li> </ul>	<p><b>Supplement</b></p> <ul style="list-style-type: none"> <li>• Recall and use quantitatively the proportionality between resistance and length, and the inverse proportionality between resistance and cross-sectional area of a wire</li> </ul>
<p>4.2 (f) Electrical energy</p>	<p><b>Supplement</b></p> <ul style="list-style-type: none"> <li>• Recall and use the equations <math>P = IV</math> and <math>E = IVt</math></li> </ul>
<p>4.3 Electric circuits</p>	
<p>4.3 (a) Circuit diagrams</p> <p><b>Core</b></p> <ul style="list-style-type: none"> <li>• Draw and interpret circuit diagrams containing sources, switches, resistors (fixed and variable), lamps, ammeters, voltmeters, magnetising coils, transformers, bells, fuses and relays</li> </ul>	<p><b>Supplement</b></p> <ul style="list-style-type: none"> <li>• Draw and interpret circuit diagrams containing diodes and transistors</li> </ul>
<p>4.3 (b) Series and parallel circuits</p> <p><b>Core</b></p> <ul style="list-style-type: none"> <li>• Understand that the current at every point in a series circuit is the same</li> <li>• Give the combined resistance of two or more resistors in series</li> <li>• State that, for a parallel circuit, the current from the source is larger than the current in each branch</li> <li>• State that the combined resistance of two resistors in parallel is less than that of either resistor by itself</li> <li>• State the advantages of connecting lamps in parallel in a lighting circuit</li> </ul>	<p><b>Supplement</b></p> <ul style="list-style-type: none"> <li>• Recall and use the fact that the sum of the p.d.s across the components in a series circuit is equal to the total p.d. across the supply</li> <li>• Recall and use the fact that the current from the source is the sum of the currents in the separate branches of a parallel circuit</li> <li>• Calculate the effective resistance of two resistors in parallel</li> </ul>

<p>4.3 (c) Action and use of circuit components</p> <p><b>Core</b></p> <ul style="list-style-type: none"> <li>Describe the action of a variable potential divider (potentiometer)</li> <li>Describe the action of thermistors and light-dependent resistors and show understanding of their use as input transducers</li> <li>Describe the action of a capacitor as an energy store and show understanding of its use in time-delay circuits</li> <li>Describe the action of a relay and show understanding of its use in switching circuits</li> </ul>	<p><b>Supplement</b></p> <ul style="list-style-type: none"> <li>Describe the action of a diode and show understanding of its use as a rectifier</li> <li>Describe the action of a transistor as an electrically operated switch and show understanding of its use in switching circuits</li> <li>Recognise and show understanding of circuits operating as light-sensitive switches and temperature-operated alarms (using a relay or a transistor)</li> </ul>
<p>4.3 (d) Digital electronics</p>	<p><b>Supplement</b></p> <ul style="list-style-type: none"> <li>Explain and use the terms <i>digital</i> and <i>analogue</i></li> <li>State that logic gates are circuits containing transistors and other components</li> <li>Describe the action of NOT, AND, OR, NAND and NOR gates</li> <li>Design and understand simple digital circuits combining several logic gates</li> <li>State and use the symbols for logic gates (candidates should use the American ANSI#Y 32.14 symbols)</li> </ul>
<p>4.4 Dangers of electricity</p> <p><b>Core</b></p> <ul style="list-style-type: none"> <li>state the hazards of: <ul style="list-style-type: none"> <li>damaged insulation</li> <li>overheating of cables</li> <li>damp conditions</li> </ul> </li> <li>Show an understanding of the use of fuses and circuit-breakers</li> </ul>	

4.5 Electromagnetic effects	
<p>4.5 (a) Electromagnetic induction</p> <p><b>Core</b></p> <ul style="list-style-type: none"> <li>Describe an experiment that shows that a changing magnetic field can induce an e.m.f. in a circuit</li> </ul>	<p><b>Supplement</b></p> <ul style="list-style-type: none"> <li>State the factors affecting the magnitude of an induced e.m.f.</li> <li>Show understanding that the direction of an induced e.m.f. opposes the change causing it</li> </ul>
<p>4.5 (b) a.c. generator</p> <p><b>Core</b></p> <ul style="list-style-type: none"> <li>Describe a rotating-coil generator and the use of slip rings</li> <li>Sketch a graph of voltage output against time for a simple a.c. generator</li> </ul>	
<p>4.5 (c) Transformer</p> <p><b>Core</b></p> <ul style="list-style-type: none"> <li>Describe the construction of a basic iron-cored transformer as used for voltage transformations</li> <li>Recall and use the equation <math>V_p/V_s = N_p/N_s</math></li> <li>Describe the use of the transformer in high-voltage transmission of electricity</li> <li>Give the advantages of high-voltage transmission</li> </ul>	<p><b>Supplement</b></p> <ul style="list-style-type: none"> <li>Describe the principle of operation of a transformer</li> <li>Recall and use the equation <math>V_p I_p = V_s I_s</math> (for 100% efficiency)</li> <li>Explain why energy losses in cables are lower when the voltage is high</li> </ul>
<p>4.5 (d) The magnetic effect of a current</p> <p><b>Core</b></p> <ul style="list-style-type: none"> <li>Describe the pattern of the magnetic field due to currents in straight wires and in solenoids</li> <li>Describe applications of the magnetic effect of current, including the action of a relay</li> </ul>	<p><b>Supplement</b></p> <ul style="list-style-type: none"> <li>State the qualitative variation of the strength of the magnetic field over salient parts of the pattern</li> <li>Describe the effect on the magnetic field of changing the magnitude and direction of the current</li> </ul>
<p>4.5 (e) Force on a current-carrying conductor</p> <p><b>Core</b></p> <ul style="list-style-type: none"> <li>Describe an experiment to show that a force acts on a current-carrying conductor in a magnetic field, including the effect of reversing: <ul style="list-style-type: none"> <li>the current</li> <li>the direction of the field</li> </ul> </li> </ul>	<p><b>Supplement</b></p> <ul style="list-style-type: none"> <li>Describe an experiment to show the corresponding force on beams of charged particles</li> <li>State and use the relative directions of force, field and current</li> </ul>

<p>4.5 (f) d.c. motor</p> <p><b>Core</b></p> <ul style="list-style-type: none"> <li>State that a current-carrying coil in a magnetic field experiences a turning effect and that the effect is increased by increasing the number of turns on the coil</li> <li>Relate this turning effect to the action of an electric motor</li> </ul>	<p><b>Supplement</b></p> <ul style="list-style-type: none"> <li>Describe the effect of increasing the current</li> </ul>
4.6 Cathode-ray oscilloscopes	
<p>4.6 (a) Cathode rays</p> <p><b>Core</b></p> <ul style="list-style-type: none"> <li>Describe the production and detection of cathode rays</li> <li>Describe their deflection in electric fields</li> <li>State that the particles emitted in thermionic emission are electrons</li> </ul>	
4.6 (b) Simple treatment of cathode-ray oscilloscope	<p><b>Supplement</b></p> <ul style="list-style-type: none"> <li>Describe (in outline) the basic structure and action of a cathode-ray oscilloscope (detailed circuits are <b>not</b> required)</li> <li>Use and describe the use of a cathode-ray oscilloscope to display waveforms</li> </ul>
<b>5. Atomic physics</b>	
5.1 Radioactivity	
<p>5.1 (a) Detection of radioactivity</p> <p><b>Core</b></p> <ul style="list-style-type: none"> <li>Show awareness of the existence of background radiation</li> <li>Describe the detection of <math>\alpha</math>-particles, <math>\beta</math>-particles and <math>\gamma</math>-rays (<math>\beta^+</math> are not included and <math>\beta</math>-particles will be taken to refer to <math>\beta^-</math>)</li> </ul>	
<p>5.1 (b) Characteristics of the three kinds of emission</p> <p><b>Core</b></p> <ul style="list-style-type: none"> <li>State that radioactive emissions occur randomly over space and time</li> <li>State, for radioactive emissions: <ul style="list-style-type: none"> <li>their nature</li> <li>their relative ionising effects</li> <li>their relative penetrating abilities</li> </ul> </li> </ul>	<ul style="list-style-type: none"> <li>Describe their deflection in electric fields and magnetic fields</li> <li>Interpret their relative ionising effects</li> </ul>



<p>5.1 (c) Radioactive decay</p> <p><b>Core</b></p> <ul style="list-style-type: none"> <li>State the meaning of radioactive decay, using equations (involving words or symbols) to represent changes in the composition of the nucleus when particles are emitted</li> </ul>	
<p>5.1 (d) Half-life</p> <p><b>Core</b></p> <ul style="list-style-type: none"> <li>Use the term <i>half-life</i> in simple calculations, which might involve information in tables or decay curves</li> </ul>	
<p>5.1 (e) Safety precautions</p> <p><b>Core</b></p> <ul style="list-style-type: none"> <li>Describe how radioactive materials are handled, used and stored in a safe way</li> </ul>	
<p>5.2 The nuclear atom</p>	
<p>5.2 (a) Atomic model</p> <p><b>Core</b></p> <ul style="list-style-type: none"> <li>Describe the structure of an atom in terms of a nucleus and electrons</li> </ul>	<p><b>Supplement</b></p> <ul style="list-style-type: none"> <li>Describe how the scattering of <math>\alpha</math>-particles by thin metal foils provides evidence for the nuclear atom</li> </ul>
<p>5.2 (b) Nucleus</p> <p><b>Core</b></p> <ul style="list-style-type: none"> <li>Describe the composition of the nucleus in terms of protons and neutrons</li> <li>Use the term <i>proton number, Z</i></li> <li>Use the term <i>nucleon number, A</i></li> </ul> <p>Use the term <i>nuclide</i> and use the nuclide notation <math>{}^A_ZX</math></p>	
<p>5.2 (c) Isotopes</p>	<p><b>Supplement</b></p> <ul style="list-style-type: none"> <li>Use the term <i>isotope</i></li> <li>Give and explain examples of practical applications of isotopes</li> </ul>

---

## 7. Practical assessment

---

Scientific subjects are, by their nature, experimental. So it is important that an assessment of a candidate's knowledge and understanding of physics should contain a practical component (see assessment objective C).

Schools' circumstances (e.g. the availability of resources) differ greatly, so three alternative ways of examining appropriate skills in assessment objective C are provided. The three alternatives are:

- Paper 4 – Coursework (school-based assessment)
- Paper 5 – Practical Test
- Paper 6 – Alternative to Practical (written paper).

Whichever practical assessment route is chosen, the following points should be noted:

- the same assessment objectives apply
- the same practical skills are to be learned and developed
- the same benefits to theoretical understanding come from all practical work
- the same motivational effect, enthusiasm and enjoyment should be experienced
- the same sequence of practical activities is appropriate.

### 7.1 Paper 4: Coursework

Teachers may not undertake school-based assessment without the written approval of Cambridge. This will only be given to teachers who satisfy Cambridge requirements concerning moderation and they will have to undergo special training in assessment before entering candidates.

Cambridge offers schools in-service training in the form of courses held at intervals in Cambridge and elsewhere, and also via the *Coursework Training Handbook*.

It is expected that the teaching and assessment of experimental skills and abilities will take place throughout the course.

The experimental skills and abilities to be assessed are:

- C1 Using and organising techniques, apparatus and materials
- C2 Observing, measuring and recording
- C3 Handling experimental observations and data
- C4 Planning and evaluating investigations

The four skills carry equal weighting.

All assessments must be based on experimental work carried out by the candidates.

Teachers must ensure that they can make available to Cambridge evidence of **two** assessments of each skill for each candidate. For skills C1 to C4 inclusive, information about the tasks set, and how the marks were awarded will be required. In addition, for skills C2, C3 and C4, the candidates' written work will also be required.

The assessment scores finally recorded for each skill must represent the candidate's best performances.

For candidates who miss the assessment of a given skill through no fault of their own, for example because of illness, and who cannot be assessed on another occasion, Cambridge procedure for special consideration should be followed. However, candidates who for no good reason absent themselves from an assessment of a given skill should be given a mark of zero for that assessment.

## Criteria for assessing experimental skills and abilities

Each skill must be assessed on a six-point scale, level 6 being the highest level of achievement. Each of the skills is defined in terms of three levels of achievement at scores of 2, 4 and 6.

A score of 0 should be awarded if there is no evidence of positive achievement for a skill.

For candidates who do not meet the criteria for a score of 2, a score of 1 is to be awarded if there is some evidence of positive achievement.

A score of 3 should be awarded for candidates who go beyond the level defined by 2, but who do not meet fully the criteria for 4.

Similarly, a score of 5 should be awarded for those who go beyond the level defined for 4, but do not meet fully the criteria for 6.

Score	Skill C1: Using and organising techniques, apparatus and materials
0	No evidence of positive achievement for this skill.
1	Some evidence of positive achievement, but the criteria for a score of 2 are not met.
2	Follows written, diagrammatic or oral instructions to perform a single practical operation. Uses familiar apparatus and materials adequately, needing reminders on points of safety.
3	Is beyond the level defined for 2, but does not meet fully the criteria for 4.
4	Follows written, diagrammatic or oral instructions to perform an experiment involving a series of step-by-step practical operations. Uses familiar apparatus, materials and techniques adequately and safely.
5	Is beyond the level defined for 4, but does not meet fully the criteria for 6.
6	Follows written, diagrammatic or oral instructions to perform an experiment involving a series of practical operations where there may be a need to modify or adjust one step in the light of the effect of a previous step. Uses familiar apparatus, materials and techniques safely, correctly and methodically.

Score	Skill C2: Observing, measuring and recording
0	No evidence of positive achievement for this skill.
1	Some evidence of positive achievement, but the criteria for a score of 2 are not met.
2	Makes observations or readings given detailed instructions. Records results in an appropriate manner given a detailed format.
3	Is beyond the level defined for 2, but does not meet fully the criteria for 4.
4	Makes relevant observations, measurements or estimates given an outline format or brief guidelines. Records results in an appropriate manner given an outline format.
5	Is beyond the level defined for 4, but does not meet fully the criteria for 6.
6	Makes relevant observations, measurements or estimates to a degree of accuracy appropriate to the instruments or techniques used. Records results in an appropriate manner given no format.

Score	Skill C3: Handling experimental observations and data
0	No evidence of positive achievement for this skill.
1	Some evidence of positive achievement, but the criteria for a score of 2 are not met.
2	Processes results in an appropriate manner given a detailed format. Draws an obvious qualitative conclusion from the results of an experiment.
3	Is beyond the level defined for 2, but does not meet fully the criteria for 4.
4	Processes results in an appropriate manner given an outline format. Recognises and comments on anomalous results. Draws qualitative conclusions which are consistent with obtained results and deduces patterns in data.
5	Is beyond the level defined for 4, but does not meet fully the criteria for 6.
6	Processes results in an appropriate manner given no format. Deals appropriately with anomalous or inconsistent results. Recognises and comments on possible sources of experimental error. Expresses conclusions as generalisations or patterns where appropriate.

Score	Skill C4: Planning, carrying out and evaluating investigations
0	No evidence of positive achievement for this skill.
1	Some evidence of positive achievement, but the criteria for a score of 2 are not met.
2	Suggests a simple experimental strategy to investigate a given practical problem. Attempts 'trial and error' modification in the light of the experimental work carried out.
3	Is beyond the level defined for 2, but does not meet fully the criteria for 4.
4	Specifies a sequence of activities to investigate a given practical problem. In a situation where there are two variables, recognises the need to keep one of them constant while the other is being changed. Comments critically on the original plan and implements appropriate changes in the light of the experimental work carried out.
5	Is beyond the level defined for 4, but does not meet fully the criteria for 6.
6	Analyses a practical problem systematically and produces a logical plan for an investigation. In a given situation, recognises there are a number of variables and attempts to control them. Evaluates chosen procedures, suggests/implements modifications where appropriate and shows a systematic approach in dealing with unexpected results.

## Guidance on candidate assessment

The following notes are intended to provide teachers with information to help them to make valid and reliable assessments of the skills and abilities of their candidates.

- The assessments should be based on the principle of positive achievement, i.e. candidates should be given opportunities to demonstrate what they understand and can do.
- It is expected that candidates will have had opportunities to acquire a given skill before assessment takes place.
- It is not expected that all of the practical work undertaken by a candidate will be assessed.
- Assessments can be carried out at any time during the course. However, at whatever stage assessments are done, the standards applied must be those expected at the end of the course, as exemplified in the criteria for the skills and abilities.
- Assessments should normally be made by the person responsible for teaching the candidates.
- A given practical task is unlikely to provide opportunities for all aspects of the criteria at a given level for a particular skill to be satisfied; for example, there may not be any anomalous results (C3). However, by using a range of practical work, teachers should ensure that opportunities are provided for all aspects of the criteria to be satisfied during the course.
- Extended experimental investigations are of great educational value. If such investigations are used for assessment purposes, teachers should make sure that the candidates have ample opportunity for displaying the skills and abilities required by the scheme of assessment.
- It is not necessary for all candidates within a teaching group, or within a Centre, to be assessed on exactly the same practical work, although teachers can use work that is undertaken by all of their candidates.
- When assessing group work, teachers must ensure that each candidate's individual contribution is assessed.
- Using and organising techniques, apparatus and materials might not generate a written product from the candidates (C1); it will often be assessed by watching the candidates carrying out practical work.

- Skills C2, C3 and C4 will usually generate a written product from the candidates; this will provide evidence for moderation.
- Raw scores for individual practical assessments should be recorded on the Individual Candidate Record Card. The final total score, which has been internally moderated should be recorded on the Coursework Assessment Summary Form (see Section 8.8).
- Raw scores for individual practical assessments may be given to candidates as part of the normal feedback from the teacher. The final, internally moderated, total score should **not** be given to the candidate.

## Moderation

### Internal moderation

When several teachers in a Centre are involved in internal assessment, arrangements must be made within the Centre for all candidates to be assessed to the same standard. It is essential that the marks for each skill assigned within different teaching groups (or classes) are moderated internally for the whole Centre entry. The Centre assessments will then be moderated externally by Cambridge.

### External moderation

Cambridge must receive internally moderated marks for all candidates by 30 April for the May/June examination and by 31 October for the November examination. See the *Cambridge Handbook* and the *Cambridge Administrative Guide* for more information on external moderation and on how to submit marks.

Once the marks have been received, Cambridge will select a sample of candidates whose work should be submitted for external moderation (a further sample may also be requested), and will ask the Centre to send immediately every piece of work that has contributed towards these candidates' final marks. Sciences Individual Candidate Record Cards and Sciences Coursework Assessment Summary Forms must also be sent with the coursework. All remaining coursework and records should be kept by the Centre until results are published.

Centres should use loose-leaf A4 file paper for practical written work. Original work is preferred for moderation, but authenticated photocopies can be sent if absolutely necessary.

Pieces of work for each skill should **not** be stapled together. Each piece of work should be clearly and securely labelled with:

- the skill being assessed
- the Centre number
- the candidate's name and candidate number
- the title of the experiment
- a copy of the mark scheme used
- the mark awarded.

Information about re-submission of coursework samples and about carrying forward internally assessed marks can be found in the *Cambridge Administrative Guide*.

## 7.2 Paper 5: Practical Test

This paper is designed to assess a candidate's competence in those practical skills which can realistically be assessed within the context of a formal test of limited duration. The best preparation for this paper is for candidates to pursue a fully integrated course in which practical work is a normal and natural part of the teaching.

Candidates may **not** use textbooks in the examination, nor any of their own records of laboratory work carried out during their course.

Candidates may be asked to carry out exercises involving:

- the measurement of physical quantities such as length or volume or force
- cooling and heating
- springs and balances
- timing motion or oscillations
- electric circuits
- optics equipment such as mirrors, prisms and lenses
- following specified procedures using simple apparatus, in situations where the method may not be familiar to the candidate.

Candidates may be required to do the following:

- select the most appropriate apparatus or method for the task and justify the choice made
- follow written instructions for the assembly and use of provided apparatus, for example when using ray-tracing equipment or connecting electrical circuits
- draw, complete and/or label diagrams of apparatus
- carry out the specified manipulation of the apparatus, for example:
  - when determining a derived quantity, such as the extension per unit load for a spring
  - when testing/identifying the relationship between two variables, such as between the p.d. across a wire and its length
  - when comparing physical quantities, such as two masses using a balancing method
- take readings from an appropriate measuring device (for example thermometer, rule, protractor, measuring cylinder, ammeter, stopwatch), including:
  - reading a scale with appropriate accuracy and precision
  - interpolating between scale divisions
  - correcting for zero errors, where appropriate
- take repeated measurements, where appropriate, to obtain an average value
- describe and/or explain precautions taken in carrying out a procedure, including the control of variables
- record their observations systematically, for example in a table, using appropriate units and a consistent and appropriate number of significant figures
- process their data as required, using a calculator where necessary
- present and analyse their data graphically, including interpolation and extrapolation, and the determination of a gradient, intercept or intersection
- draw an appropriate conclusion, justifying it by reference to their results
- comment critically on a procedure or point of practical detail and suggest an appropriate improvement
- plan an investigation including suggesting suitable apparatus and techniques.

### Apparatus list

This list below details the apparatus expected to be generally available for examination purposes. The list is not exhaustive: in particular, items that are commonly regarded as standard equipment in a physics laboratory are not included. The apparatus listed should be available for each candidate:

- ammeter FSD 1 A or 1.5 A
- voltmeter FSD 1 V, 5 V
- cells and holders to enable several cells to be joined
- connecting leads and crocodile clips
- d.c. power supply – variable to 12 V
- metre rule
- converging lens with a focal length  $f = 15$  cm
- low voltage filament bulbs in holders
- a supply of masses and holder
- newton meter
- plastic or polystyrene cup
- modelling clay (Plasticine)
- various resistors, including a variable resistor (rheostat)
- switch
- thermometer,  $-10^{\circ}\text{C}$  to  $+110^{\circ}\text{C}$  at  $1^{\circ}\text{C}$  graduations
- wooden board
- glass or perspex block, rectangular and semi-circular
- measuring cylinder,  $25\text{ cm}^3$ ,  $100\text{ cm}^3$
- beaker,  $250\text{ cm}^3$
- springs
- stopwatch
- ray box.

## 7.3 Paper 6: Alternative to Practical

This paper is designed to test candidates' familiarity with laboratory practical procedures. The questions contain many of the same elements as the questions on Paper 5. It is an alternative method of assessing candidates' understanding of experimental physics and therefore the best preparation for this paper is for candidates to pursue a fully integrated course in which practical work is a normal and natural part of the teaching.

Candidates may **not** use textbooks in the examination, nor any of their own records of laboratory work carried out during their course





## 8. Appendix

### 8.1 Electrical symbols

Candidates are expected to be able to recall and use the standard electrical symbols listed below.

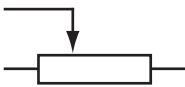
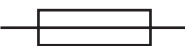
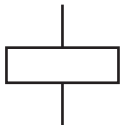
cell		diode	
battery of cells	 or 	light-emitting diode	
power supply		electric bell	
a.c. power supply		buzzer	
junction of conductors		microphone	
earth or ground		loudspeaker	
lamp		motor	
switch		generator	
fixed resistor		ammeter	
variable resistor		voltmeter	
thermistor		galvanometer	
light dependent resistor		transformer	
heater		AND gate	

potential divider	
fuse	
relay coil	
oscilloscope	

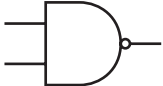
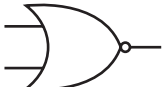
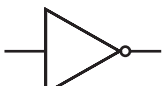
OR gate	
NAND gate	
NOR gate	
NOT gate	

## 8.2 Symbols, units and definitions of physical quantities

Candidates should be able to give the symbols for the following physical quantities and, where indicated, state the units in which they are measured. Candidates should be able to define the items indicated by an asterisk (\*). The list for the Extended syllabus content includes both the Core and the Supplement.

Candidates should be familiar with the following multipliers: M mega, k kilo, c centi, m milli:

Core			Supplement		
Quantity	Symbol	Unit	Quantity	Symbol	Unit
length	$l, h \dots$	km, m, cm, mm			
area	$A$	$m^2, cm^2$			
volume	$V$	$m^3, cm^3$			
weight	$W$	N			N*
mass	$m, M$	kg, g			mg
time	$t$	h, min, s			ms
density*		$g/cm^3, kg/m^3$			
speed*	$u, v$	km/h, m/s, cm/s			
acceleration	$a$		acceleration*		$m/s^2$
acceleration of free fall	$g$				
force	$F, P \dots$	N	force*		N*
			moment of a force*		N m
work done	$W, E$	J, kJ, MJ	work done by a force*		J*
energy	$E$	J, kJ, MJ			J*, kW h*
power	$P$	W, kW, MW	power*		W*
pressure	$p, P$		pressure*		Pa*, $N/m^2$
			atmospheric pressure		millibar, mm Hg

Core			Supplement		
Quantity	Symbol	Unit	Quantity	Symbol	Unit
temperature	$\theta, T$	$^{\circ}\text{C}$			
specific heat capacity	$c$	$\text{J}/(\text{g } ^{\circ}\text{C}), \text{J}/(\text{kg } ^{\circ}\text{C})$	specific heat capacity*		
latent heat	$L$	J	specific latent heat*	$l$	$\text{J}/\text{kg}, \text{J}/\text{g}$
			frequency*	$f$	Hz
			wavelength*	$\lambda$	m, cm
focal length	$f$				
angle of incidence	$i$	degree ( $^{\circ}$ )	refractive index	$n$	
angle of reflection, refraction	$r$	degree ( $^{\circ}$ )			
critical angle	$c$	degree ( $^{\circ}$ )			
potential difference/ voltage	$V$	V, mV	potential difference*		$\text{V}^*$
current	$I$	A, mA	current*		
			charge		C, A s
e.m.f.	$E$	V	e.m.f.*		
resistance	$R$	$\Omega$			

## 8.3 Safety in the laboratory

Responsibility for safety matters rests with Centres. Further information can be found in the following UK associations, websites, publications and regulations.

### Associations

CLEAPSS is an advisory service providing support in practical science and technology, primarily for UK schools. International schools and post-16 colleges can apply for associate membership which includes access to the CLEAPSS publications listed below.

**<http://www.cleapss.org.uk>**

### Websites

**<http://www.ncbe.reading.ac.uk/NCBE/SAFETY/menu.html>**

**<http://www.microbiologyonline.org.uk/teachers/safety-information>**

### Publications

*Safeguards in the School Laboratory*, ASE, 11th edition, 2006

*Topics in Safety*, ASE, 3rd edition, 2001

*CLEAPSS Laboratory Handbook*, updated 2009 (available to CLEAPSS members only)

*CLEAPSS Hazcards*, 2007 update of 1995 edition (available to CLEAPSS members only)

*Safety in Science Education*, DfES, HMSO, 1996

*Hazardous Chemicals Manual*, SSERC, 1997

*Hazardous Chemicals. An interactive manual for science education*, SSERC, 2002 (CD)

### UK Regulations

*Control of Substances Hazardous to Health Regulations (COSHH) 2002* and subsequent amendment in 2004

**<http://www.legislation.gov.uk/uksi/2002/2677/contents/made>,**

**<http://www.legislation.gov.uk/uksi/2004/3386/contents/made>**, a brief guide may be found at

**<http://www.hse.gov.uk/pubns/indg136.pdf>**

## 8.4 Glossary of terms used in science papers

This glossary will prove helpful to candidates as a guide, but it is neither exhaustive nor definitive. Candidates should appreciate that the meaning of a term must depend, in part, on its context.

1. *Define* (the term or terms...) is intended literally, only a formal statement or equivalent paraphrase being required.
2. *What do you understand by/What is meant by* (the term or terms...) normally implies that a definition should be given, together with some relevant comment on the significance or context of the term(s) concerned, especially where two or more terms are included in the question. The amount of supplementary comment intended should be interpreted in the light of the indicated mark value.
3. *State* implies a concise answer with little or no supporting argument (e.g. a numerical answer that can easily be obtained 'by inspection').
4. *List* requires a number of points, generally each of one word, with no elaboration. Where a given number of points is specified, this should not be exceeded.
5. *Explain* may imply reasoning or some reference to theory, depending on the context.
6. *Describe* requires the candidate to state in words (using diagrams where appropriate) the main points of the topic. It is often used to refer either to particular phenomena or to particular experiments. In the former instance, the term usually implies that the answer should refer to (visual) observations associated with the phenomena. In other contexts, *describe* should be interpreted more generally (i.e. the candidate has greater discretion about the nature and the organisation of the material to be included in the answer). *Describe and explain* may be coupled, as may *state and explain*.
7. *Discuss* requires the candidate to give a critical account of the points involved in the topic.
8. *Outline* implies brevity (i.e. restricting the answer to giving essentials).
9. *Predict* implies that the candidate is not expected to produce the required answer by recall but by making a logical connection between other pieces of information. Such information may be wholly given in the question or may depend on answers extracted in an earlier part of the question. *Predict* also implies a concise answer with no supporting statement required.
10. *Deduce* is used in similar way to *predict* except that some supporting statement is required e.g. reference to a law, a principle or the necessary reasoning should be included in the answer.
11. *Suggest* is used in two main contexts i.e. either to imply that there is no unique answer (e.g. in Physics there are several examples of energy resources from which electricity, or other useful forms of energy, may be obtained), or to imply that candidates are expected to apply their general knowledge to a 'novel' situation, one that may be formally 'not in the syllabus' – many data-response and problem-solving questions are of this type.
12. *Find* is a general term that may variously be interpreted as *calculate*, *measure*, *determine*, etc.
13. *Calculate* is used when a numerical answer is required. In general, working should be shown, especially where two or more steps are involved.
14. *Measure* implies that the quantity concerned can be directly obtained from a suitable measuring instrument e.g. length, using a rule, or mass, using a balance.
15. *Determine* often implies that the quantity in question cannot be measured directly but must be found by calculation, placing measured or known values of other quantities into a standard formula.
16. *Estimate* implies a reasoned order of magnitude statement or calculation of the quantity concerned, making such simplifying assumptions as may be necessary about points of principle and about the values of quantities not otherwise included in the question.
17. *Sketch* when applied to graph work, implies that the shape and/or position of the curve need only be qualitatively correct **but** candidates should be aware that, depending on the context, some quantitative aspects may be looked for, e.g. passing through the origin, having an intercept. In diagrams, *sketch* implies that simple, freehand drawing is acceptable; nevertheless, care should be taken over proportions and the clear exposition of important details.

## 8.5 Mathematical requirements

Candidates may use calculators in all parts of the exam.

Candidates should be able to:

- add, subtract, multiply and divide
- use averages, decimals, fractions, percentages, ratios and reciprocals
- use standard notation, including both positive and negative whole number indices
- recognise and use standard notation
- use direct and inverse proportion
- draw charts and graphs from given data
- interpret charts and graphs
- choose suitable scales and axes for graphs
- make approximate evaluations of numerical expressions
- recall and use equations for the area of a rectangle, triangle and circle and the volumes of a rectangular block and cylinder
- use usual mathematical instruments (ruler, compasses, protractor, set square)
- understand the meaning of angle, curve, circle, radius, diameter, square, parallelogram, rectangle and diagonal
- solve equations of the form  $x = y + z$  and  $x = yz$  for any one term when the other two are known
- recognise and use points of the compass (N, S, E, W)
- use sines and inverse sines (Supplement only).

## 8.6 ICT

In order to play a full part in modern society, candidates need to be confident and effective users of ICT. This syllabus provides candidates with a wide range of opportunities to use ICT in their study of Physics.

Opportunities for ICT include:

- gathering information from the internet, DVDs and CD-ROMs
- gathering data using sensors linked to data-loggers or directly to computers
- using spreadsheets and other software to process data
- using animations and simulations to visualise scientific ideas
- using software to present ideas and information on paper and on screen.

The examples listed in the table show some of the points in the syllabus where opportunities may be found.

ICT	Possible opportunities
Gathering information	Independent research into 1.6b, 3.2e, 4.5c, 4.6b, 5.1
Datalogging	Practical work associated with 1.2, 2.3
Processing data	Practical work associated with 3.2b, 4.3c, 5.1d
Visualisation	Demonstration of 1.2, 2.1b, 3.3, 4.5b, 4.5e
Making presentations	Practical work or independent research in 5.1a, 1.6b, 4.2a

## 8.7 Presentation of data

The solidus (/) is to be used for separating the quantity and the unit in tables, graphs and charts, e.g. time/s for time in seconds.

### (a) Tables

- Each column of a table will be headed with the physical quantity and the appropriate unit, e.g. time/s.
- The column headings of the table can then be directly transferred to the axes of a constructed graph.

### (b) Graphs

- The independent variable should be plotted on the x-axis (horizontal axis) and the dependent variable plotted on the y-axis (vertical axis).
- Each axis will be labelled with the physical quantity and the appropriate unit, e.g. time/s.
- The graph is the whole diagrammatic presentation. It may have one or several curves plotted on it.
- Curves and lines joining points on the graph should be referred to as 'curves'.
- Points on the curve should be clearly marked as crosses (x) or encircled dots (⊙). If a further curve is included, vertical crosses (+) may be used to mark the points.

### (c) Pie charts

- These should be drawn with the sectors in rank order, largest first, beginning at 'noon' and proceeding clockwise. Pie charts should preferably contain no more than six sectors.

### (d) Bar charts

- These are drawn when one of the variables is not numerical. They should be made up of narrow blocks of equal width that do **not** touch.

### (e) Histograms

- These are drawn when plotting frequency graphs with continuous data. The blocks should be drawn in order of increasing or decreasing magnitude and they **should** touch.

## 8.8 Forms

This section contains copies of the following forms, together with instructions on how to complete them:

- Experiment Form
- Individual Candidate Record Card
- Coursework Assessment Summary Form



**SCIENCES  
Experiment Form  
IGCSE**

**Please read the instructions printed overleaf.**

Centre Number						Centre Name	
Syllabus Code	<b>0</b>	<b>6</b>	<b>2</b>	<b>5</b>	Syllabus Title		<b>Physics</b>
Component Number	<b>0</b>	<b>4</b>			Component Title		<b>Coursework</b>
June/November	<b>2</b>	<b>0</b>	<b>1</b>	<b>5</b>			

Experiment Number	Experiment	Skill(s) Assessed

WMS634



PHYSICS/CW/EX/15

## Sciences experiment form – instructions

To complete the Sciences Experiment Form:

- 1 Enter the information required at the head of the form.
- 2 Use a separate form for each Syllabus.
- 3 Give a brief description of each of the experiments that your candidates performed for assessment in the Cambridge IGCSE Science Syllabus indicated. Use additional sheets as necessary.
- 4 Teachers must send to Cambridge copies of the experiment forms and the corresponding worksheets/ instructions and mark schemes for each assessed task sampled, for each of Skills AO3.1 to AO3.4.

**SCIENCES**

**Individual Candidate Record Card**

**IGCSE 2015**

**Please read the instructions printed overleaf and the General Coursework Regulations before completing this form.**

Centre number					Centre name		June/November	2	0	1	5
Candidate number					Candidate name		Teaching group/set				
Syllabus code	0	6	2	5	Syllabus title	<b>PHYSICS</b>	Component number	0	4	Component title	<b>COURSEWORK</b>

Date of Assessment	Experiment number from Sciences Experiment Form	Assess at least twice Ring highest two marks for each skill (Max 6 each assessment)				Relevant comments (for example, if help was given)
		C1	C2	C3	C4	
Marks to be transferred to						TOTAL
Coursework Assessment Summary Form		(max 12)	(max 12)	(max 12)	(max 12)	(max 48)

**WMS635**



**IGCSE/PHYSICS/CW/1/15**

## Individual candidate record card – instructions

**The Individual Candidate Record Card is only for use by teachers of candidates who have undertaken Coursework as part of the Cambridge IGCSE assessment.**

### Important:

When entering candidates from different teaching groups (for example, difference classes), the Centre must make sure that the marks for each skill are moderated internally. In practice, this means that all marks within a Centre must be brought to a common standard by the teacher responsible for co-ordinating internal assessment (i.e. the internal moderator). The aim is to produce a valid and reliable set of marks, which reflects the relative attainment of all Coursework candidates in the Centre. The outcome of internal moderation, in terms of the number of marks added to (or subtracted from) the candidate's initial total, must be clearly shown when these marks are transferred onto the Coursework Assessment Summary Form.

To complete the Individual Candidate Record Form:

- 1 Enter the information required at the head of the form.
- 2 After marking each item of Coursework (see Syllabus for more information), enter the marks awarded for each Assessment Objective, and the total marks awarded, into the appropriate boxes. Make sure that the addition of marks is independently checked.
- 3 Transfer the marks to the Coursework Assessment Summary Form – see this Form for further instructions, and see the note on internal moderation above.
- 4 Keep all Individual Candidate Record Cards, and Coursework, as these will be required for external moderation.

For more information at this stage please refer to the Syllabus booklet, and see the Coursework Assessment Summary Form. Further instructions on external moderation are in the *Cambridge Administrative Guide*.

**SCIENCES**  
**Coursework Assessment Summary Form**  
**IGCSE 2015**

**Please read the instructions printed overleaf and the General Coursework Regulations before completing this form.**

Centre number					Centre name	June/November	2	0	1	5	
Syllabus code	0	6	2	5	Syllabus title	<b>PHYSICS</b>	Component number	0	4	Component title	<b>COURSEWORK</b>

Candidate number	Candidate name	Teaching group/ set	C1 (max 12)	C2 (max 12)	C3 (max 12)	C4 (max 12)	Total mark (max 48)	Internally moderated mark (max 48)

Name of teacher completing this form		Signature		Date					
Name of internal moderator		Signature		Date					

## Coursework assessment summary form – instructions

- 1 Enter the information required at the head of the form.
- 2 List candidates so that their details can be easily transferred to the computer-printed Coursework mark sheet MS1, i.e. in candidate index number order. Show the teaching group or set for each candidate – this can be done using the teacher's initials.
- 3 Transfer each candidate's marks from their Individual Candidate Record Card as follows:
  - In the columns for individual skills or assignments, enter the marks awarded before internal moderation.
  - In the column headed 'Total Mark', enter the total mark awarded before internal moderation.
  - In the column headed 'Internally Moderated Mark', enter the total mark awarded *after* internal moderation took place.
- 4 The teacher completing the form, and the internal moderator/s, must check and sign the form where indicated.

---

## 9. Other information

---

### Equality and inclusion

Cambridge International Examinations has taken great care in the preparation of this syllabus and assessment materials to avoid bias of any kind. To comply with the UK Equality Act (2010), Cambridge has designed this qualification with the aim of avoiding direct and indirect discrimination.

The standard assessment arrangements may present unnecessary barriers for candidates with disabilities or learning difficulties. Arrangements can be put in place for these candidates to enable them to access the assessments and receive recognition of their attainment. Access arrangements will not be agreed if they give candidates an unfair advantage over others or if they compromise the standards being assessed.

Candidates who are unable to access the assessment of any component may be eligible to receive an award based on the parts of the assessment they have taken.

Information on access arrangements is found in the *Cambridge Handbook* which can be downloaded from the website **[www.cie.org.uk](http://www.cie.org.uk)**

### Language

This syllabus and the associated assessment materials are available in English only.

### Grading and reporting

Cambridge IGCSE results are shown by one of the grades A\*, A, B, C, D, E, F or G indicating the standard achieved, A\* being the highest and G the lowest. 'Ungraded' indicates that the candidate's performance fell short of the standard required for grade G. 'Ungraded' will be reported on the statement of results but not on the certificate. The letters Q (result pending); X (no results) and Y (to be issued) may also appear on the statement of results but not on the certificate.

### Entry codes

To maintain the security of our examinations we produce question papers for different areas of the world, known as 'administrative zones'. Where the component entry code has two digits, the first digit is the component number given in the syllabus. The second digit is the location code, specific to an administrative zone. Information about entry codes, examination timetables and administrative instructions can be found in the *Cambridge Guide to Making Entries*.

---

## 10. Additional information for England, Wales and Northern Ireland

---

This syllabus appears on the Register of Regulated Qualifications (<http://register.ofqual.gov.uk>) as a Cambridge International Level 1/Level 2 Certificate. In other contexts it is known as a Cambridge IGCSE.

Cambridge International Level 1/Level 2 Certificates are approved for regulation in England, Wales and Northern Ireland and are eligible for inclusion in school and college performance tables.

For up-to-date information on the performance tables, including the list of qualifications which count towards the English Baccalaureate, please go to the Department for Education website ([www.education.gov.uk/performance-tables](http://www.education.gov.uk/performance-tables)).

Candidates who are awarded grades D to G will have achieved an award at Level 1 of the National Qualifications Framework. Candidates who are awarded grades A\* to C will have achieved an award at Level 2 of the National Qualifications Framework.

### Prior learning

Candidates in England who are beginning this course should normally have followed the Key Stage 3 programme of study within the National Curriculum for England.

Other candidates beginning this course should have achieved an equivalent level of general education.

### Progression

Cambridge International Level 1/Level 2 Certificates are general qualifications that enable candidates to progress either directly to employment, or to proceed to further qualifications.

This syllabus provides a foundation for further study at levels 2 and 3 in the National Qualifications Framework, including GCSE, Cambridge International AS and A Level GCE, and Cambridge Pre-U qualifications.

Candidates who are awarded grades C to A\* are well prepared to follow courses leading to Level 3 AS and A Level GCE Physics, Cambridge Pre-U Physics, IB Certificates in Physics or the Cambridge International AS and A Level Physics.

### Grading and reporting

Cambridge International Level 1/Level 2 Certificate results are shown by one of the grades A\*, A, B, C, D, E, F or G indicating the standard achieved, A\* being the highest and G the lowest. 'Ungraded' indicates that the candidate's performance fell short of the standard required for grade G. 'Ungraded' will be reported on the statement of results but not on the certificate. The letters Q (result pending); X (no results) and Y (to be issued) may also appear on the statement of results but not on the certificate.



## Overlapping qualifications

Every qualification is assigned to a national classification code indicating the subject area to which it belongs. Candidates who enter for more than one qualification with the same classification code will only have one grade (the highest) counted for the purpose of the school and college performance tables. Centres may wish to advise candidates that, if they take two qualifications with the same classification code, colleges are very likely to take the view that they have achieved only one of the two qualifications. Candidates who have any doubts about their subject combinations should seek advice, either from their centre or the institution to which they wish to progress.

## Spiritual, moral, ethical, social, economic and cultural issues

### Spiritual

Candidates are encouraged to develop a sense of wonder at the simplicity and universality of physical laws and how these order and give meaning to our view of the ways that nature works. They have the opportunity to study physical systems from atomic systems to the solar system, helping them to develop an appreciation of the variety and immensity of the natural world.

### Moral and ethical

In the course of their practical work, candidates will gain an understanding of the scientific method and the importance of integrity in reporting results. They also have the opportunity to discuss how scientific developments in the modern world (for example, nuclear power, hydroelectric dams), often pose ethical as well as technological problems.

### Social and cultural

Through their practical work, candidates have the chance to develop their ability to work as a team, where appropriate, and to value others' ideas.

## Sustainable development, health and safety considerations, and international developments

### Environmental issues

Candidates have many opportunities to explore the role of applications of physics, for good or ill, in the community and environment. In particular, they study concerns about the containment and disposal of radioactive materials, and issues regarding energy conversion, conservation and resources.

### Health and safety issues

Candidates must follow good health and safety practice in the laboratory. They also learn about the hazards associated with electricity and gain an understanding of safety measures. Candidates must also understand the safety issues raised by working with radioactive materials and radiation.

### The international dimension

Throughout the course, candidates learn that the laws and language of physics are universal and transcend national and cultural boundaries. Teachers have the opportunity to discuss with their candidates how international collaboration in science is often needed to tackle global problems, such as issues surrounding global warming and radioactive waste disposal.

## Key Skills

This syllabus provides opportunities for learners to develop the following Key Skills at Level 1 and/or Level 2:

- Application of number
- Communication
- Information technology
- Improving own learning and performance
- Working with others
- Problem solving.

The extent to which this evidence fulfills the Key Skills criteria at these levels will be totally dependent on the style of teaching and learning. Further information on Key Skills can be found on the Ofqual website **[www.ofqual.gov.uk](http://www.ofqual.gov.uk)**

Cambridge International Examinations  
1 Hills Road, Cambridge, CB1 2EU, United Kingdom  
Tel: +44 (0)1223 553554 Fax: +44 (0)1223 553558  
Email: [info@cie.org.uk](mailto:info@cie.org.uk) [www.cie.org.uk](http://www.cie.org.uk)

® IGCSE is the registered trademark of Cambridge International Examinations.

© Cambridge International Examinations 2013

