

Core 1

A laboratory technician wants to make a resistor of value $64\ \Omega$, using some resistance wire. He takes $1.0\ \text{m}$ of this wire. The wire is shown in Fig. 1 as AC. He connects up the circuit shown.

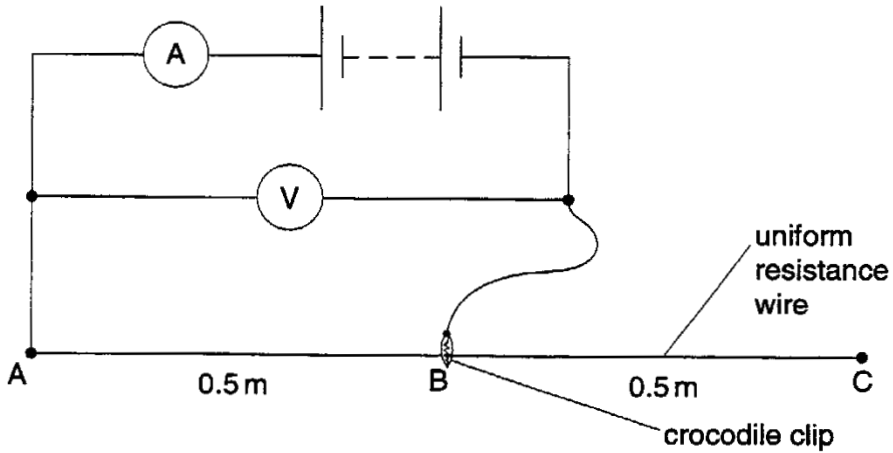

Fig. 1

- (a) He connects the crocodile clip at B, which is $0.5\ \text{m}$ from A. Here are the readings he gets.

voltmeter reading	12 V
ammeter reading	1.5 A

Calculate the resistance of wire AB.

ANSWER: resistance of AB = Ω [3]

- (b) The laboratory technician now connects the crocodile clip to C, to measure the resistance of $1\ \text{m}$ of the wire. The wire has constant thickness.

- (i) In the spaces below, write the readings he obtains. Ignore the effects of the resistance of the ammeter, voltmeter and battery.

voltmeter reading V
ammeter reading A

Core 1

(ii) What is the resistance of wire AC?

ANSWER: resistance of AC = Ω [3]

(c) Use your answer to (b) to answer the following questions.

(i) What is the resistance per metre of this wire?

ANSWER: resistance per metre = Ω/m

(ii) What length of wire does the laboratory technician need for the 64 Ω resistor?

ANSWER: length needed = m [3]

Core 2

- (a) On Fig 2 , sketch the graph you would expect to get if you plotted values of the potential difference V across a metallic conductor at constant temperature and the current I through it.

[2]



Fig 2

- (b) How would you use the graph to find the resistance of the conductor?

.....
.....
..... [1]

Alternative to Practical 1

Fig. 3 shows the top of a variable resistor that has a scale of resistance, which gives the resistance in use.

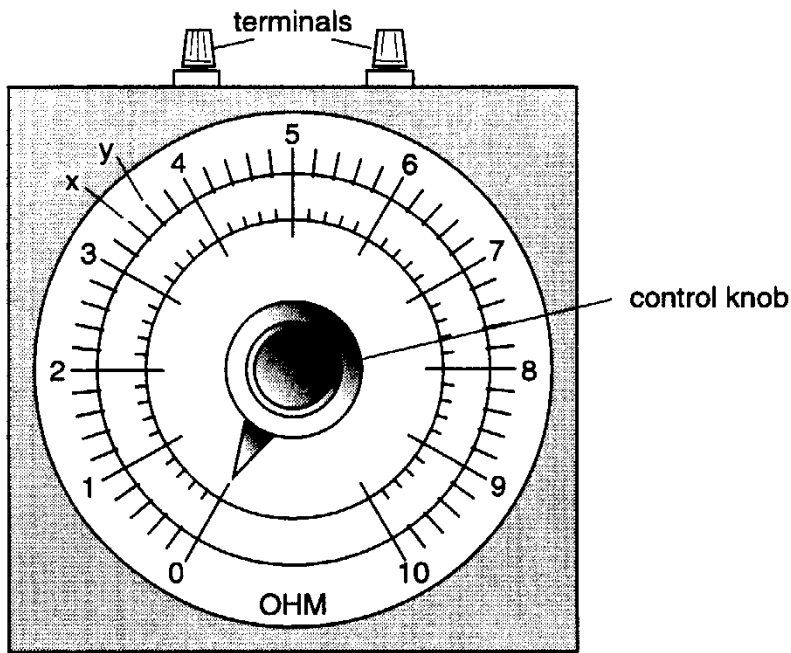

Fig. 3

(a) What range of values of resistance are available with this resistor?

range of values of resistance available = [1]

(b) On Fig 3, draw a line representing the position of the pointer when the value of the resistance in use is $6.3\ \Omega$. [1]

(c) Between the numbers 3 and 4, there are two letters x and y.

(i) What is the resistance when the pointer is at x?

resistance at x =

(ii) What is the *change* in resistance when the pointer moves from x to y?

change in resistance =

[2]

(d) Draw the circuit symbol for a variable resistor.

[1]

Alternative to Practical 1

- (e) A student is asked to connect a circuit so that the current through a filament lamp can be changed by using a variable resistor.

The student makes a mistake when connecting the circuit.

Fig. 4 represents the student's **wrongly** connected circuit. (In this diagram the circuit symbol is not used for the variable resistor.)

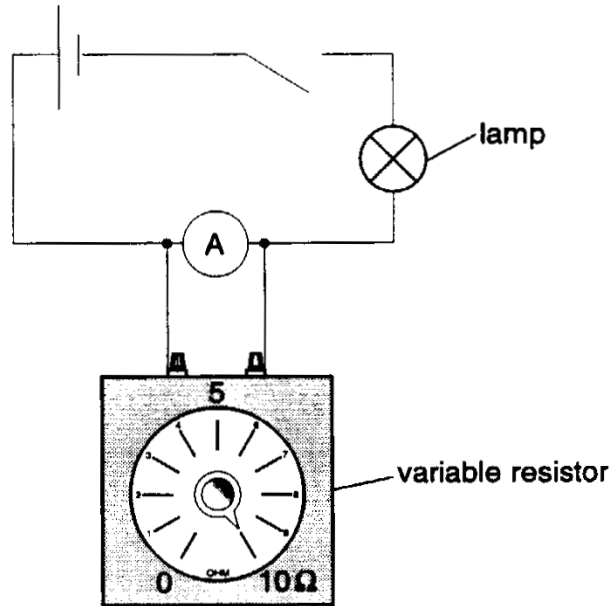

Fig 4

When the variable resistor is varied from $10\ \Omega$ to $5\ \Omega$, the **change** in the current is very small.

What could the student do to obtain a larger change in the current when the variable resistor is changed from $10\ \Omega$ to $5\ \Omega$?

.....

.....[1]

Alternative to Practical 2

The circuit shown in Fig. 5 was used to determine R , the resistance of a resistor, using the equation

$$R = \frac{V}{I}$$

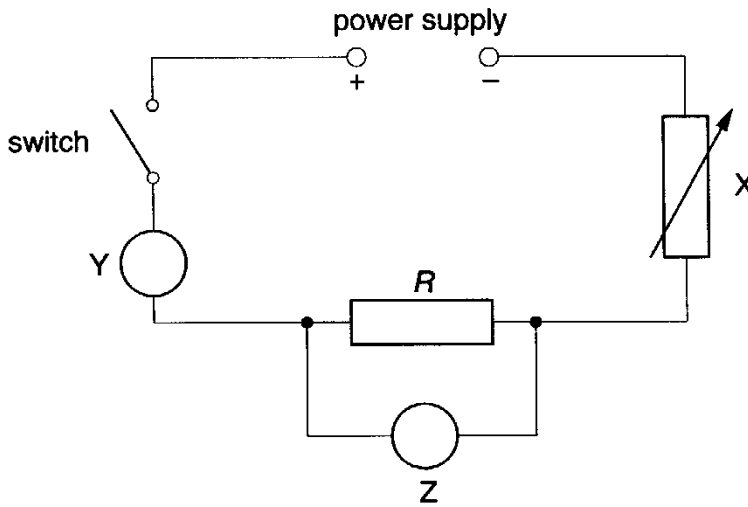

Fig. 5

The value for R is to be determined for different values of current I .

(a) Name the components labelled X and Y.

X

Y [2]

(b) What is the purpose of the component X?

.....
 [1]

(c) Explain how you would use the apparatus to determine values of R . Your answer should include what you would do before you close the switch.

.....

 [4]

(d) The value of R is about $9.5\ \Omega$ and the current through it must not exceed $0.10\ \text{A}$. What would be a good choice for the maximum reading of the component labelled Z?

maximum reading = [1]

Alternative to Practical 3

Fig. 6 is a series circuit in which a variable resistor is used so as to control the magnitude of the current in the circuit. The circuit is designed so as to obtain any value of current from 0.2 A to 2 A.

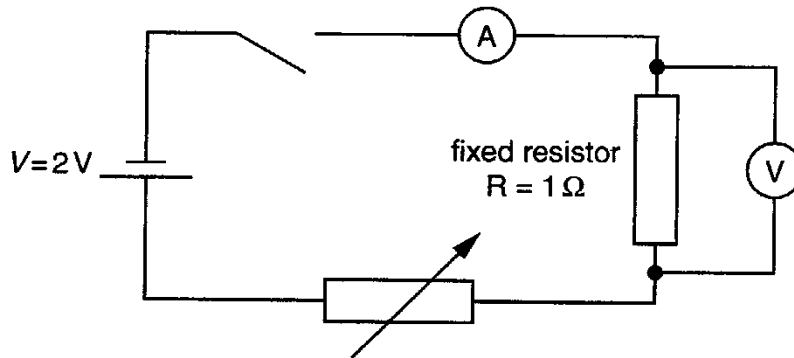

Fig 6

- (a) (i) The variable resistor is marked "0 to 10Ω ".
What is meant by the phrase "0 to 10Ω "?
.....[1]
- (ii) Why is it important that the value of the variable resistance may be changed smoothly?
.....[1]
- (b) (i) A 1 m length of nichrome wire has a resistance of 10.0Ω .
How would you use 1 m of this wire, and a jockey-slide contact, as the variable resistor shown in Fig. 6?
Your answer should
1. include a diagram showing the wire in use,
 2. explain how you would achieve smooth changes in the value of the variable resistance,
 3. explain why the wire must be bare and clean.

Diagram

Alternative to Practical 3

.....
.....
.....
.....
.....[3]

(ii) If the current in the nichrome wire becomes 2.0 A, then the wire becomes very hot and has a temperature of about 300 °C. The wire is then dangerous to touch.

A safe current to use in the circuit is about 0.6 A. To obtain a current of 0.6 A, the **total** resistance in the circuit should be about 3.3 Ω. The length of resistance wire in use is then 23 cm.

What could you do to the apparatus you have been given in (b)(i) to prevent anyone using a length of resistance wire that is less than 23 cm?

You may draw a diagram if you wish.

.....
.....
.....
.....[2]

Extension 1

Fig. 7 shows how a student set up a circuit using three identical lamps. Assume that the resistance of each lamp does not change with the brightness of the lamp.

Each lamp is labelled 12 V, 2.0 A.

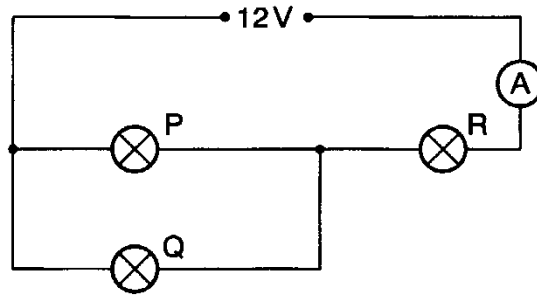

Fig. 7

(a) Calculate the resistance of one of the lamps.

resistance = [2]

(b) Calculate the combined resistance of the three lamps as connected in Fig. 7

combined resistance = [2]

(c) Calculate the current which would be shown on the ammeter in Fig. 7

current = [2]

(d) Explain why lamp R is less bright than normal and why lamps P and Q are both equally very dim.

.....

 [3]

Extension 1

- (e) In the space below draw a circuit diagram which shows P, Q and R connected so that they will all work at normal brightness.

[1]

Core 1

$$\begin{aligned} \text{a} \quad R &= V/I \\ &= 12/1.5 \\ &= 8 \Omega \end{aligned}$$

$$\begin{aligned} \text{b(i)} \quad &12 \text{ V} \\ &0.75 \text{ A} \end{aligned}$$

$$\text{(ii)} \quad 16 \Omega$$

$$\text{c(i)} \quad 16 \Omega/\text{m}$$

$$4 \text{ m}$$

Core 2

- a the graph should show a straight sloping line through the origin
- b calculate the resistance or $R = V/I$

Alternative to Practical 1

a 0 – 10 Ω

b a line drawn between 6.2 and 6.4

c(i) 3.4 Ω

0.2 Ω

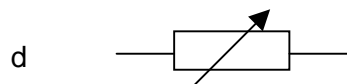

e connect a variable resistor in series

Alternative to Practical 2

- a X = variable resistor / rheostat
Y = ammeter
- b to change the value of the current
- c set X to maximum value, close switch
adjust X to obtain desired value of I
measure I and V
repeat settings for a check / zero meters
- d Full Scale Deflection 1 V (maximum V = $9.5 \times 0.1 = 0.95$ V)

Alternative to Practical 3

a(i) range of resistance
to obtain any value of current

b(i) 1



move the slider along the line
to ensure good electrical contact

insulate 23 cm
correct end clear

OR

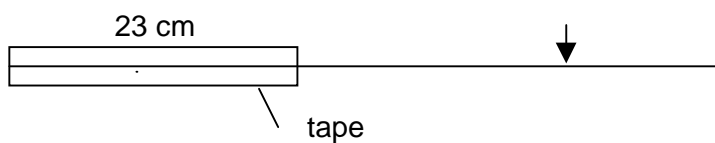

Extension 1

a $R = V/I$
 $= 6 \Omega$

b combined resistance of P and Q = 3Ω
whole circuit resistance = 9Ω

c $I = V/R$
 $= 1.3 \text{ A}$

d the voltage across R is less than 12 V / low / 8 V or the current through R is less than 2 A
the currents through P and Q are equal / voltage across P and Q is equal
the current through P and Q is less than through R or the potential difference across P and Q is less than across R

e the diagram should show P, Q and R in parallel