

Centre Number	Candidate Number	Name
---------------	------------------	------

UNIVERSITY OF CAMBRIDGE INTERNATIONAL EXAMINATIONS  
International General Certificate of Secondary Education

**PHYSICS**

**0625/06**

Paper 6 Alternative to Practical

October/November 2004

**1 hour**

Candidates answer on the Question Paper.  
No Additional Materials are required.

**READ THESE INSTRUCTIONS FIRST**

Write your Centre number, candidate number and name on all the work you hand in.  
Write in dark blue or black pen in the spaces provided on the Question Paper.  
You may use a soft pencil for any diagrams, graphs or rough working.  
Do not use staples, paper clips, highlighters, glue or correction fluid.

Answer **all** questions.  
At the end of the examination, fasten all your work securely together.  
The number of marks is given in brackets [ ] at the end of each question or part question.

For Examiner's Use	
1	
2	
3	
4	
5	
<b>Total</b>	

If you have been given a label, look at the details. If any details are incorrect or missing, please fill in your correct details in the space given at the top of this page.

Stick your personal label here, if provided.

This document consists of **12** printed pages.



- 1 The IGCSE class is investigating the rate of cooling of water in a beaker. Some of the apparatus used is shown in Fig. 1.1.

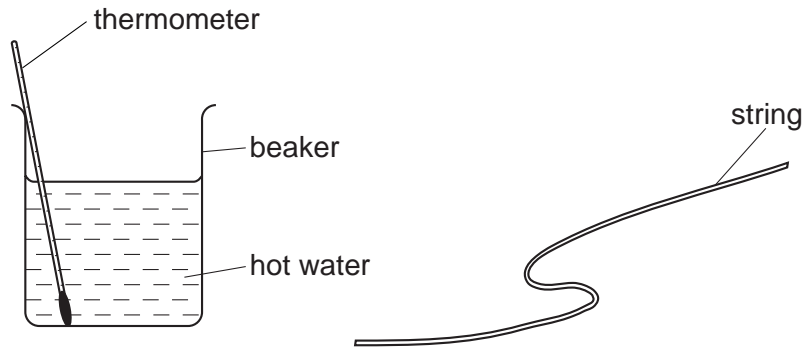

Fig. 1.1

During the experiment, a student measures the temperature of the water, its volume, the length of string wrapped round a beaker and the depth of water in the beaker.

- (a) Write down the readings shown in Figs. 1.2 and 1.3. Include appropriate units.

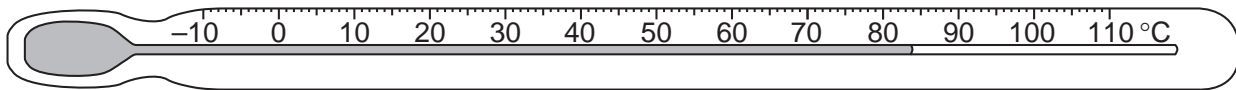

Fig. 1.2

temperature = .....

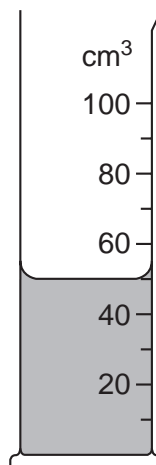
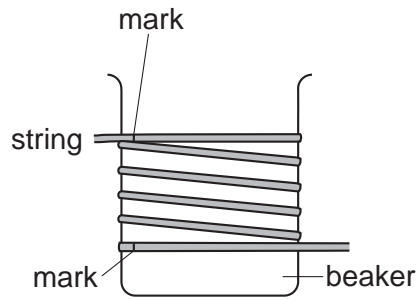

Fig. 1.3

volume of water in the measuring cylinder = .....

[3]

(b) The string is wrapped 5 times round the beaker and marked as shown in Fig. 1.4.



**Fig. 1.4**

The string is held against a metre rule as shown in Fig. 1.5.

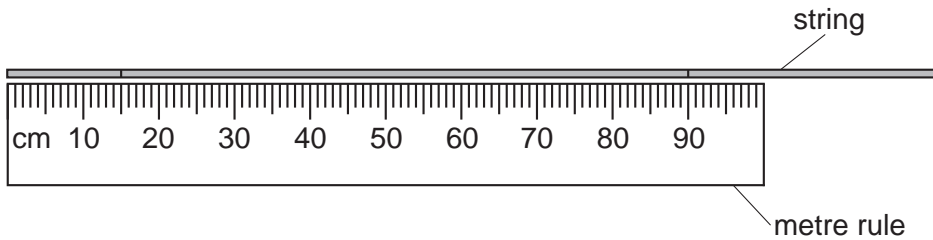

**Fig. 1.5**

(i) Write down the length of the string between the marks.

length = ..... cm

(ii) Calculate the circumference  $c$  of the beaker.

$c =$  ..... cm

(iii) Suggest one source of error in this method of determining the circumference.

.....  
 .....

(iv) Suggest one improvement to this method.

.....  
 .....

[4]

(c) A rule is placed beside the beaker, as shown in Fig. 1.6.

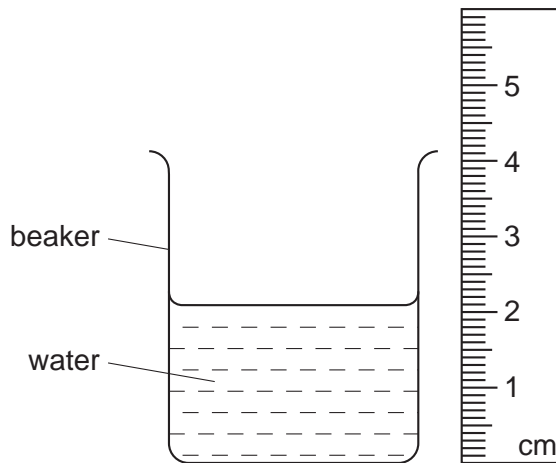

Fig. 1.6

(i) Write down the depth  $d$  of the water in the beaker.

$d = \dots\dots\dots$  cm

(ii) Calculate the surface area  $A$  of the curved surface of the beaker up to the water level using the equation  $A = dc$ .

$A = \dots\dots\dots$

[2]

(d) State the other measurements that need to be taken to determine the rate of cooling of the water.

.....  
 ..... [2]

- 2 A student carries out an experiment to determine the density of plasticine. She records the mass  $m$  and the volume  $V$  of a range of differently-sized samples. These readings are plotted on a graph as shown in Fig. 2.1.

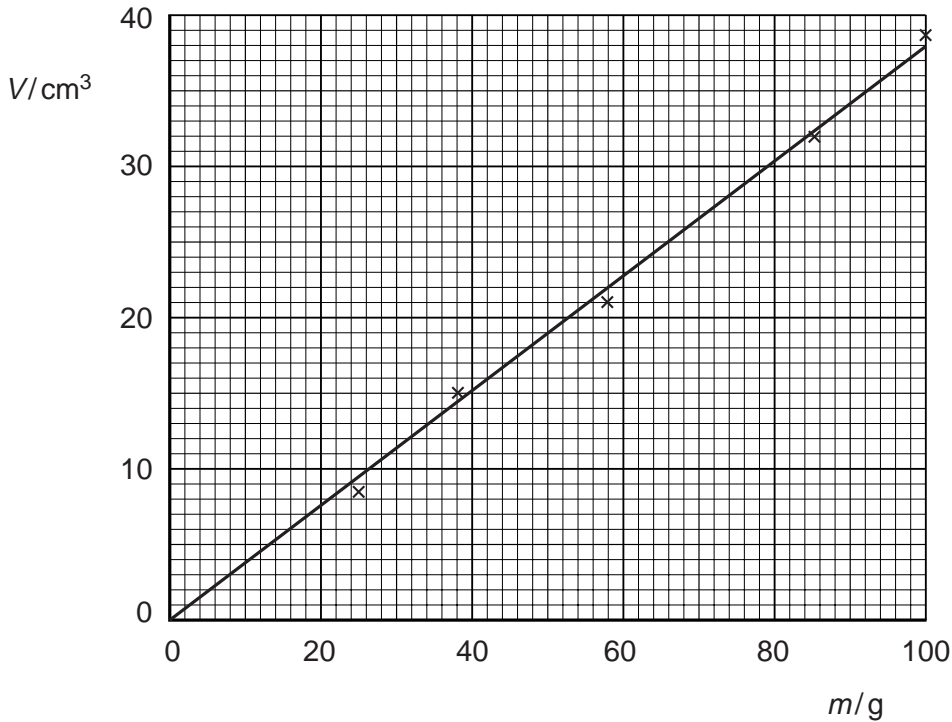

Fig. 2.1

- (a) (i) Determine the gradient  $G$  of the line. Show clearly how you obtain the necessary information.

$G = \dots\dots\dots$

- (ii) Determine the density  $\rho$  of the plasticine using the equation  $\rho = \frac{1}{G}$ .

$\rho = \dots\dots\dots$

[5]

- (b) The student could calculate the density from one set of readings. Suggest why she takes more than one set of readings and plots a graph.

.....  
..... [1]

- 3 A student carries out an experiment using a simple pendulum. Fig. 3.1 shows the apparatus.

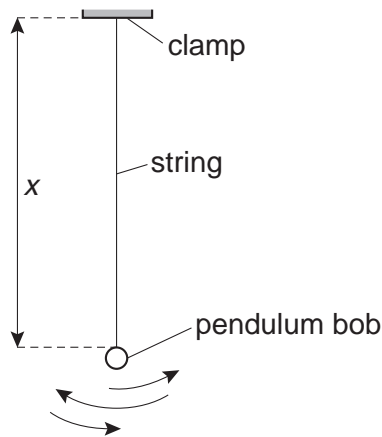

**Fig. 3.1**

The student records the time  $t$  taken for 20 complete oscillations for a range of different lengths  $x$  of the string. The readings are shown in the table.

$x/\text{cm}$	$l/\text{cm}$	$t/\text{s}$	$T/\text{s}$
90.0		38.5	
80.0		36.0	
70.0		33.4	
60.0		31.4	
50.0		28.2	
40.0		25.5	

The length  $l$  of the pendulum is given by the equation  $l = x + r$ , where  $r$  is the radius of the pendulum bob.

Fig. 3.2 shows the pendulum bob drawn actual size.

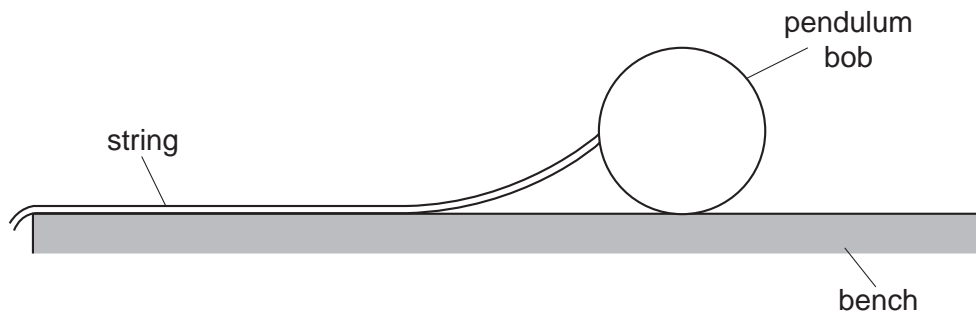

**Fig. 3.2**

- (a) (i) Use your rule to measure the diameter  $d$  of the pendulum bob.

$d = \dots\dots\dots$

- (ii) Calculate the radius  $r$  of the pendulum bob.

$r = \dots\dots\dots$

[2]

- (b) (i) Complete the column for the length  $l$ /cm in the table using the equation  $l = x + r$ .

- (ii) The period  $T$  is the time taken for one complete oscillation. Complete the column for the period  $T$ /s in the table.

[3]

- (c) Plot the graph of  $T$ /s ( $y$ -axis) against  $l$ /cm ( $x$ -axis). Start the  $T$ /s axis at  $T = 1.0$  s.

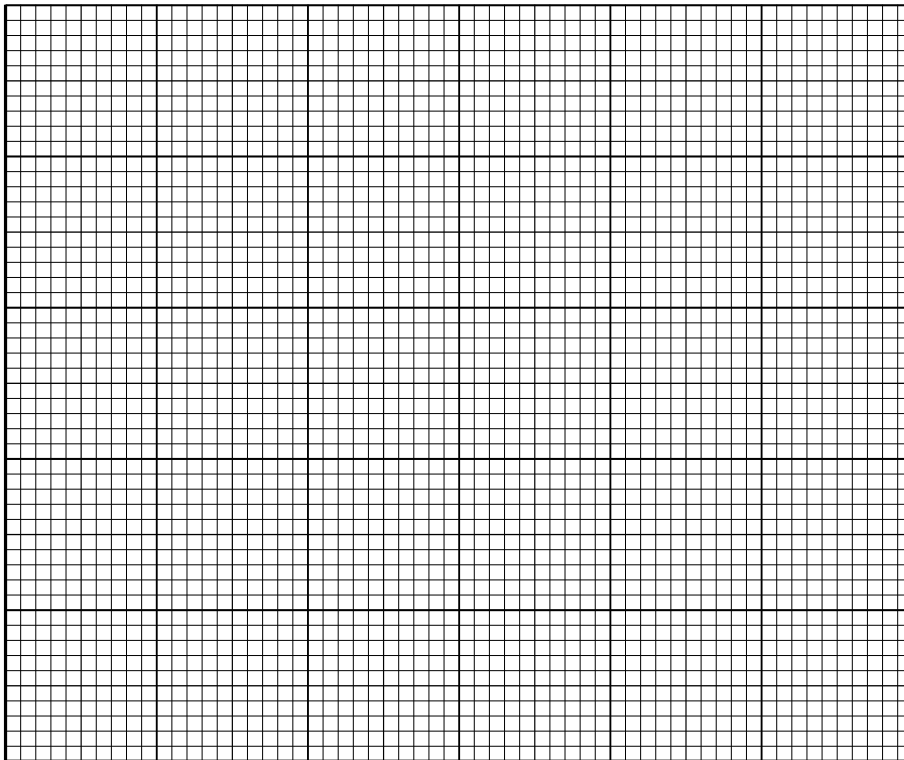

[5]

- (d) Using the graph, find the length  $l_a$  of the pendulum that would have a period of 1.50 s.

$l_a = \dots\dots\dots$  cm

[1]

- 4 A student is investigating the passage of light through a transparent block, as shown in Fig. 4.1.

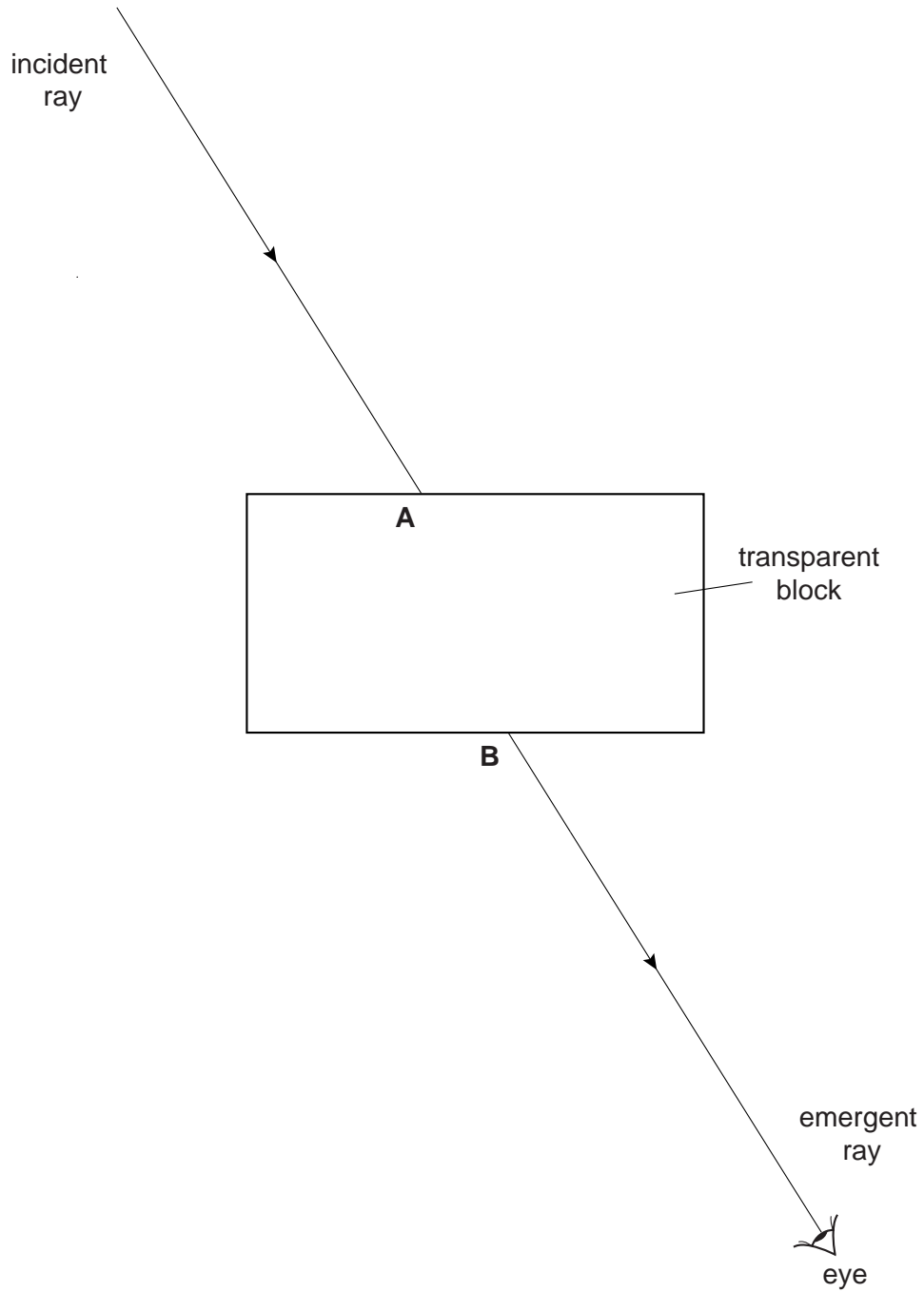

Fig. 4.1



The student looks through the block. He places pins so that two pins marking the incident ray and two pins marking the emergent ray all appear to be exactly one behind the other.

(a) On Fig. 4.1, mark suitable positions for the four pins, two on the incident ray and two on the emergent ray. [1]

(b) (i) On Fig. 4.1, draw the normal at point **A**.

(ii) On Fig. 4.1, draw in the line **AB**. Measure and record the angle of refraction  $r$  between the line **AB** and the normal.

$r = \dots\dots\dots$

(iii) Measure and record the angle of incidence  $i$  between the incident ray and the normal.

$i = \dots\dots\dots$

[4]

- 5 The IGCSE class is carrying out investigations of the resistance of bare resistance wires. Fig. 5.1 shows the circuit used.

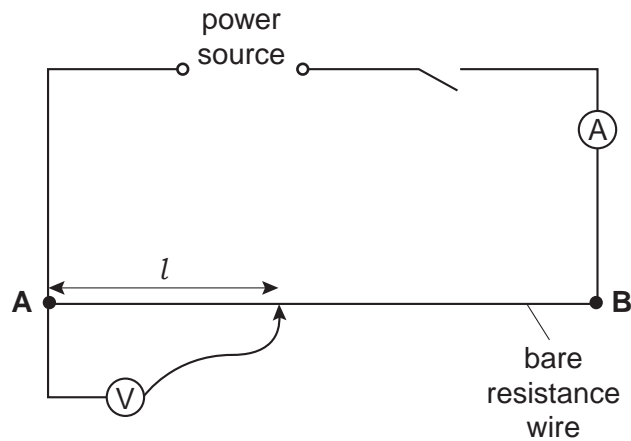

Fig. 5.1

The students record the current  $I$  in the circuit and then record the p.d.  $V$  across different lengths  $l$  of the bare resistance wire. The length of wire from **A** to **B** is 100.0 cm. The readings obtained by one student are shown in the table.

$$I = 0.84 \text{ A}$$

$V/$	$l/$	$R/$
0.39	20.0	
0.82	40.0	
1.22	60.0	
1.58	80.0	
1.89	100.0	

- (a) (i) Calculate the resistance of each length  $l$  of wire using the equation  $R = \frac{V}{I}$ . Write the resistance values in the table.
- (ii) Complete the column headings in the table.

[3]

- (b) In a second experiment, the students use wires of the same material but with different diameters  $d$ . The p.d. is measured across the same length of wire each time. Fig. 5.2 shows the circuit used.

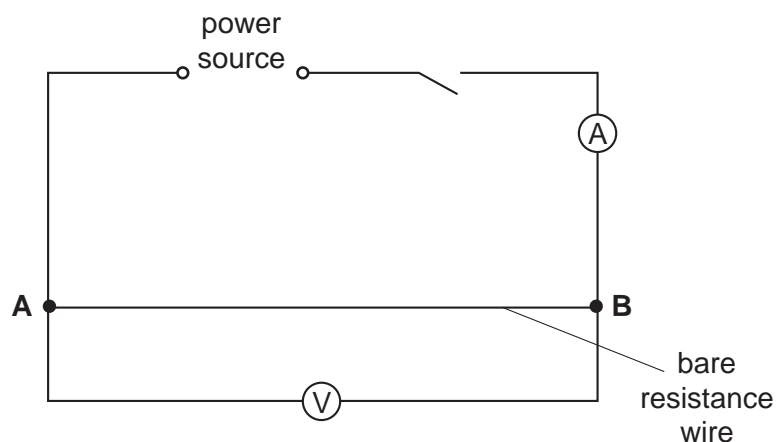

Fig. 5.2

These are the readings correctly obtained by one student.

Wire 1	$I = 0.1 \text{ A}$	Wire 2	$I = 0.4 \text{ A}$
	$V = 1.8 \text{ V}$		$V = 1.8 \text{ V}$
	$d = 0.24 \text{ mm}$		$d = 0.48 \text{ mm}$

- (i) Calculate the resistance  $R$  of each wire, using the equation  $R = \frac{V}{I}$ .

wire 1,  $R =$  .....

wire 2,  $R =$  ..... [1]

- (ii) Based on the results for the two wires, which of the following statements is a correct conclusion? Tick one box.

A wire with half the diameter has half the resistance.

A wire with half the diameter has twice the resistance.

A wire with half the diameter has one quarter the resistance.

A wire with half the diameter has four times the resistance.

[1]

- (iii) Using your answers to (i) and (ii), calculate the expected resistance of a wire **AB** of the same material if it has a diameter of 0.12 mm.

expected resistance = ..... [1]

- (c) What instrument would you use to measure the diameter of the wires as accurately as possible?

..... [1]

---

*Copyright Acknowledgements*

Every reasonable effort has been made to trace all copyright holders where the publishers (i.e. UCLES) are aware that third-party material has been reproduced. The publishers would be pleased to hear from anyone whose rights we have unwittingly infringed.

University of Cambridge International Examinations is part of the University of Cambridge Local Examinations Syndicate (UCLES), which is itself a department of the University of Cambridge.