



UNIVERSITY OF CAMBRIDGE INTERNATIONAL EXAMINATIONS  
International General Certificate of Secondary Education

CANDIDATE  
NAME

CENTRE  
NUMBER

--	--	--	--	--

CANDIDATE  
NUMBER

--	--	--	--



**PHYSICS**

**0625/53**

Paper 5 Practical Test

**May/June 2013**

**1 hour 15 minutes**

Candidates answer on the Question Paper.

Additional Materials: As listed in the Confidential Instructions.

**READ THESE INSTRUCTIONS FIRST**

Write your Centre number, candidate number and name in the spaces at the top of the page.

Write in dark blue or black pen.

You may use a pencil for any diagrams, graphs or rough working.

Do not use staples, paper clips, highlighters, glue or correction fluid.

**DO NOT WRITE IN ANY BARCODES.**

Answer **all** questions.

Electronic calculators may be used.

You may lose marks if you do not show your working or if you do not use appropriate units.

At the end of the examination, fasten all your work securely together.

The number of marks is given in brackets [ ] at the end of each question or part question.

For Examiner's Use	
1	
2	
3	
4	
<b>Total</b>	

This document consists of **12** printed pages.



- 1 In this experiment, you will determine the magnification produced by a converging lens.

Carry out the following instructions, referring to Fig. 1.1.

The distance  $u$  between the illuminated triangle and the lens has been set for you.

**Do not** change this distance.

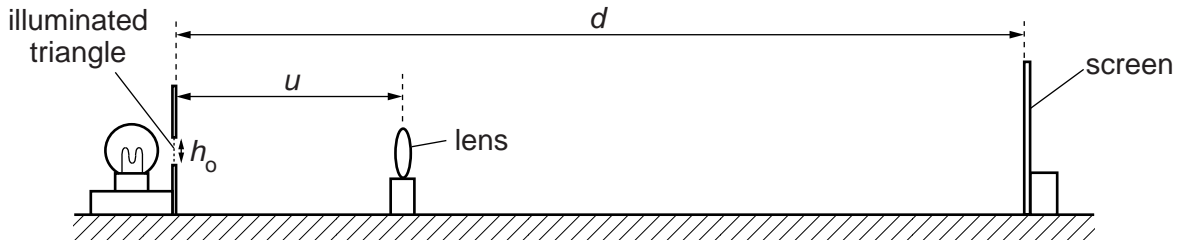

Fig. 1.1

- (a) (i) Carefully measure  $u$  and record the value.

$u =$  .....

- (ii) Place the screen near the lens. Move the screen away from the lens until a sharp image of the triangle is seen on the screen.
- (iii) Carefully measure  $d$ , the distance between the illuminated triangle and the screen, and record the value.

$d =$  .....

- (iv) Calculate a value  $m$  for the magnification, using your answers to (a)(i) and (a)(iii), and the equation  $m = \frac{d-u}{u}$ .

$m =$  .....

[2]

- (b) (i) Measure  $h_o$ , the height of the illuminated triangle, and record the value.

$h_o =$  .....

- (ii) Measure  $h_i$ , the height of the sharp image on the screen, and record the value.

$h_i =$  .....

- (iii) Calculate  $M$ , another value for the magnification, using your answers to (b)(i) and (b)(ii), and the equation  $M = \frac{h_i}{h_o}$ .

$M =$  .....

[2]

(c) A student says that the values of  $m$  and  $M$  should be the same.

State whether or not your findings support this. Justify your answer by reference to your results for  $m$  and  $M$ .

statement .....

.....

justification .....

.....

.....

[2]

(d) (i) In the space below, sketch the sharp image seen on the screen.

(ii) Describe one difficulty you might have found when measuring the height of this image.

.....

.....

.....

[2]

(e) State two precautions which you took to make the experiment reliable.

1. ....

.....

2. ....

.....

[2]

[Total: 10]

2 In this experiment, you will investigate how water cools.

The thermometers have been set up in the clamps for you. **Do not** adjust the heights of the thermometers.

Carry out the following instructions, referring to Fig. 2.1.

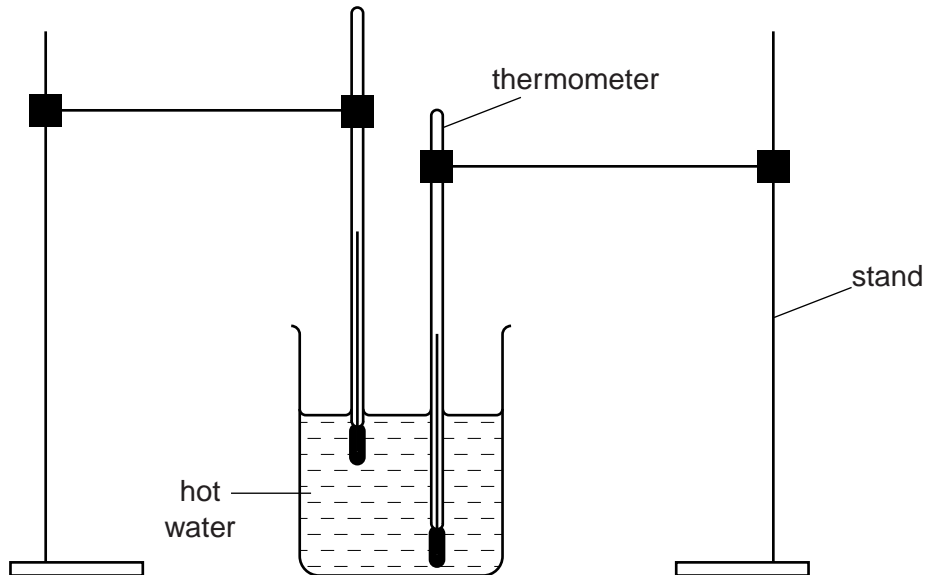

Fig. 2.1

- (a) (i) Pour hot water into the beaker until it just covers the bulb of the upper thermometer. Do not stir the water for the rest of the experiment.
- (ii) Wait for about 30 seconds before taking any measurements.
- (iii) Start the stopclock and read both thermometers. In the top row of Table 2.1, record these temperatures.
- (iv) Record in the table the temperature  $\theta$  of each thermometer at 1 minute intervals until time  $t = 6$  minutes.
- (v) Complete the column headings in the table.

Table 2.1

	thermometer bulb near the bottom of the beaker	thermometer bulb near the surface of the water
$t/\text{min}$	$\theta/$	$\theta/$
0		
1		
2		
3		
4		
5		
6		

[4]

**(b)** State in which position of the thermometer bulb the average rate of cooling is the greater. Justify your answer by referring to your results.

position .....

justification .....

.....

.....

[2]

**(c)** What precaution do your results suggest should be taken when measuring the temperatures of liquids?

Explain how your results show that this is a sensible precaution.

precaution .....

.....

explanation .....

.....

.....

[2]

**(d)** Another IGCSE student wants to repeat your experiment in order to check the results.

Suggest two experimental conditions which should be kept the same.

1. ....

.....

2. ....

.....

[2]

[Total: 10]

- 3 In this experiment, you will investigate the resistance of electric circuits with lamps connected in different combinations.

The apparatus has been set up for you as shown in Fig. 3.1.

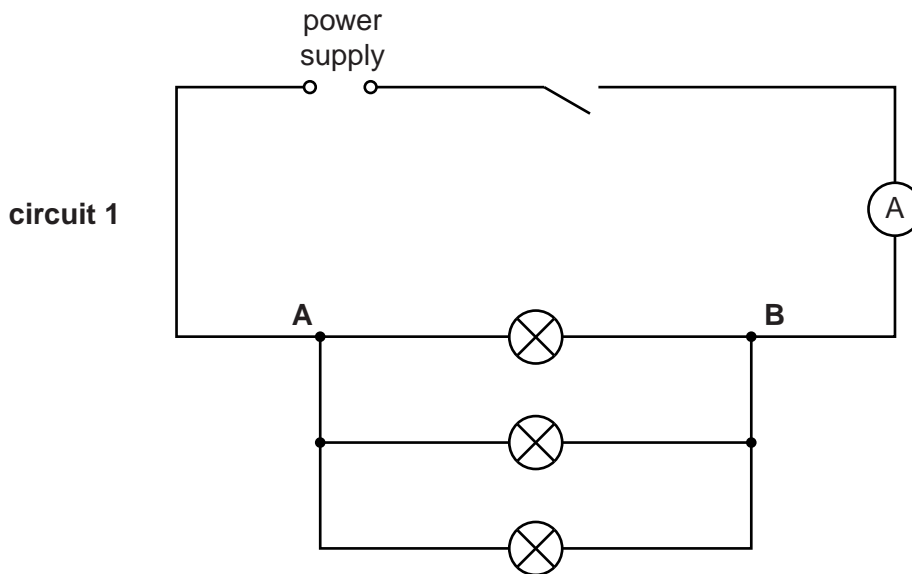

Fig. 3.1

- (a) On Fig. 3.1, draw the symbol for a voltmeter, connected to measure the potential difference between **A** and **B**. [1]
- (b) (i) Connect your voltmeter to the apparatus to measure the potential difference  $V$  between **A** and **B**.
- (ii) Switch on. Measure, and record in Table 3.1, the potential difference  $V$  and the current  $I$  shown by the ammeter. Switch off.

Table 3.1

circuit	$V/$	$I/$	$R/$
1			
2			
3			

[5]

- (c) (i) Reconnect the lamps between **A** and **B** as shown in Fig. 3.2.  
 (ii) Repeat steps (b)(i) and (b)(ii) for circuit 2.

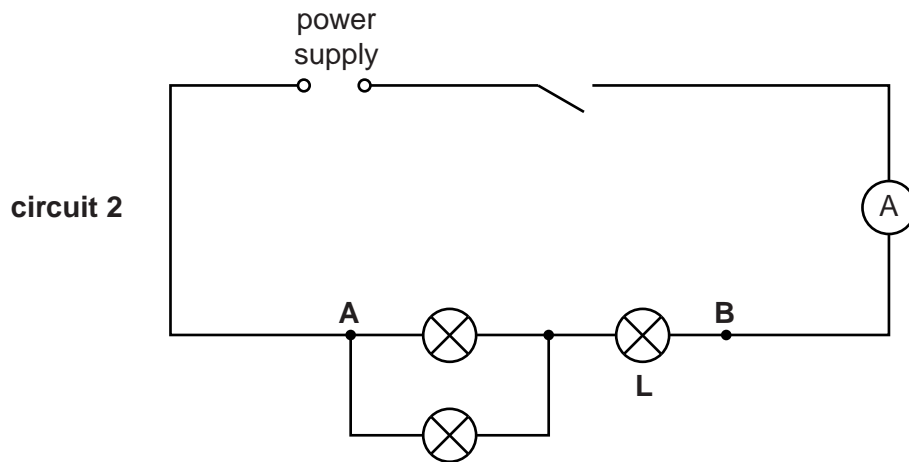

Fig. 3.2

- (d) (i) Reconnect the lamps between **A** and **B** as shown in Fig. 3.3.  
 (ii) Repeat steps (b)(i) and (b)(ii) for circuit 3.

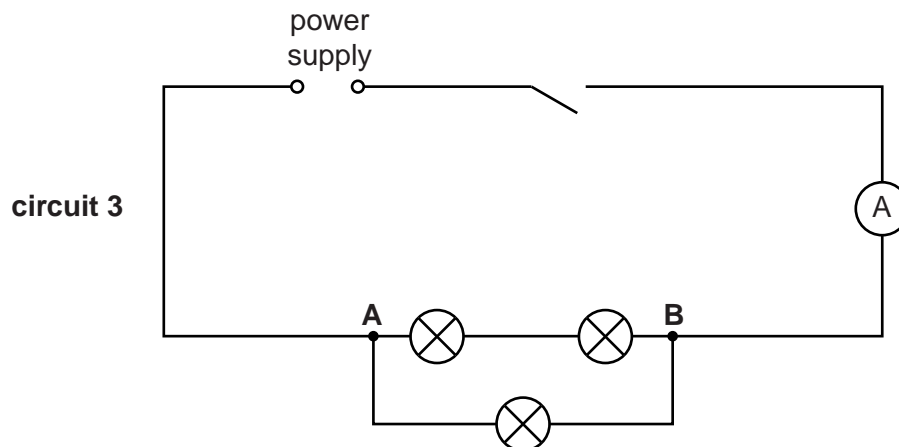

Fig. 3.3

- (e) Calculate, and record in the table, the total resistance  $R$  of each combination of the lamps, using the equation  $R = \frac{V}{I}$ .  
 (f) Complete the column headings in the table.

**Question 3 continues on the next page.**

- (g) If each of the lamps has the same resistance, the total resistance of the lamps in circuit 3 should be twice the total resistance of the lamps in circuit 1.

State whether your findings show this to be the case. Justify your answer by reference to your results.

statement .....

.....

justification .....

.....

.....

[2]

- (h) The resistance of a lamp is significantly affected by the temperature of its filament.

Explain whether this might have affected the results of the experiment.

.....

.....

..... [1]

- (i) An IGCSE student wants to measure the potential difference across the lamp marked **L** in circuit 2.

On the diagram for **circuit 2, Fig. 3.2**, show how a voltmeter should be connected to measure this potential difference. [1]

[Total: 10]



**Turn over for Question 4**

4 In this experiment, you will investigate the oscillations of a pendulum.

(a) Carry out the following instructions, referring to Figs. 4.1 and 4.2. The pendulum has already been set up for you.

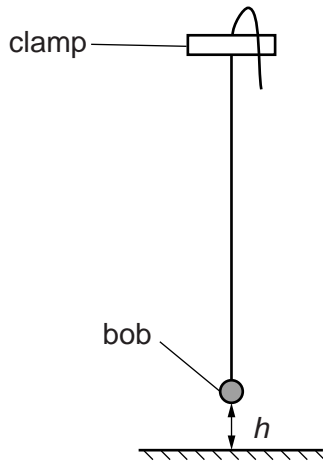

Fig. 4.1

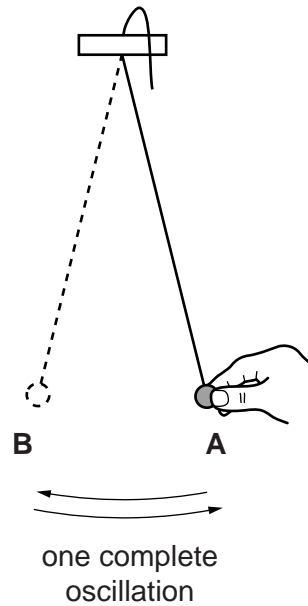

Fig. 4.2

- (i) Measure, and record in the first row of Table 4.1, the height  $h$  of the pendulum bob above the bench.
- (ii) Pull the pendulum bob a small distance to one side, as shown in Fig. 4.2, and release it.

It will oscillate backwards and forwards between **A** and **B**, as shown in Fig. 4.2. One complete oscillation is from **A** to **B** and back to **A**.

Measure the time  $t$  for 10 complete oscillations. Record this value in the table.

Table 4.1

$h/\text{cm}$	$t/\text{s}$	$T/\text{s}$	$T^2/\text{s}^2$

- (iii) Without changing the height of the clamp, adjust the string to shorten the pendulum by approximately 10 cm.  
Repeat steps (a)(i) and (a)(ii).
- (iv) Repeat step (a)(iii) to obtain 3 more sets of readings.

[2]

(b) (i) For each value of height  $h$ , calculate the time  $T$  for one complete oscillation using the equation  $T = \frac{t}{10}$ .

Record these values in the table.

(ii) Calculate the values of  $T^2$  and record these in the table. [1]

(c) Plot a graph of  $T^2/s^2$  ( $y$ -axis) against  $h/cm$  ( $x$ -axis).

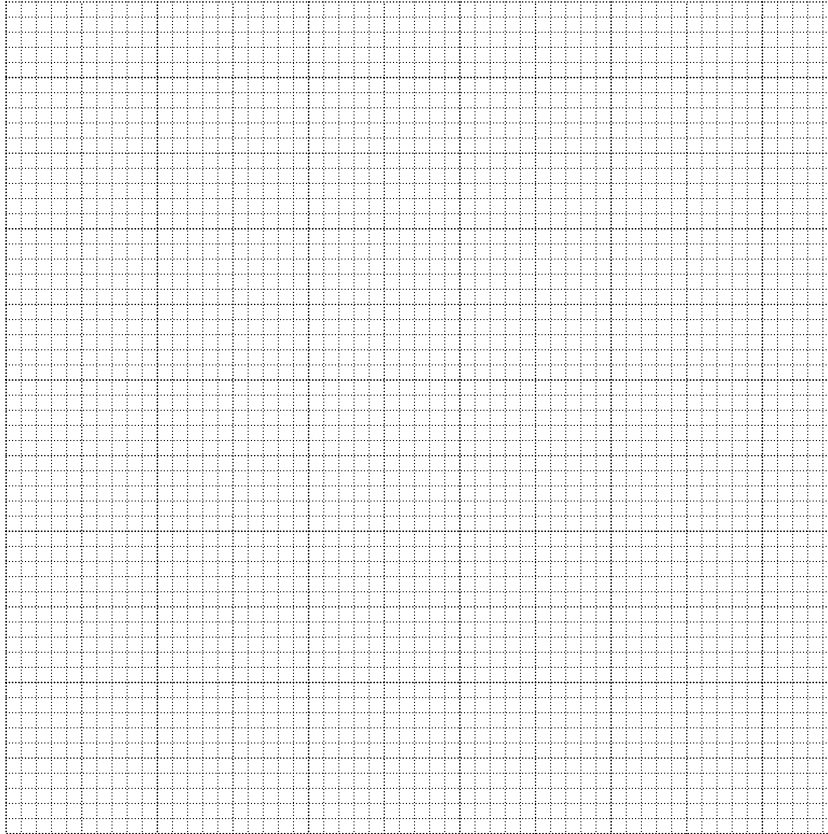

[4]

(d) Determine the gradient  $G$  of the graph.

Show clearly on the graph how you obtained the necessary information.

$G = \dots\dots\dots$  [2]

(e) Describe a precaution you took in order to measure  $h$  as accurately as possible. You may draw a diagram.

For  
Examiner's  
Use

.....  
.....  
..... [1]

[Total: 10]

Permission to reproduce items where third-party owned material protected by copyright is included has been sought and cleared where possible. Every reasonable effort has been made by the publisher (UCLES) to trace copyright holders, but if any items requiring clearance have unwittingly been included, the publisher will be pleased to make amends at the earliest possible opportunity.

University of Cambridge International Examinations is part of the Cambridge Assessment Group. Cambridge Assessment is the brand name of University of Cambridge Local Examinations Syndicate (UCLES), which is itself a department of the University of Cambridge.