



UNIVERSITY OF CAMBRIDGE INTERNATIONAL EXAMINATIONS  
International General Certificate of Secondary Education

CANDIDATE  
NAME

CENTRE  
NUMBER

--	--	--	--	--

CANDIDATE  
NUMBER

--	--	--	--

\* 8 5 1 1 2 7 2 9 5 1 \*

**PHYSICAL SCIENCE**

**0652/06**

Paper 6 Alternative to Practical

**October/November 2010**

**1 hour**

Candidates answer on the Question Paper.

No Additional Materials are required.

**READ THESE INSTRUCTIONS FIRST**

Write your Centre number, candidate number and name on all the work you hand in.

Write in dark blue or black pen.

You may use a soft pencil for any diagrams or graphs.

Do not use staples, paper clips, highlighters, glue or correction fluid.

**DO NOT WRITE IN ANY BARCODES.**

Answer **all** questions.

At the end of the examination, fasten all your work securely together.

The number of marks is given in brackets [ ] at the end of each question or part question.

For Examiner's Use	
1	
2	
3	
4	
5	
6	
<b>Total</b>	

This document consists of **16** printed pages.



- 1 A student finds five old coins. They are all made from a yellow-coloured metal. The teacher tells him that the metal is probably an alloy.

For  
Examiner's  
Use

The student wants to know what metals are contained in the coins.

- (a) (i) The student places the five coins in the pan of a balance. Fig. 1.1 shows the balance window.

Read the mass of the coins and record it in Table 1.1.

[1]

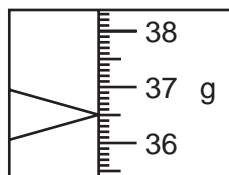

Fig. 1.1

Table 1.1

mass of five coins / g	first level of water / cm <sup>3</sup>	second level of water / cm <sup>3</sup>
	25.0	

- (ii) The student places 25.0 cm<sup>3</sup> of water in a measuring cylinder. Then he drops the coins into the measuring cylinder. The new water level is shown in Fig. 1.2.

Read the scale and record the new water level in Table 1.1.

[1]

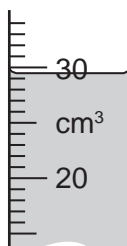

Fig. 1.2

- (iii) Use data from Table 1.1 to calculate the total volume of the five coins.

volume of the five coins ..... cm<sup>3</sup> [1]

- (iv) Use data from Table 1.1 to calculate the density of the metal of the coins.

For  
Examiner's  
Use

density of the metal ..... g/cm<sup>3</sup> [1]

- (b) The student cuts some pieces of metal from one of the coins. He places them in a test-tube and adds dilute hydrochloric acid.

He sees bubbles of a gas being given off. He thinks that the gas is hydrogen. After the reaction has finished, a reddish-brown solid is left in the tube.

- (i) Explain how he can test the gas to show that it is hydrogen. Give the test and result.

description of test .....

.....

result ..... [2]

- (ii) Suggest the name of **one** metal contained in the yellow-coloured alloy that would react with hydrochloric acid to give hydrogen.

..... [1]

- (c) The student washes the reddish-brown residue from (b) with water, then he adds concentrated nitric acid. There is a reaction and a blue solution is formed.

The student thinks that the reddish-brown residue is copper and the blue solution is aqueous copper nitrate. He tests the blue solution using aqueous ammonia.

Complete Table 1.2 to show the results of adding aqueous ammonia to the blue solution, if copper ions are present.

**Table 1.2**

test	result
(i) A small volume of aqueous ammonia is added to the blue solution.	[1]
(ii) Excess aqueous ammonia is added to the mixture from test (i).	[2]

- 2 A student wrote the following statement:  
**“When two lamps are connected in series, the total power output is half of the power output of a single lamp.”**

He tested this statement by doing two experiments shown in Fig. 2.1 and Fig. 2.2.

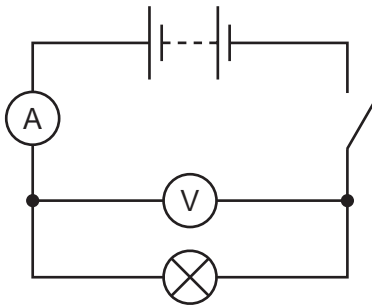

**Fig. 2.1**

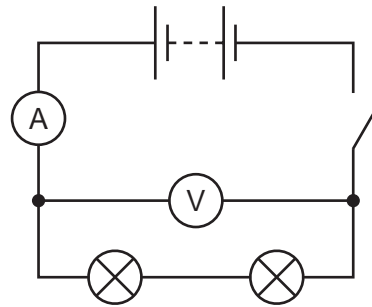

**Fig. 2.2**

- He connected up the circuit shown in Fig. 2.1.
- He closed the switch and read the ammeter and voltmeter, then recorded the readings in Table 2.1.
- He added another lamp, the same as the first lamp, as shown in Fig. 2.2.
- He closed the switch, read the ammeter and voltmeter again and recorded the readings in Table 2.1.

**Table 2.1**

	current / A	voltage / V	power output, equal to current x voltage
<b>single lamp</b>	0.25		
<b>two lamps</b>	0.12		

- (a) (i) Fig. 2.3 shows the voltmeters for the circuits in Fig. 2.1 and Fig. 2.2. Read the voltages and record them in Table 2.1. [2]

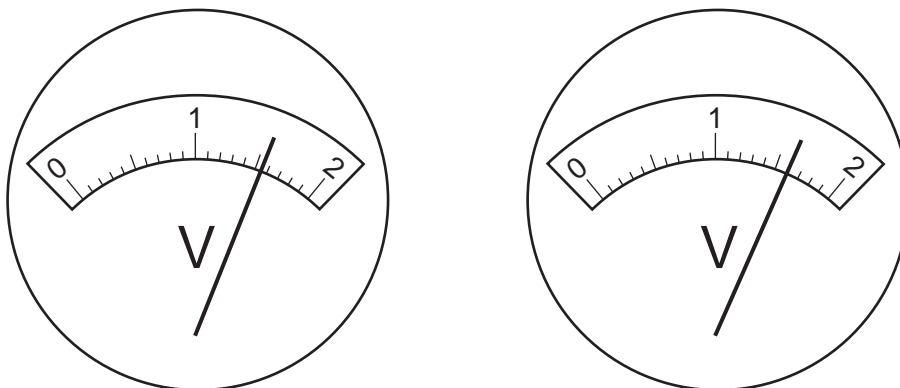

**Fig. 2.3**

- (ii) Find the value of the power for each circuit by multiplying the current by the voltage. Record the values in Table 2.1. [2]
- (iii) What is the unit of power for these values?

..... [1]

Another student wrote the following statement.

**“When two lamps are connected in parallel, the total power output is double that for a single lamp.”**

*For  
Examiner's  
Use*

He altered the circuit shown in Fig. 2.2 so that the two lamps were in parallel.

**(b) (i)** Complete the circuit shown in Fig. 2.4 by drawing two lamps in parallel.

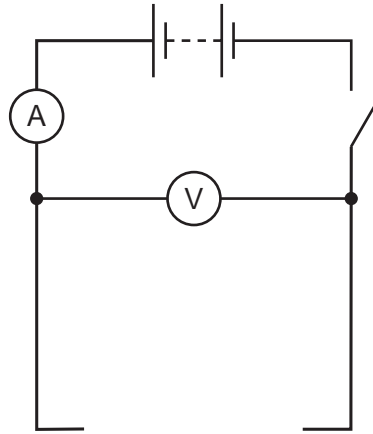

**Fig. 2.4**

[1]

**(ii)** Fig. 2.5 shows the ammeter in the circuit, Fig. 2.4.

[1]

Record the reading in Table 2.2.

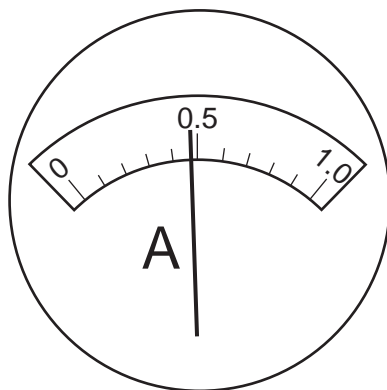

**Fig. 2.5**

**Table 2.2**

ammeter reading / A	voltmeter reading / V	power output, equal to current x voltage
	1.5	

(iii) Complete Table 2.2 by calculating the power output of the lamps.

For  
Examiner's  
Use

[1]

(c) Compare the data in Table 2.1 and Table 2.2. Comment on the **two** statements made by the students.

.....

..... [1]

(d) What other piece of apparatus must be used in an experiment to find the total energy used by the lamps in a circuit?

..... [1]

- 3 The science teacher gives a student a sample of compound **X**. It is a light green crystalline solid. The student carries out the experiments shown in Table 3.1 to find out what compound **X** contains.

For  
Examiner's  
Use

Complete Table 3.1.

**Table 3.1**

test	observations	conclusions
(a) Add compound <b>X</b> to aqueous sodium hydroxide and warm the mixture.	A strong smelling gas is given off. The gas turns litmus ..... [1]	The gas is ..... [1] Compound <b>X</b> contains ..... [1] ions.
(b) Dissolve compound <b>X</b> in water. Divide the resulting solution <b>X</b> into three parts.		
(i) To the first part of solution <b>X</b> , add aqueous sodium hydroxide.	There is a green precipitate which turns brown after standing in air for a few minutes.	The precipitate is ..... [1] hydroxide. This turns to ..... [1] hydroxide by a process known as ..... [1]
(ii) To the second part of solution <b>X</b> , add dilute hydrochloric acid followed by aqueous ..... ..... [1]	..... ..... [1]	Compound <b>X</b> contains sulfate ions.
(iii) To the third part of solution <b>X</b> , add dilute ..... acid followed by aqueous ..... ..... [2]	No precipitate is formed.	Compound <b>X</b> does not contain chloride ions.

- 4 A science student visits a café and notices that a drink is heated by passing steam into it. He decides to do an experiment in the laboratory to find out how steam can heat up water. The apparatus he uses is shown in Fig. 4.1.

For  
Examiner's  
Use

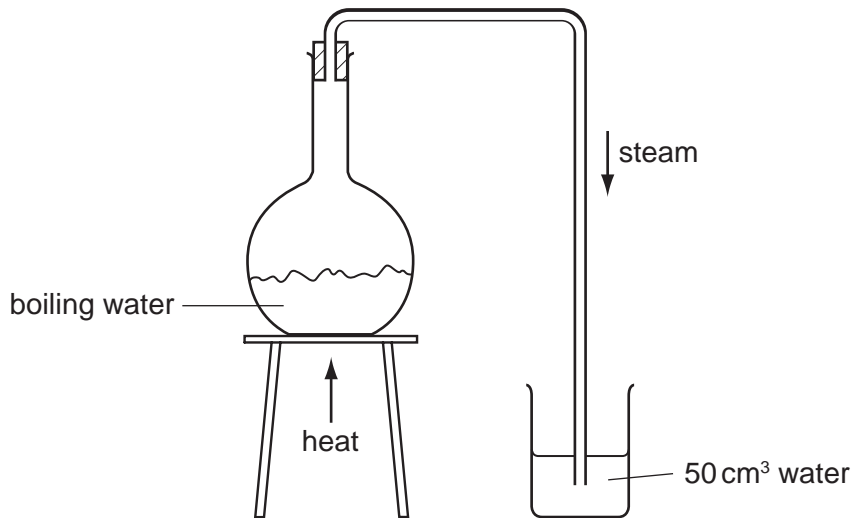

Fig. 4.1

- He places 50 cm<sup>3</sup> of water in a beaker.
- He weighs the beaker containing the water, mass  $m_1$ .
- He finds the temperature of the water, temperature  $t_1$ .
- He passes steam into the water for a few minutes.
- He finds the temperature,  $t_2$ , of the water after passing the steam.
- He weighs the beaker and water again, mass  $m_2$ .

- (a) Read the thermometer scales shown in Fig. 4.2 and record the temperatures  $t_1$  and  $t_2$  in Table 4.1. [2]

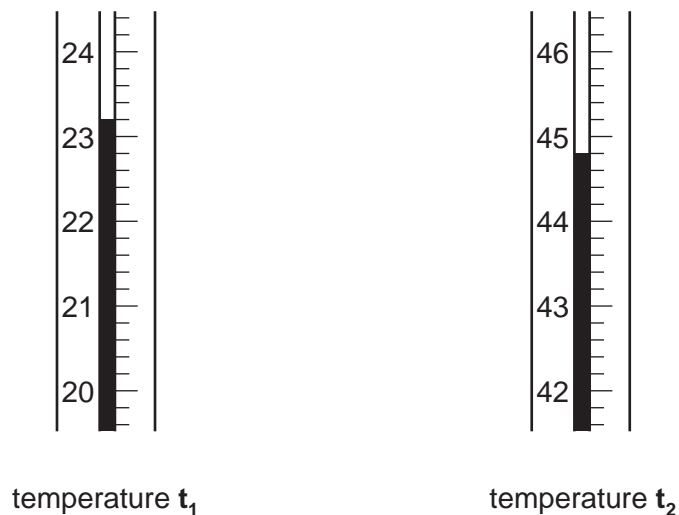

Fig. 4.2



- (b) Read the balance windows shown in Fig. 4.3 and record the masses  $m_1$  and  $m_2$  in Table 4.1. [2]

mass  $m_1$ mass  $m_2$ 

Fig. 4.3

Table 4.1

before passing steam		after passing steam	
temperature $t_1/^\circ\text{C}$		temperature $t_2/^\circ\text{C}$	
mass $m_1/\text{g}$		mass $m_2/\text{g}$	

- (c) Use data from Table 4.1 to calculate the increase in mass of the water in the beaker.

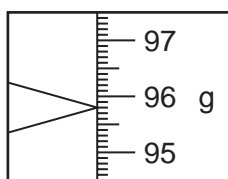
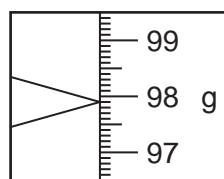
increase in mass = ..... g [1]

- (d) Use data from Table 4.1 to calculate the increase in temperature of the water in the beaker.

increase in temperature = .....  $^\circ\text{C}$  [1]

For  
Examiner's  
Use

(e) (i) Name the physical change in the following process;

steam at 100 °C → water at 100 °C

..... [1]

(ii) Use your knowledge of the Kinetic Theory to explain why heat is given out during this process.

.....  
.....  
..... [2]

(f) The student decides that, in addition to the heat referred to in (e)(ii), some more heat was given to the water in the beaker to raise it from temperature  $t_1$  to temperature  $t_2$ .

Explain where this extra heat came from.

.....  
..... [1]

- 5 A science student saw a man using a wheelbarrow to carry a heavy object. He measured the wheelbarrow and drew a diagram, Fig. 5.1.

For  
Examiner's  
Use

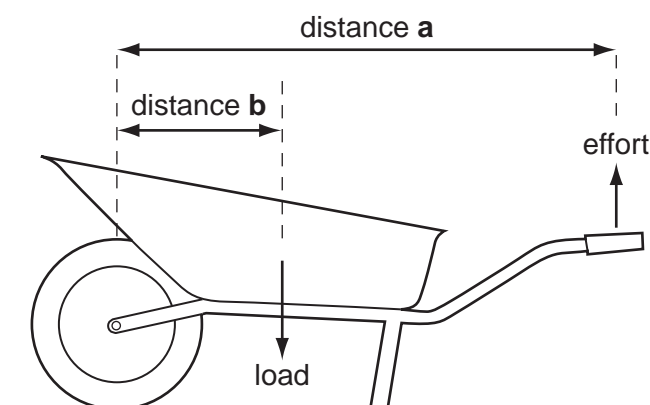

Fig. 5.1

The student then decided to do an experiment to show how the man can lift the heavy load in the wheelbarrow.

He set up the apparatus shown in Fig. 5.2. He used a bar the same length as the wheelbarrow, pivoted at one end. At the other end, he used a newton-meter to find the effort needed to raise the bar.

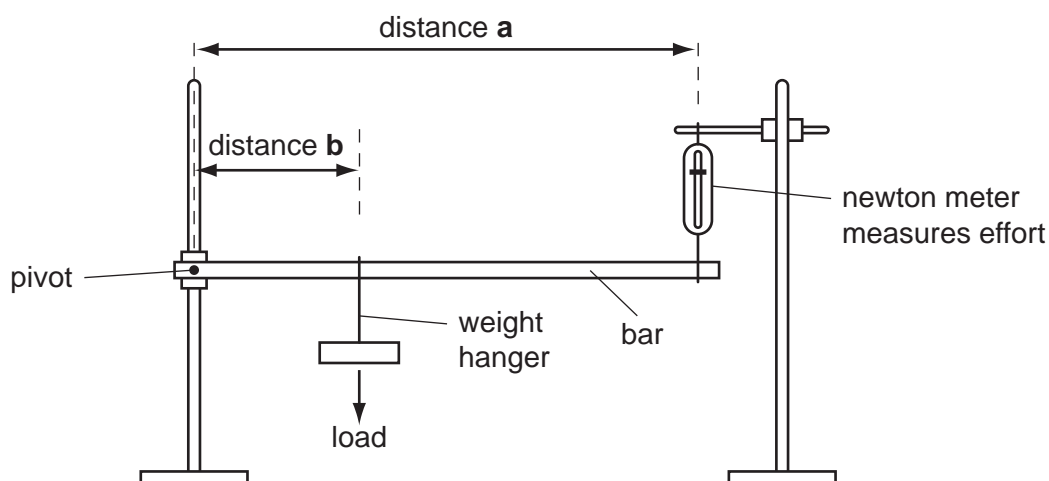

Fig. 5.2

The load was suspended from a weight hanger. Distances **a** and **b** shown in Fig. 5.2 were the same as distances **a** and **b** in Fig. 5.1.

- He recorded, in Table 5.1, the reading on the newton-meter with no mass on the weight hanger.
- Then he placed a 200 g mass on the weight hanger and recorded the new reading on the newton meter.
- He repeated the procedure, adding further masses, until the mass on the weight hanger was 1200 g.

Table 5.1

<b>load/g</b>	0	200	400	600	800	1000	1200
<b>load/newtons</b>	0						
<b>effort/newtons</b>	1.5	2.3	3.1	3.8			

For  
Examiner's  
Use

(a) (i) Fig. 5.3 shows the scale of the newton-meter for the last three values of the effort.

Read the scales and record the readings in Table 5.1.

[3]

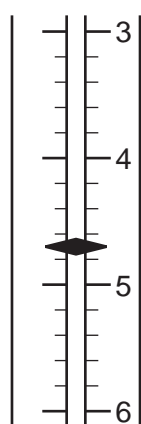

load = 800 g

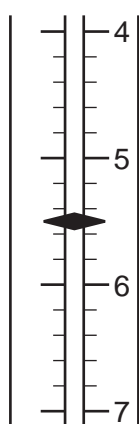

load = 1000 g

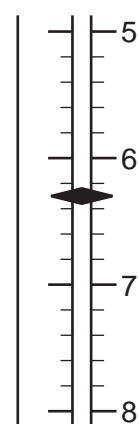

load = 1200 g

Fig. 5.3

(ii) Convert the load in grams to weight in newtons and complete Table 5.1.  
(1000 g mass = 10 newtons)

[1]

- (b) (i) On the grid provided, plot a graph of load in newtons (vertical axis) against effort in newtons. Draw the best straight line.

For  
Examiner's  
Use

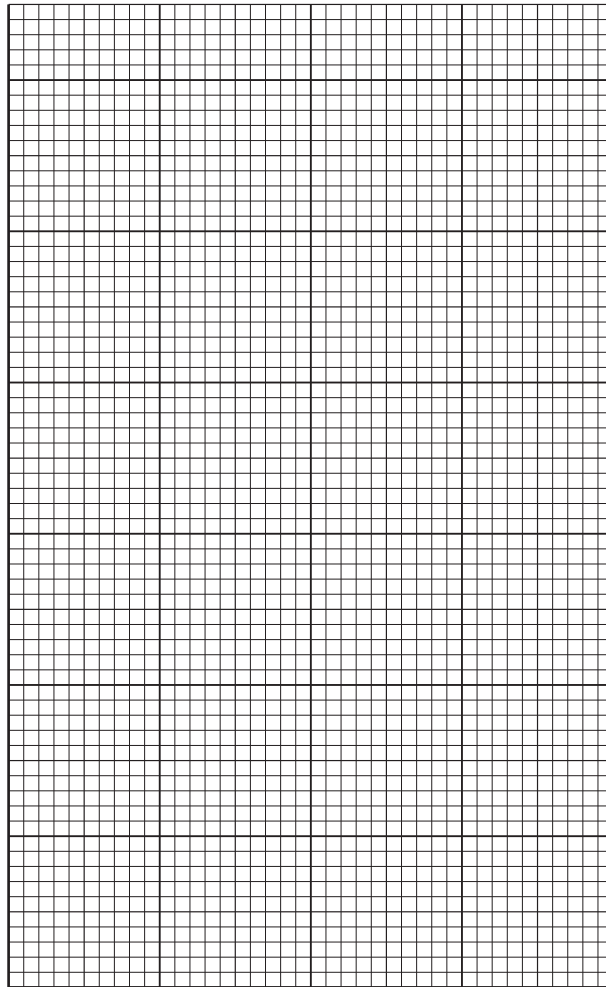

[3]

- (ii) Use the slope of the graph to find a value for **Y** in the equation.

$$\text{load in newtons} = Y \times \text{effort in newtons}$$

Show how you do this on the graph.

$$Y = \dots\dots\dots [2]$$

- (iii) Use the value of **Y** you have calculated in (c)(ii) to find the effort needed to lift a total wheelbarrow load of 400 kg. (1 kg = 1000 g)

$$\text{effort needed} \dots\dots\dots \text{newtons} [1]$$

- 6 The science class is investigating the properties of the halogens chlorine,  $\text{Cl}_2$ , bromine,  $\text{Br}_2$ , and iodine,  $\text{I}_2$ . The teacher shows them samples of the three elements, shown in Fig. 6.1.

For  
Examiner's  
Use



Fig. 6.1

- (a) State the colour of
- (i) liquid bromine, .....
- (ii) solid iodine. .... [2]
- (b) The teacher places a few  $\text{cm}^3$  of water in the gas-jar of chlorine and quickly closes the lid. She shakes the jar to make the chlorine dissolve in the water. She pours the water out into a beaker and tests it with a piece of blue litmus paper.
- What happens to the colour of the litmus paper?
- .....
- ..... [1]
- (c) The teacher places a few  $\text{cm}^3$  of aqueous potassium iodide,  $\text{KI}$ , in a gas-jar of chlorine. The colourless liquid turns brown. Then she adds two drops of starch solution.
- (i) What is seen when the starch solution is added?
- ..... [1]
- (ii) Write a balanced equation for the reaction between chlorine and potassium iodide.
- ..... [2]

- (d) Fig. 6.2 shows the next experiment. The teacher places one drop of bromine in 50 cm<sup>3</sup> of water in a beaker. She stirs the mixture to make the bromine dissolve.

She places 10 cm<sup>3</sup> samples of the bromine water in each of three gas-jars. Each gas-jar contains one of the gases ethane, ethene and methane. She shakes the jars. The bromine water in one of the jars loses its colour.

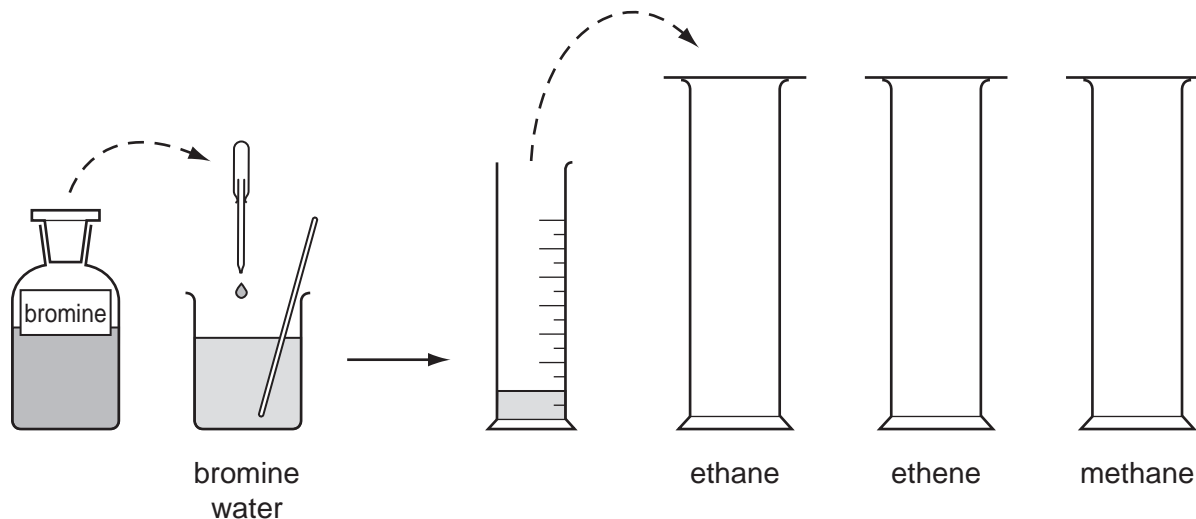

Fig. 6.2

- (i) Which gas, ethane, ethene or methane, reacts with the bromine?

..... [1]

- (ii) What does this show about the structure of the molecules of the gas that reacts?

.....  
..... [1]

- (e) The teacher gives a student a crystal of iodine in a dry test-tube. She tells her to warm the test-tube using a small flame. Fig. 6.3 shows the student's diagram of the result.

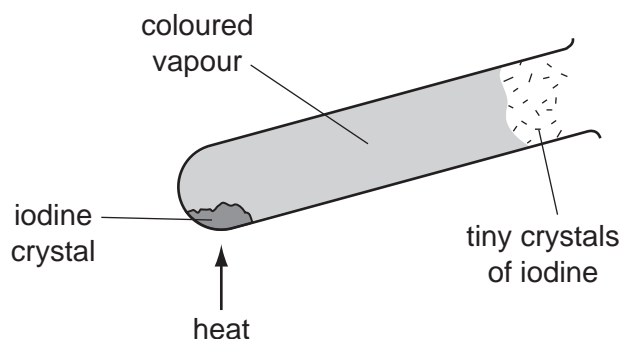

Fig. 6.3

- (i) What is the colour of the vapour?

..... [1]

(ii) What name is given to the change **from** a vapour **to** a solid?

..... [1]

---

Permission to reproduce items where third-party owned material protected by copyright is included has been sought and cleared where possible. Every reasonable effort has been made by the publisher (UCLES) to trace copyright holders, but if any items requiring clearance have unwittingly been included, the publisher will be pleased to make amends at the earliest possible opportunity.

University of Cambridge International Examinations is part of the Cambridge Assessment Group. Cambridge Assessment is the brand name of University of Cambridge Local Examinations Syndicate (UCLES), which is itself a department of the University of Cambridge.