



UNIVERSITY OF CAMBRIDGE INTERNATIONAL EXAMINATIONS
International General Certificate of Secondary Education

PHYSICAL SCIENCE

0652/01

Paper 1 Multiple Choice

October/November 2007

45 minutes

Additional Materials: Multiple Choice Answer Sheet
 Soft clean eraser
 Soft pencil (type B or HB is recommended)



READ THESE INSTRUCTIONS FIRST

Write in soft pencil.

Do not use staples, paper clips, highlighters, glue or correction fluid.

Write your name, Centre number and candidate number on the Answer Sheet in the spaces provided unless this has been done for you.

There are **forty** questions on this paper. Answer **all** questions. For each question there are four possible answers **A, B, C** and **D**.

Choose the **one** you consider correct and record your choice in **soft pencil** on the separate Answer Sheet.

Read the instructions on the Answer Sheet very carefully.

Each correct answer will score one mark. A mark will not be deducted for a wrong answer.

Any rough working should be done in this booklet.

A copy of the Periodic Table is printed on page 20.

This document consists of **18** printed pages and **2** blank pages.



- 1 Diffusion involves the movement of particles.

For example, particles in a ...1... travel from a region of ...2... concentration to a region of ...3... concentration.

Which words are correct for 1, 2 and 3?

	1	2	3
A	gas	high	low
B	gas	low	high
C	liquid	low	high
D	solid	high	low

- 2 A student measures the mass of a volume of liquid by using the apparatus below.

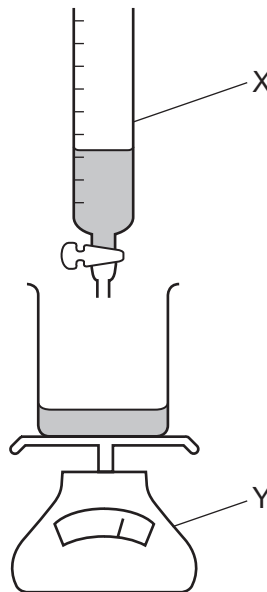

What are the correct labels for X and Y?

	X	Y
A	balance	burette
B	burette	pipette
C	burette	balance
D	pipette	balance



3 Element **Z** conducts electricity and forms a basic oxide.

What could **Z** be?

	Na	Mg	S	Cl
A	✓	x	x	x
B	✓	✓	x	x
C	x	x	x	✓
D	x	x	✓	✓

4 Two isotopes of hydrogen are ${}^1_1\text{H}$ and ${}^2_1\text{H}$.

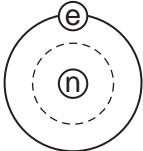
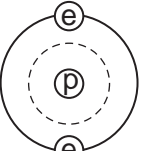
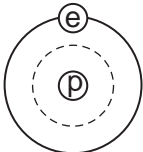
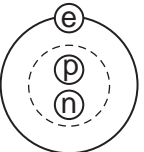
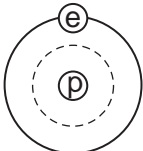
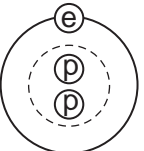
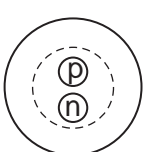
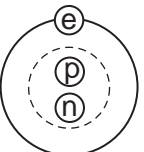
Which diagram shows the arrangement of particles in the two isotopes?

	${}^1_1\text{H}$	${}^2_1\text{H}$	
A			key
B			⊕ = an electron
C			⊙ = a proton
D			⊖ = a neutron
			 = a nucleus

5 Which formula represents a **molecule** that contains 3 atoms?

A HBr

B MgO

C NH₃

D SCl₂

6 The production of energy is important.

Fuel ...1..., burns in an ...2... reaction.

What could 1 and 2 be?

	1	2
A	hydrogen	endothermic
B	hydrogen	exothermic
C	oxygen	endothermic
D	oxygen	exothermic

7 The diagram shows apparatus being used to fill a balloon with hydrogen.

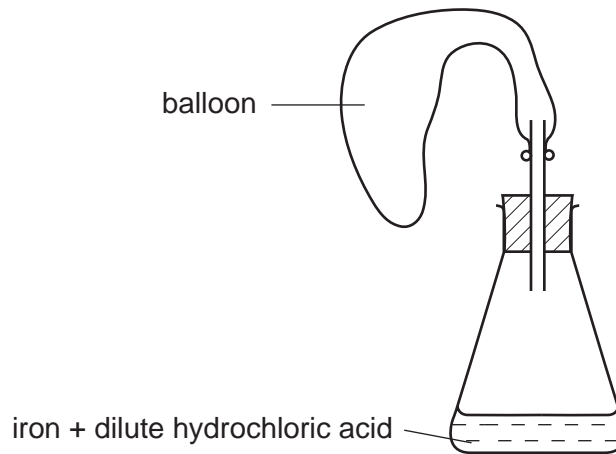

Which form of iron makes the balloon fill most quickly?

- A** a lump
- B** pieces of wire
- C** a powder
- D** thin sheets

- 8 The diagram shows an experiment in which magnesium powder is added to dilute sulphuric acid.

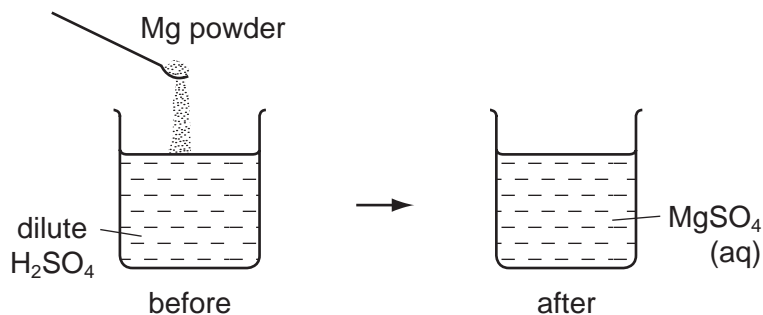

Which statement correctly compares the pH and temperature of the final solution with the values of the original acid?

	final solution has	
	higher pH	higher temperature
A	✓	✓
B	✓	✗
C	✗	✓
D	✗	✗

- 9 Which two salts are each soluble in water?

- A** barium chloride and barium sulphate
- B** barium sulphate and silver chloride
- C** silver chloride and silver nitrate
- D** silver nitrate and barium chloride

- 10 Hydrochloric acid is used to clean metals.

The acid reacts with the oxide layer on the surface of the metal, forming a salt and water.

Which word describes the metal oxide?

- A** alloy
- B** base
- C** element
- D** indicator

15 Why is mild steel used instead of iron to make car bodies?

- A Iron cannot be painted.
- B Mild steel does not rust.
- C Mild steel is more brittle than iron.
- D Mild steel is stronger than iron.

16 Urea, $\text{CO}(\text{NH}_2)_2$, is used as a fertiliser.

Which element that plants need is provided by the urea?

- A carbon
- B hydrogen
- C nitrogen
- D oxygen

17 In experiments on rusting, some students are given metal objects to study.

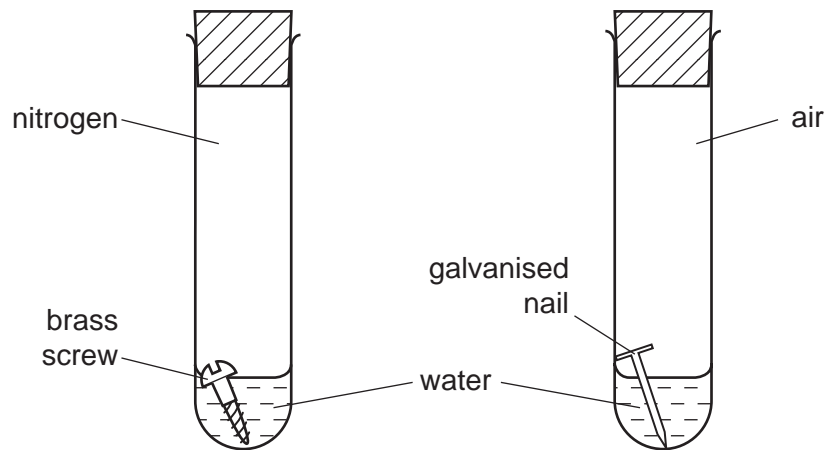

One student set up his apparatus as shown.

Which object rusted?

	brass screw	galvanized nail
A	✓	✓
B	✓	x
C	x	✓
D	x	x

21 Some water is poured into four tubes of different cross-sectional areas.

Which tube contains the largest volume of water?

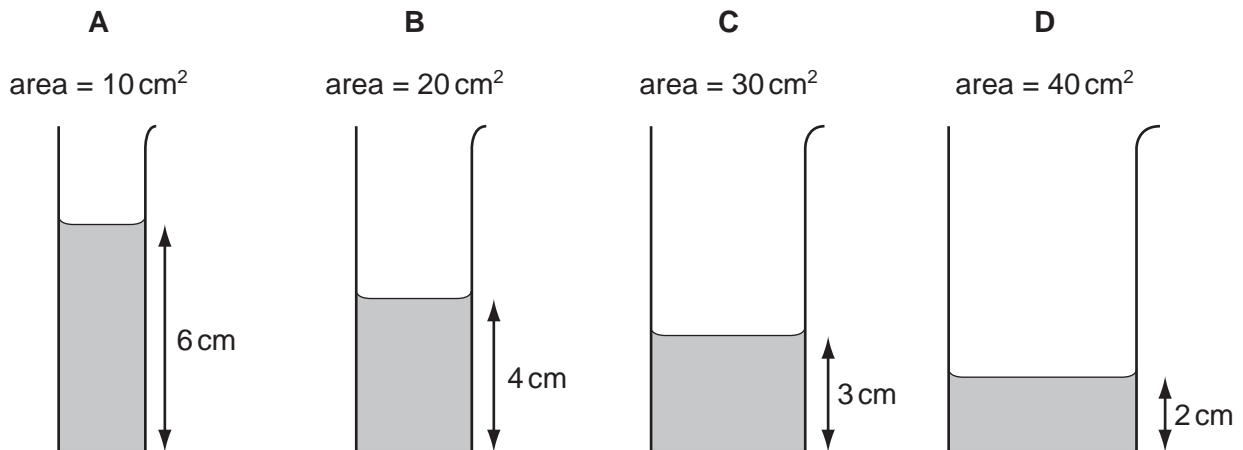

22 Four students try to explain what is meant by acceleration.

Which student makes a correct statement?

- A** It is related to the changing speed of an object.
- B** It is the distance an object travels in one second.
- C** It is the force acting on an object divided by the distance it travels in one second.
- D** It is the force acting on an object when it is near to the Earth.

23 The table shows the weight of a 10 kg mass on each of five planets.

planet	weight of a 10 kg mass/N
Mercury	40
Venus	90
Earth	100
Mars	40
Jupiter	250

On which planets would an astronaut have a smaller weight than on Earth?

- A** Mercury, Mars and Jupiter
- B** Mercury, Venus and Mars
- C** Mercury, Venus and Jupiter
- D** Venus, Mars and Jupiter

- 24 A metal drum has a mass of 200 kg when empty and 1000 kg when filled with 1.0 m^3 of methylated spirit.

What is the density of methylated spirit?

- A 0.0050 kg/m^3
B 0.11 kg/m^3
C 800 kg/m^3
D 1000 kg/m^3
- 25 An empty glass is placed on a join between two tables as shown. The glass remains stable.

Which point is the centre of mass of the glass?

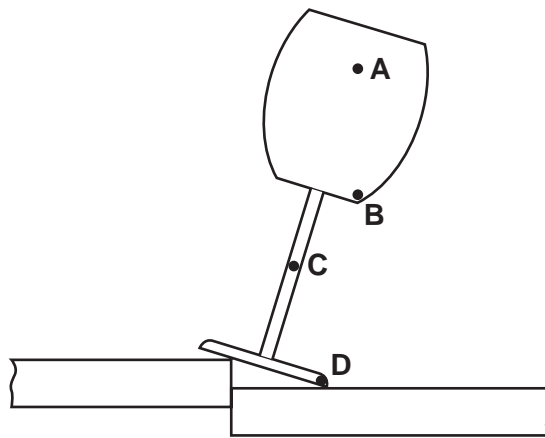

26 A spring is suspended from a stand. Loads are added and the extensions are measured.

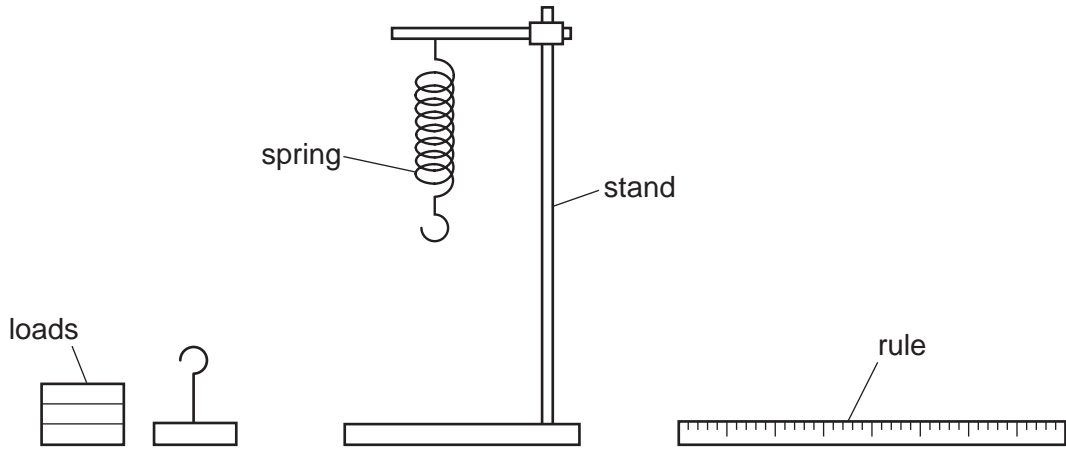

Which graph shows the result of plotting extension against load?

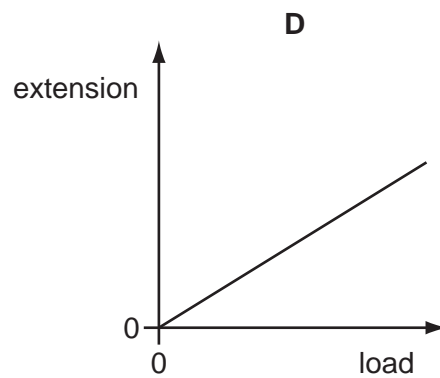
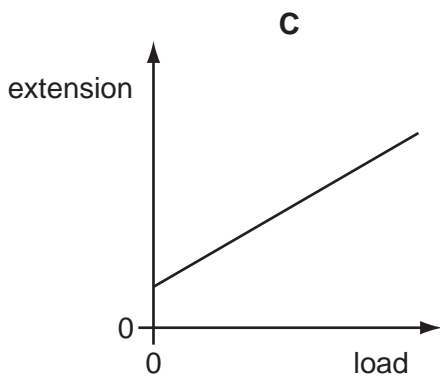
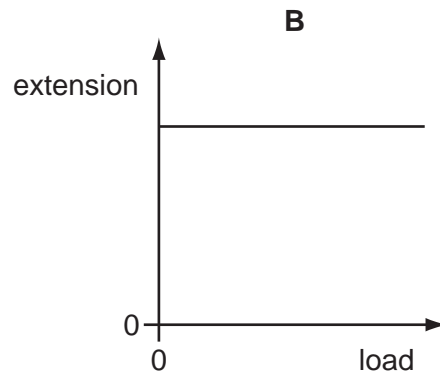
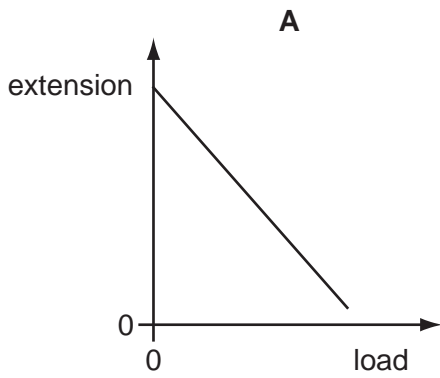

27 A person uses chemical energy to run up some stairs.

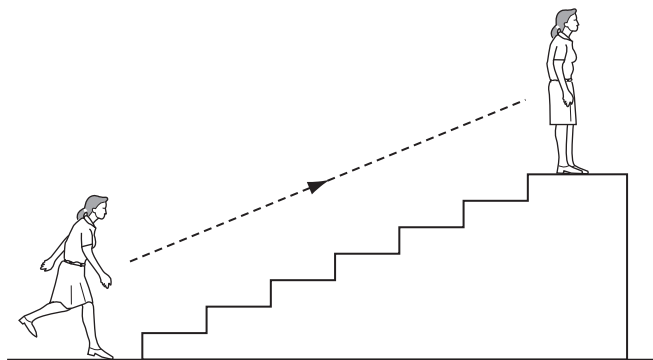

She stops at the top of the stairs.

What has the chemical energy been converted to when she is at the top of the stairs?

- A energy of motion and gravitational energy
 - B energy of motion and strain energy
 - C gravitational energy and heat energy
 - D strain energy and heat energy
- 28 A wooden wheel can be strengthened by putting a tight circle of iron around it.

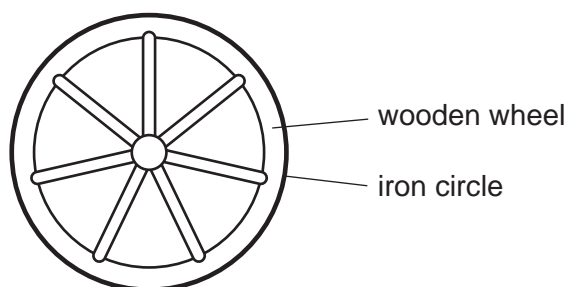

Which action would make it easier to fit the circle over the wood?

- A cooling the iron circle
 - B heating the iron circle
 - C heating the wooden wheel
 - D heating the wooden wheel and cooling the iron circle
- 29 Which statement refers to convection?
- A It does not involve energy transfer.
 - B It is the transfer of heat energy without the movement of particles.
 - C It only occurs in liquids or gases.
 - D It only occurs in solids.

30 The diagram shows a section through a series of waves on water.

Which dotted line shows the position of the still water surface after the waves have passed?

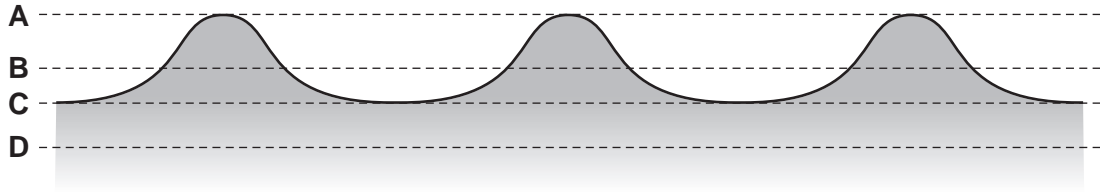

31 An object placed in front of a plane mirror at O produces an image at I.

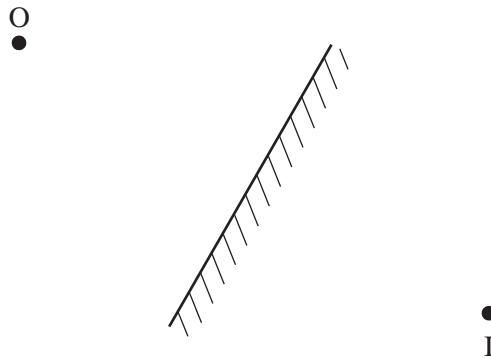

If the object moves towards the mirror in the direction shown by the arrow, in which direction does the image move?

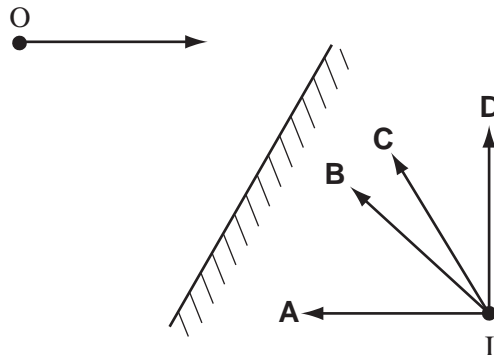

32 Which materials are suitable for making a permanent magnet and the core of an electromagnet?

	permanent magnet	core of an electromagnet
A	iron	iron
B	iron	steel
C	steel	iron
D	steel	steel

- 33 Three charged balls, P, Q and R, are suspended by insulated threads. Ball P is negatively charged.

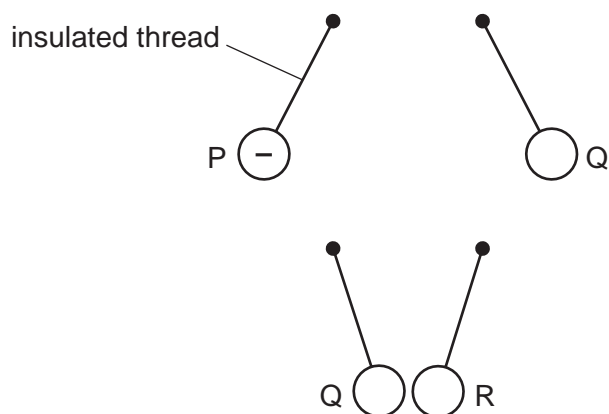

What are the charges on Q and on R?

	Q	R
A	positive	positive
B	positive	negative
C	negative	positive
D	negative	negative

- 34 The circuit shows a current I in a resistor of resistance R .

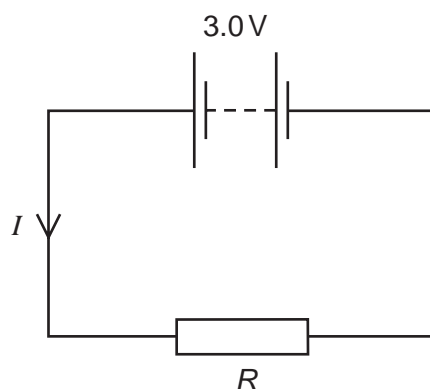

Which line gives possible values of I and R ?

	I/A	R/Ω
A	1.5	1.5
B	1.5	2.0
C	6.0	2.0
D	4.0	12

35 Four lamps are connected in a circuit as shown in the diagram.

Each lamp is designed to operate at 12 V.

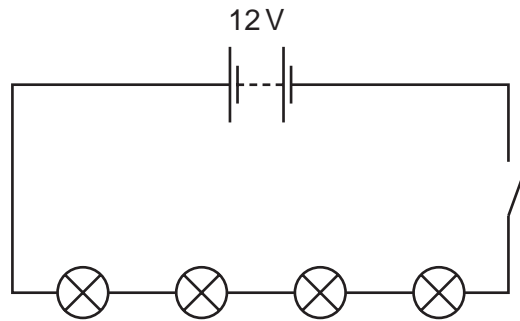

The circuit is now switched on.

Which statement is correct?

- A Each lamp can be switched off independently.
 - B If one lamp breaks all the others will stay alight.
 - C The current is the same in all the lamps.
 - D The lamps will all light at normal brightness.
- 36 A mains electrical circuit uses insulated copper cable and the cable overheats. To prevent the cable overheating, how should the cable be changed, and why?
- A Use thicker copper cable which has less resistance.
 - B Use thicker insulation which stops the heat escaping.
 - C Use thinner copper cable which has more resistance.
 - D Use thinner insulation which allows less heat to escape.

37 The diagram shows a cathode-ray tube.

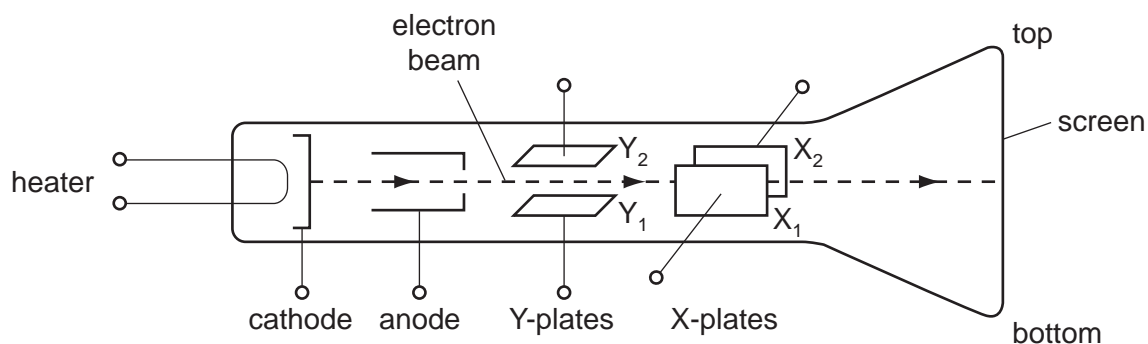

What must be done to deflect the electron beam upwards?

- A make X_1 more positive than X_2
- B make X_2 more positive than X_1
- C make Y_1 more positive than Y_2
- D make Y_2 more positive than Y_1

38 A sheet of paper is placed between a radioactive source and a detector.

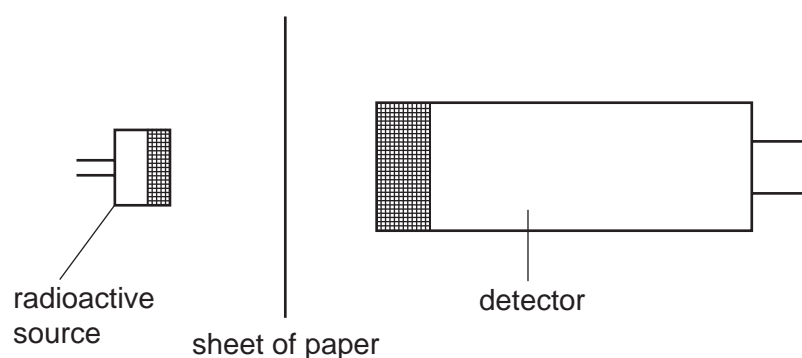

Which types of radiation can pass through the paper?

- A alpha-particles and beta-particles only
- B alpha-particles and gamma-rays only
- C beta-particles and gamma-rays only
- D alpha-particles, beta-particles and gamma-rays

39 A sample of radioactive isotope is decaying.

The nuclei of which atoms will decay first?

- A impossible to know, because radioactive decay is random
- B impossible to know, unless the age of the material is known
- C atoms near the centre, because they are surrounded by more atoms
- D atoms near the surface, because the radiation can escape more easily

40 An atom of the element lithium has a nucleon number of 7 and a proton number of 3.

Which diagram represents a neutral atom of lithium?

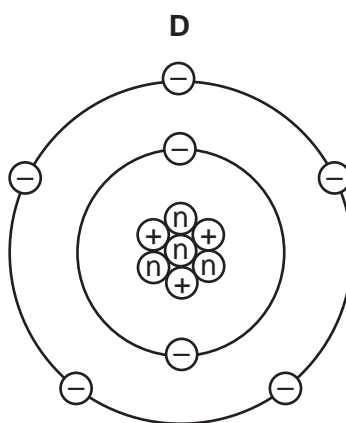
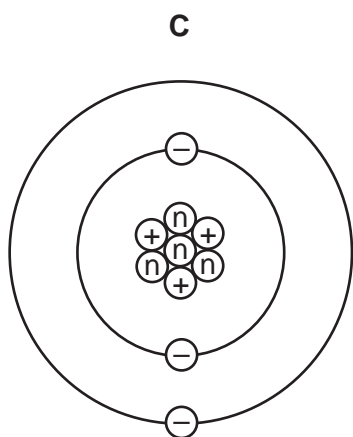
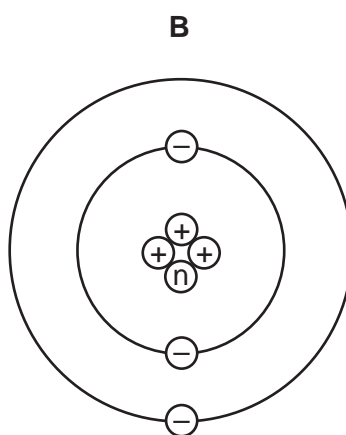
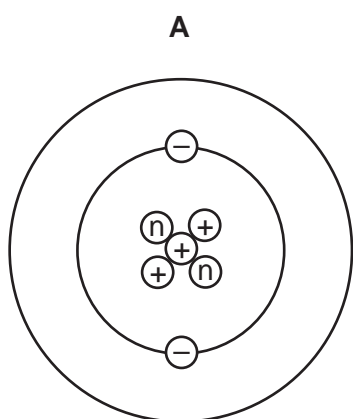

key

Ⓝ = a neutron

⊕ = a proton

⊖ = an electron

(not to scale)

