

Centre Number	Candidate Number	Name
---------------	------------------	------

CAMBRIDGE INTERNATIONAL EXAMINATIONS
International General Certificate of Secondary Education

PHYSICAL SCIENCE

0652/03

Paper 3

October/November 2003

1 hour 15 minutes

Candidates answer on the Question Paper.
No Additional Materials are required.

READ THESE INSTRUCTIONS FIRST

Write your Centre number, candidate number and name on all the work you hand in.
Write in dark blue or black pen in the spaces provided on the Question Paper.
You may use a pencil for any diagrams, graphs, tables or rough working.
Do not use staples, paper clips, highlighters, glue or correction fluid.

Answer **all** questions.
At the end of the examination, fasten all your work securely together.
The number of marks is given in brackets [] at the end of each question or part question.
A copy of the Periodic Table is printed on page 16.

For Examiner's Use	
1	
2	
3	
4	
5	
6	
7	
8	
9	
Total	

If you have been given a label, look at the details. If any details are incorrect or missing, please fill in your correct details in the space given at the top of this page.

Stick your personal label here, if provided.

This document consists of **15** printed pages and **1** blank page.



1 The soluble salts of most metals can be prepared by adding the insoluble carbonate of the metal to the appropriate acid until excess carbonate is present.

(a) Name the acid which would be added to copper(II) carbonate to produce copper(II) nitrate.

.....[1]

(b) Write a balanced equation for the reaction.

.....[2]

(c) Describe the changes that you would observe during this reaction.

.....

.....

.....[2]

(d) Describe how you would obtain a solid sample of the copper(II) nitrate.

.....

.....

.....[2]

(e) Suggest why it is not possible to use a similar method to prepare the salt sodium nitrate.

.....

.....[1]

- 2 A student designs the apparatus of Fig. 2.1 as a device to detect thermal radiation. The flask is tightly covered with a material that absorbs thermal radiation well.

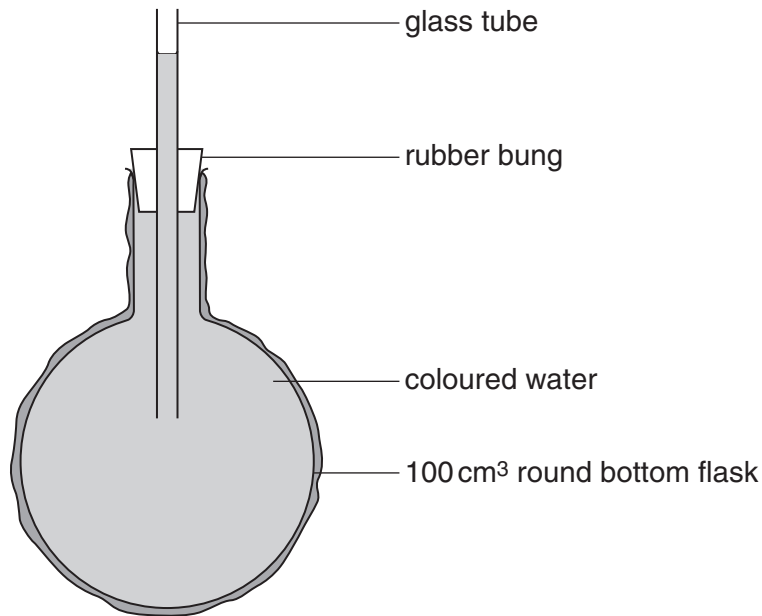

Fig. 2.1

- (a) (i) Describe the appearance of the material that the student should use to cover the flask and explain why it would be effective for absorbing thermal radiation.

.....
.....
.....
.....
.....
.....
.....[3]

- (ii) Describe and explain what the student would see when intense thermal radiation is shone onto the apparatus.

.....
.....
.....
.....
.....
.....[2]

(b) (i) Explain why the apparatus is **not** likely to detect low intensity thermal radiation.

.....
.....
.....

[2]

(ii) State and explain **two** changes that could be made in order to improve the effectiveness of this apparatus.

.....
.....
.....
.....
.....
.....
.....
.....
.....
.....

[4]

- 3 The diagrams in Fig. 3.1 show the crystal structures of two forms of the element carbon.

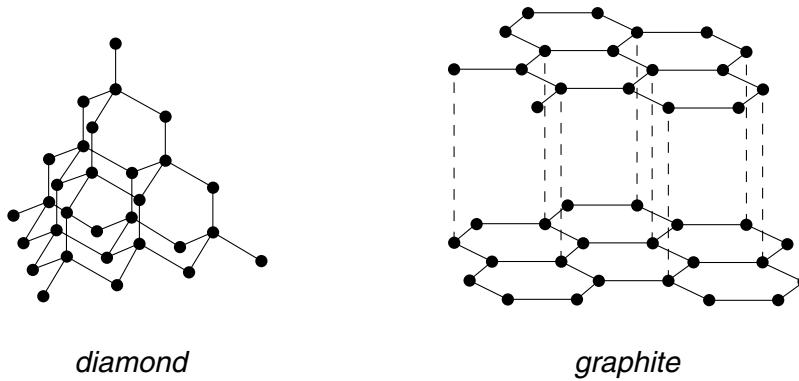

Fig. 3.1

In diamond crystals every carbon atom is linked to four other carbon atoms by covalent bonds.

In graphite each carbon atom is linked to three other carbon atoms by covalent bonds to form layers. The fourth outer shell electrons in the carbon atoms then form delocalised layers of electrons.

- (a) Explain how these differences in the crystal structures produce differences in the following properties of the two forms

- (i) hardness,

.....

.....

.....

.....[2]

- (ii) electrical conductivity.

.....

.....

.....

.....[2]

(b) During combustion, carbon and many of its compounds combine with oxygen to form two different oxides, carbon monoxide and carbon dioxide.

(i) Draw a diagram to show the formation of the bonds in carbon dioxide.

You need only show the outer shell electrons in each atom.

[2]

(ii) State the condition needed for combustion to form carbon monoxide rather than carbon dioxide.

.....

.....[1]

(iii) Explain how carbon monoxide affects the respiration of mammals.

.....

.....[1]

[Question 4 can be found on page 8]

- 4 A cathode-ray oscilloscope (c.r.o.) is used to investigate the circuit of Fig. 4.1.

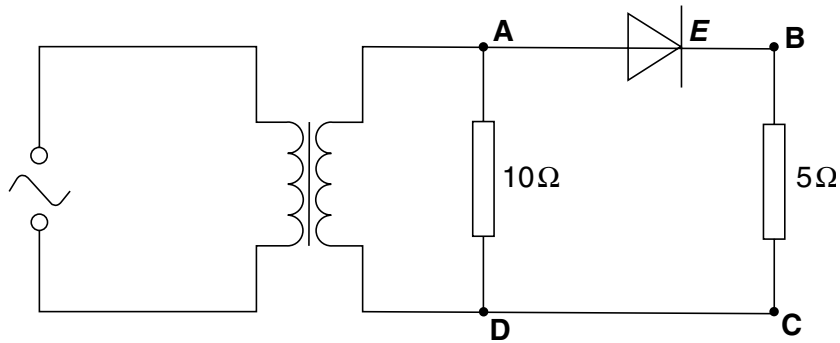

Fig. 4.1

Fig. 4.2 shows the trace on the oscilloscope screen together with the time-base and y-gain (voltage) settings when the oscilloscope is connected across **AD**.

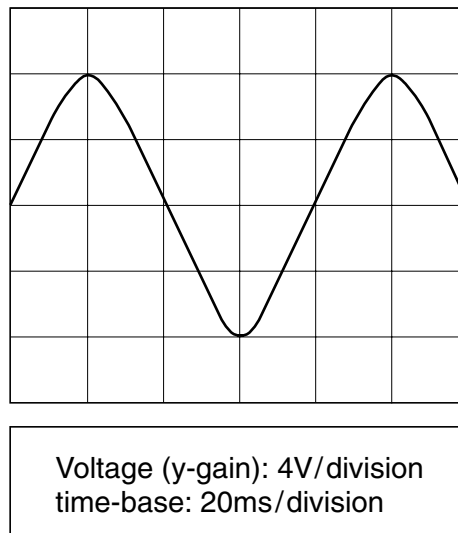

Fig. 4.2

- (a) (i) Calculate the peak voltage (amplitude) across **AD**.

peak voltage = V [2]

- (ii) Calculate the peak current in the $10\ \Omega$ resistor.

current = [2]

- (iii) The primary (input) coil of the transformer has 30 turns and the secondary has 20 turns.

Calculate the peak input voltage supplied to the transformer.

Write down the equation that you use and show all your working.

voltage supplied =V [3]

- (iv) Calculate the time taken for one complete cycle of the a.c. supply.

time for one cycle = [3]

- (b) (i) Name the component labelled **E** in Fig. 4.1.

.....[1]

- (ii) On Fig. 4.3, draw the trace that would be seen if the c.r.o. were connected across **BC**.

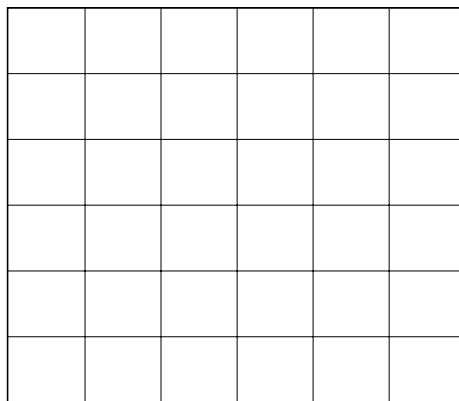

Voltage (y-gain): 4V/division
time-base: 20ms/division

Fig. 4.3

[1]

- 5 Fig. 5.1 shows an experiment to compare the rates of movement of two gases.

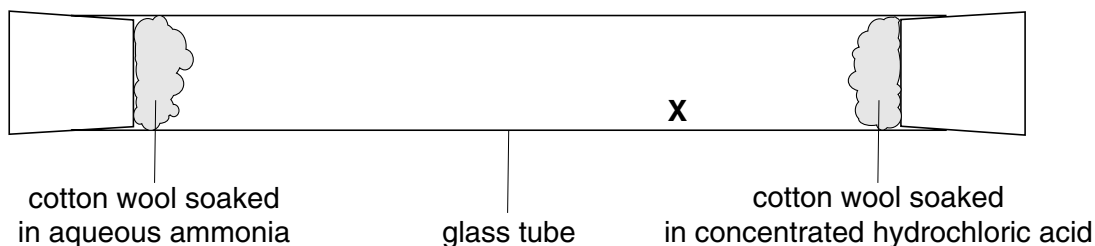
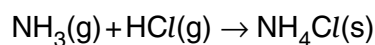

Fig. 5.1

After a few minutes, solid ammonium chloride appears at **X** inside the tube.

The equation for the reaction that occurs can be written as below.



- (a) Name the process by which the two gases move along the tube.[1]

- (b) Suggest and explain why the solid is formed nearer to the end where the hydrogen chloride enters the tube.

.....

[2]

- (c) Explain this reaction in terms of proton transfer.

.....

[2]

- (d) Describe the chemical test that you could perform to show that the solid contained ammonium ions and state the result you would expect.

test

.....

result

.....

[2]

6 (a) Define *refractive index*.

.....
.....
.....[2]

(b) Fig. 6.1 shows a fish below the surface of water in a lake.

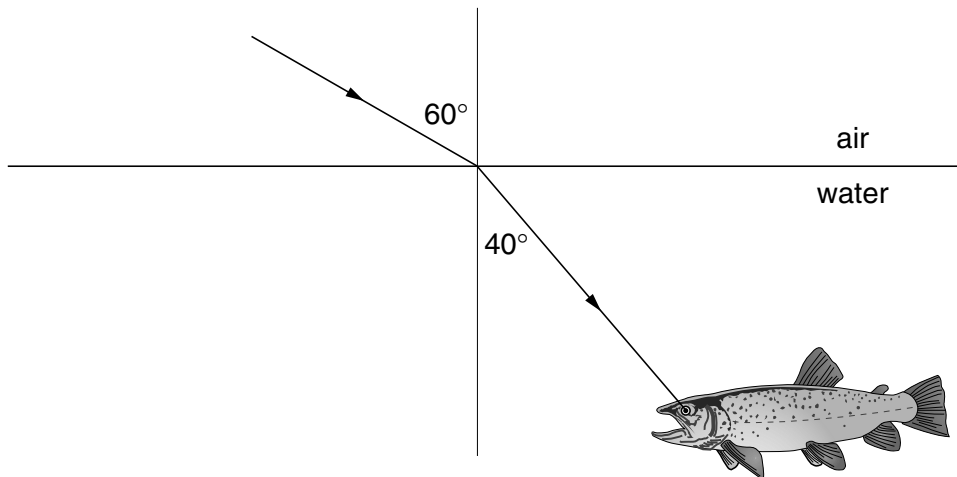

Fig. 6.1

(i) Explain why refraction means that the fish can see through a wider range of angles than if there were no water present.

.....
.....
.....[2]

(ii) Calculate the refractive index of the water in the lake.

Write down the equation that you use and show all your working.

refractive index = [3]

7 Aluminium is a metallic element in Group III of the Periodic Table. Aluminium oxide is amphoteric.

(a) Write the formula for aluminium oxide.[1]

(b) Explain the meaning of the term *amphoteric*.

.....
.....
.....[2]

(c) State one use of aluminium and describe two properties that make it suitable for that use.

use

first property

.....

second property

.....[3]

(d) Thallium is below aluminium in Group III of the Periodic Table.

Suggest, with a reason, the class of oxide that you would expect thallium to form.

.....
.....
.....[2]

- 8 The apparatus of Fig. 8.1 is used to take readings from which to calculate the acceleration of free fall.

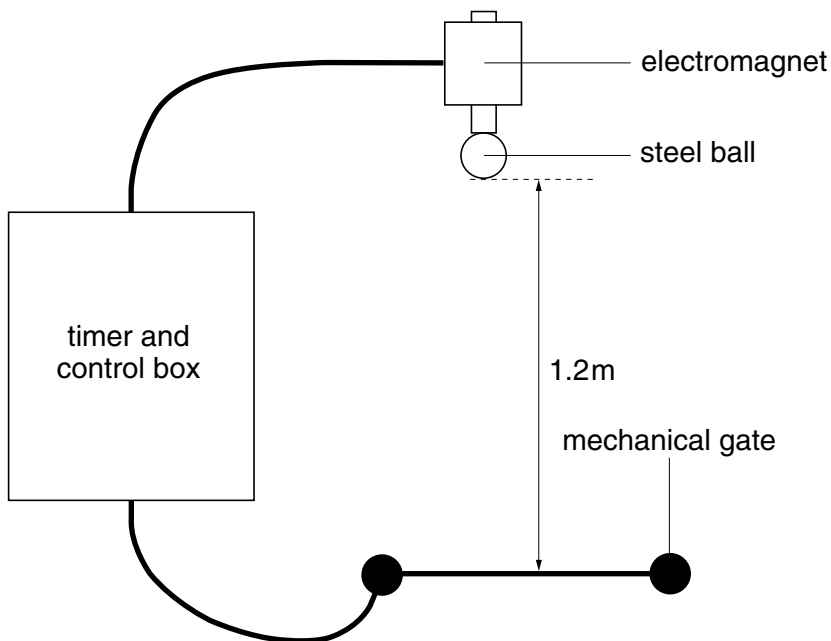

Fig. 8.1

As the control box is switched on the timer starts. At the same instant the steel ball is released from rest. When the ball hits the gate this opens and stops the timer. The mass of the ball is 20.0 g.

- (a) Explain what causes the steel ball to be released.

.....

 [2]

- (b) Calculate the weight of the ball in newton.

[$g = 10 \text{ N/kg}$]

weight = N [2]

(c) Explain whether air resistance is likely to affect the motion of the ball as it falls.

.....
.....
.....[2]

(d) The time measured for the ball to fall a distance of 1.2 m is 0.48 s. Calculate a value for the acceleration of free fall (g), using these values. Show your working.

$g = \dots\dots\dots [4]$

- 9 One method of preparing ethanol is the fermentation of glucose. The equation for this process can be summarised as shown below.

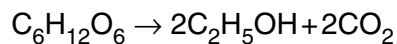

- (a) State the **three** essential conditions for fermentation to take place.

.....

 [3]

- (b) (i) Calculate the relative molecular mass, M_r , of glucose and of ethanol.

[Ar: H, 1; C, 12; O, 16.]

[2]

M_r of glucose M_r of ethanol

- (ii) Hence find the mass of ethanol that could be obtained from 36 g of glucose.

mass of ethanol = [2]

- (iii) Calculate the volume of carbon dioxide at room temperature and pressure, r.t.p., produced by fermentation of 36 g of glucose.

1 mole of any gas occupies 24 dm³ at r.t.p.

volume of carbon dioxide = [2]

