

Centre Number	Candidate Number	Name
---------------	------------------	------

CAMBRIDGE INTERNATIONAL EXAMINATIONS
International General Certificate of Secondary Education

PHYSICAL SCIENCE

0652/01

Paper 1 Multiple Choice

October/November 2003

45 minutes

Additional Materials: Multiple Choice Answer Sheet
Soft clean eraser
Soft pencil (type B or HB is recommended)

READ THESE INSTRUCTIONS FIRST

Write in soft pencil.

Do not use staples, paper clips, highlighters, glue or correction fluid.

Write your name, Centre number and candidate number on the answer sheet in the spaces provided unless this has been done for you.

There are **forty** questions on this paper. Answer **all** questions. For each question there are four possible answers **A, B, C, and D**.

Choose the **one** you consider correct and record your choice in **soft pencil** on the separate answer sheet.

Read the instructions on the Answer Sheet very carefully.

Each correct answer will score one mark. A mark will not be deducted for a wrong answer.

Any rough working should be done in this booklet.

A copy of the Periodic Table is printed on page 20.

This document consists of **19** printed pages and **1** blank page.

- 1 Petrol spilled on to the ground on a hot day evaporates quickly.

Which diagrams show the change in arrangement of the particles in the petrol?

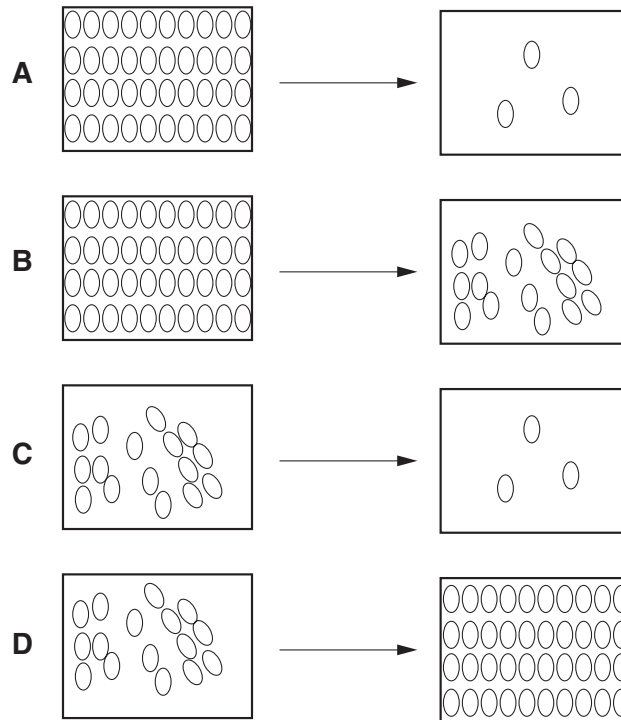

- 2 Hydrogen, nitrogen and oxygen are placed in the gas jars as shown.

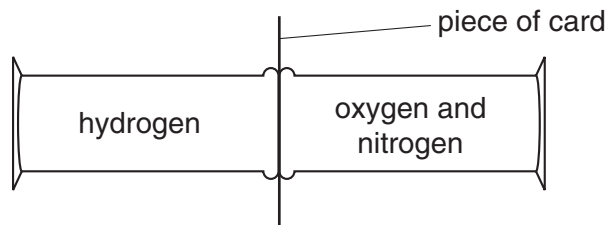

The pressure in each jar is the same.

The piece of card is removed.

In which directions does diffusion occur?

	hydrogen into nitrogen and oxygen	nitrogen into hydrogen	oxygen into hydrogen
A	✓	✓	✓
B	✓	✓	✗
C	✓	✗	✓
D	✗	✓	✓

- 3 Two solids, **X** and **Y**, are mixed together.

The table gives information about each solid.

property	X	Y
coloured	✓	✓
soluble in ethanol	✓	✓

Which methods separate **X** and **Y**?

	add ethanol then use chromatography	add ethanol then filter
A	✓	✓
B	✓	✗
C	✗	✓
D	✗	✗

- 4 The diagram shows a use of an unreactive gaseous element **X** in a light bulb.

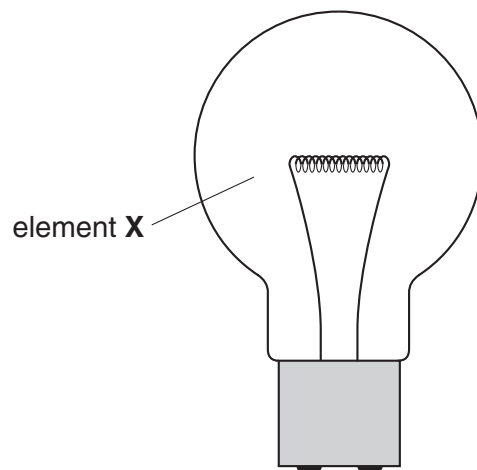

How many electrons are in the outer shell of an atom of **X**?

- A** 1 **B** 6 **C** 7 **D** 8

5 Which two diagrams show two different types of **atom** of the same element?

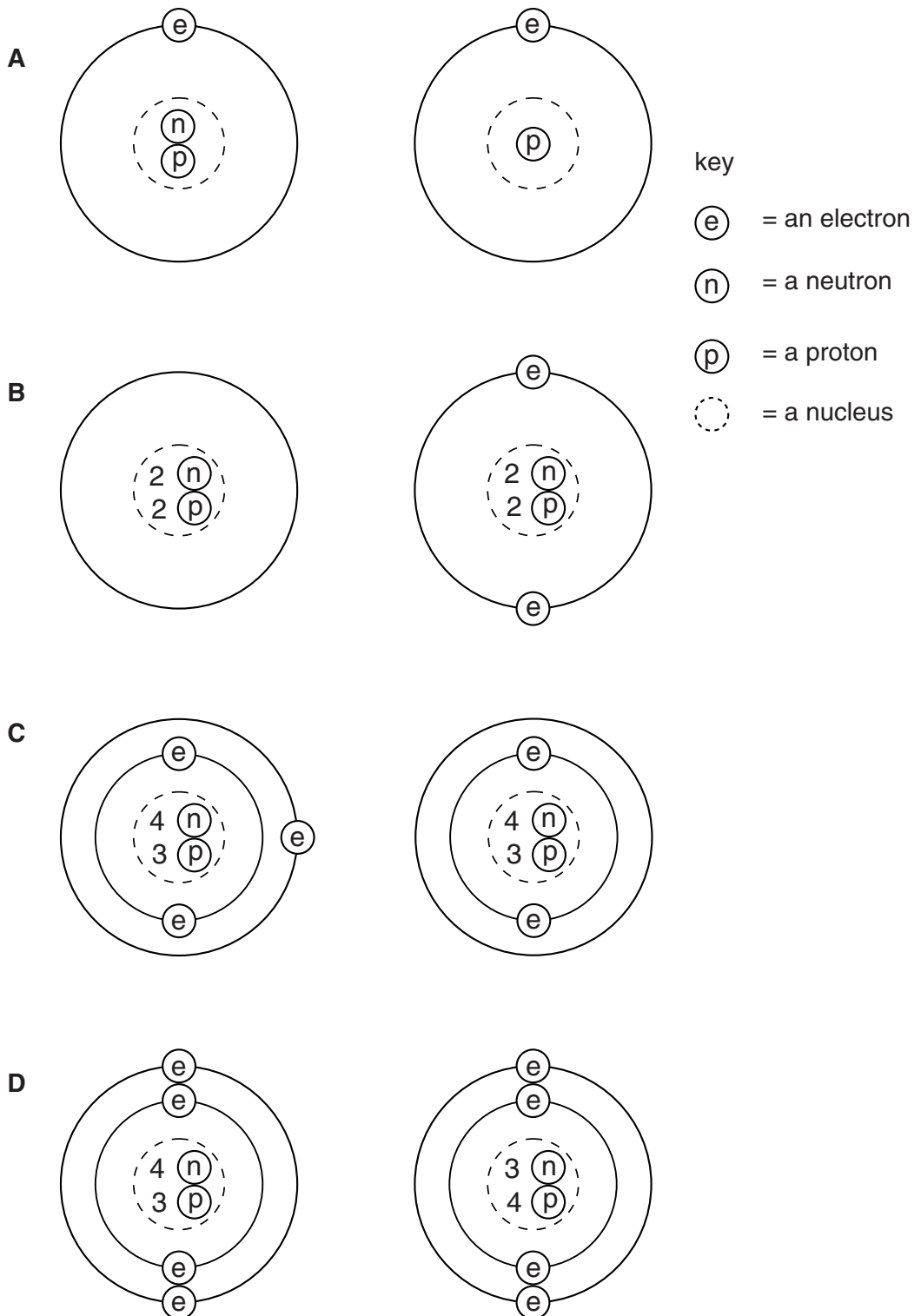

6 The diagram shows the structure of a substance.

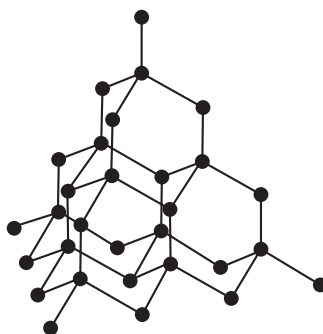

What is represented?

- A diamond
- B graphite
- C methane
- D poly(ethene)

7 The diagrams show models of covalent molecules.

In which diagram is a compound present?

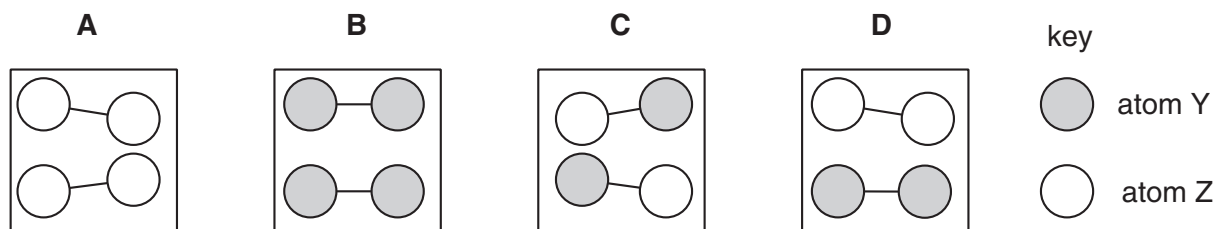

8 Benzoic acid has the molecular formula $C_7H_6O_2$.

The table shows the relative atomic masses of the elements of benzoic acid.

element	relative atomic mass
hydrogen	1
carbon	12
oxygen	16

What is the relative molecular mass of benzoic acid?

- A** 15
- B** 29
- C** 92
- D** 122

- 9 Hydrogen, methane and uranium-235 are energy sources.

Which of these have to be burned to produce energy?

	hydrogen	methane	uranium-235
A	✓	✓	✓
B	✓	✓	✗
C	✓	✗	✓
D	✗	✓	✓

- 10 The equations shown describe chemical reactions involving oxidation and reduction.

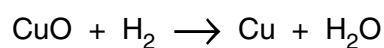
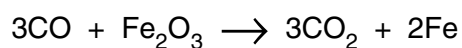

Which substances are the reducing agents?

- A** CO, CuO
B CO, H₂
C CO₂, H₂O
D Cu, Fe
- 11 Dilute hydrochloric acid is added to limestone chips as shown in the diagram.

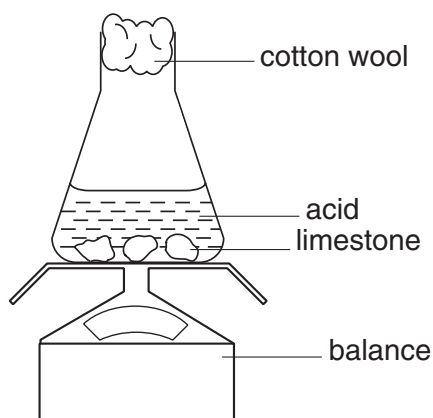

Why does the balance reading **decrease** as the reaction takes place?

- A** The cotton wool acts as a filter.
B The marble dissolves in the acid.
C The reaction is exothermic.
D The reaction produces a gas.

12 The chart shows colours of Universal Indicator at different pH values.

colour	red	yellow	green	blue	violet
pH	1, 2, 3	4, 5, 6	7, 8, 9	10, 11, 12	13, 14

Lemon juice contains citric acid which is only slightly acidic.

What colour would lemon juice give with Universal Indicator?

- A blue
- B green
- C yellow
- D red

13 What are the properties of magnesium and its oxide?

	magnesium is a metal	magnesium burns readily in oxygen	magnesium oxide is
A	✓	✓	basic
B	✓	✓	acidic
C	✓	X	acidic
D	X	✓	basic

14 Element X forms diatomic molecules.

In which group of the Periodic Table is X placed?

- A Group 0
- B Group I
- C Group II
- D Group VII

15 Three mixtures are made.

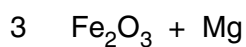
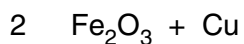
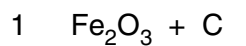

The mixtures are heated strongly.

In which mixtures is iron formed?

- A 1 only
- B 1 and 3 only
- C 2 and 3 only
- D 1, 2 and 3

16 Which metal reacts most quickly with water?

- A calcium
- B copper
- C iron
- D potassium

17 Four metals are shown in order of their reactivity.

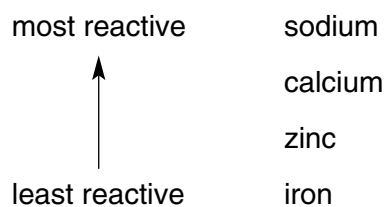

Which metal is extracted from its ore by electrolysis and which by heating its ore with carbon?

	electrolysis	heating with carbon
A	calcium	sodium
B	iron	zinc
C	sodium	iron
D	zinc	calcium

18 What is zinc used for?

	galvanising iron	making brass
A	✓	✓
B	✓	✗
C	✗	✓
D	✗	✗

19 Which of hydrogen and steam can react with ethene?

	hydrogen	steam
A	✓	✓
B	✓	✗
C	✗	✓
D	✗	✗

20 The diagrams show the structures of three compounds.

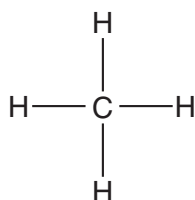

P

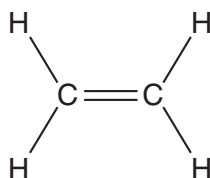

Q

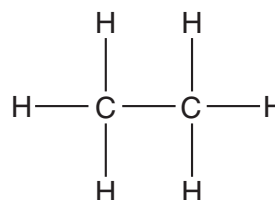

R

Which compounds belong to the same homologous series?

- A** P and Q only
- B** P and R only
- C** Q and R only
- D** P, Q and R

- 21 Which of the following is **not** necessary when using a measuring cylinder to measure the volume of a quantity of water?
- A making sure that the measuring cylinder is vertical
 - B making sure that your eye is level with the liquid surface
 - C reading the bottom of the meniscus
 - D using the largest measuring cylinder possible
- 22 Five telegraph poles are positioned at equal distances along the side of a road.

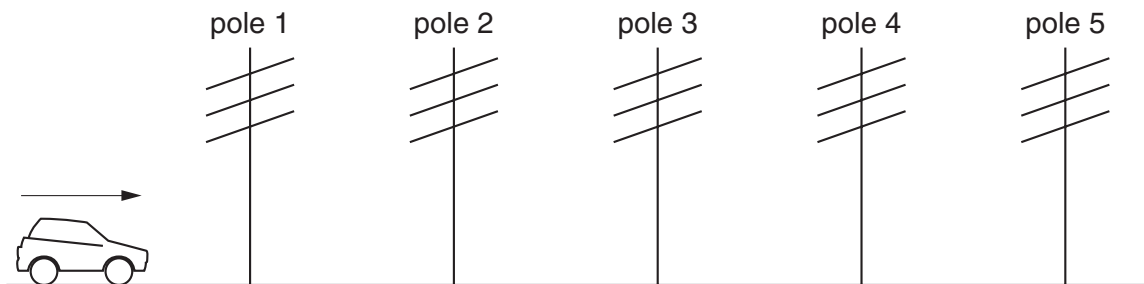

A car accelerates until it is level with pole 4. The car then continues along the road at a steady speed. The times taken to travel between one pole and the next are measured.

Which time is the greatest?

The time between

- A pole 1 and pole 2.
- B pole 2 and pole 3.
- C pole 3 and pole 4.
- D pole 4 and pole 5.

- 23 A train travels along a track from Aytown to Beetown. The map shows the route.

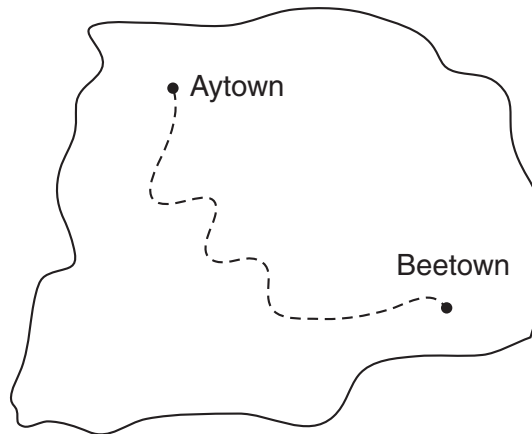

The distance travelled by the train between the towns is 210 km. It moves at an average speed of 70 km/h.

How long does the journey take?

- A less than $\frac{70}{210}$ hours, because the journey is not in a straight line
- B exactly $\frac{70}{210}$ hours
- C exactly $\frac{210}{70}$ hours
- D more than $\frac{210}{70}$ hours, because the journey is not in a straight line
- 24 A student tries to find the density of a metal block. First he measures the weight with a forcemeter (spring balance). Next he measures the sides of the block using a rule, in order to calculate the volume of the block. Finally he divides the weight by the volume to find the density.

The student has made a mistake.

Why does his method **not** give the density?

- A Density is volume divided by weight.
- B He should have measured the surface area, not the volume.
- C He should have used the mass in his calculation, not the weight.
- D Weight is not measured with a forcemeter (spring balance).

25 A large electric motor is used to lift a container off a ship.

Which of the following values are enough to allow the power of the motor to be calculated?

- A the mass of the container and the distance moved
- B the force used and the distance moved
- C the current used and the work done
- D the work done and the time taken

26 A tidal power station is made by building a barrage across the mouth of a river. At high tide the sea water is trapped behind the barrage.

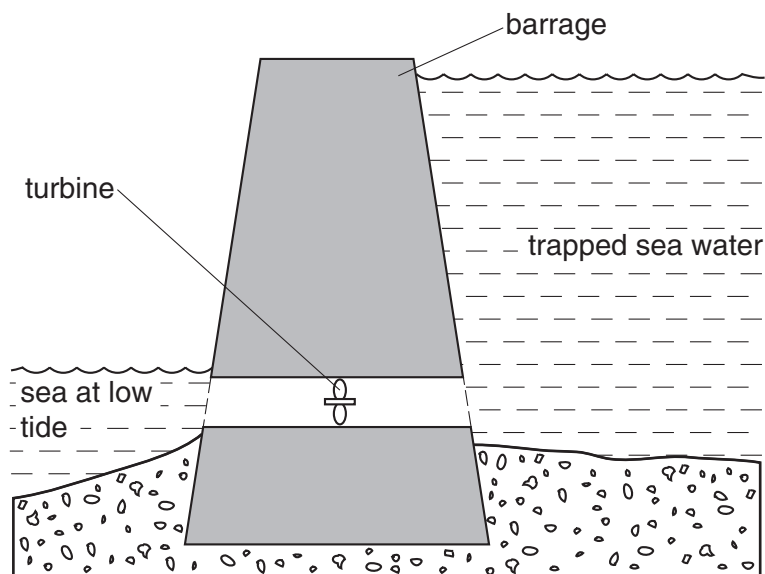

At low tide the water is allowed to flow back into the sea through a turbine.

What is the useful energy change in a tidal power station?

- A electrical energy \rightarrow energy of position (potential)
- B electrical energy \rightarrow energy of motion (kinetic)
- C energy of motion (kinetic) \rightarrow energy of position (potential)
- D energy of position (potential) \rightarrow electrical energy

27 There is a vacuum between the double walls of a vacuum flask.

Which types of heat transfer are reduced by the vacuum?

- A conduction and convection
- B conduction and radiation
- C convection and radiation
- D conduction, convection and radiation

28 The diagrams show four identical pieces of ice that are heated in test-tubes of water.

In which test-tube will the ice take the longest time to melt?

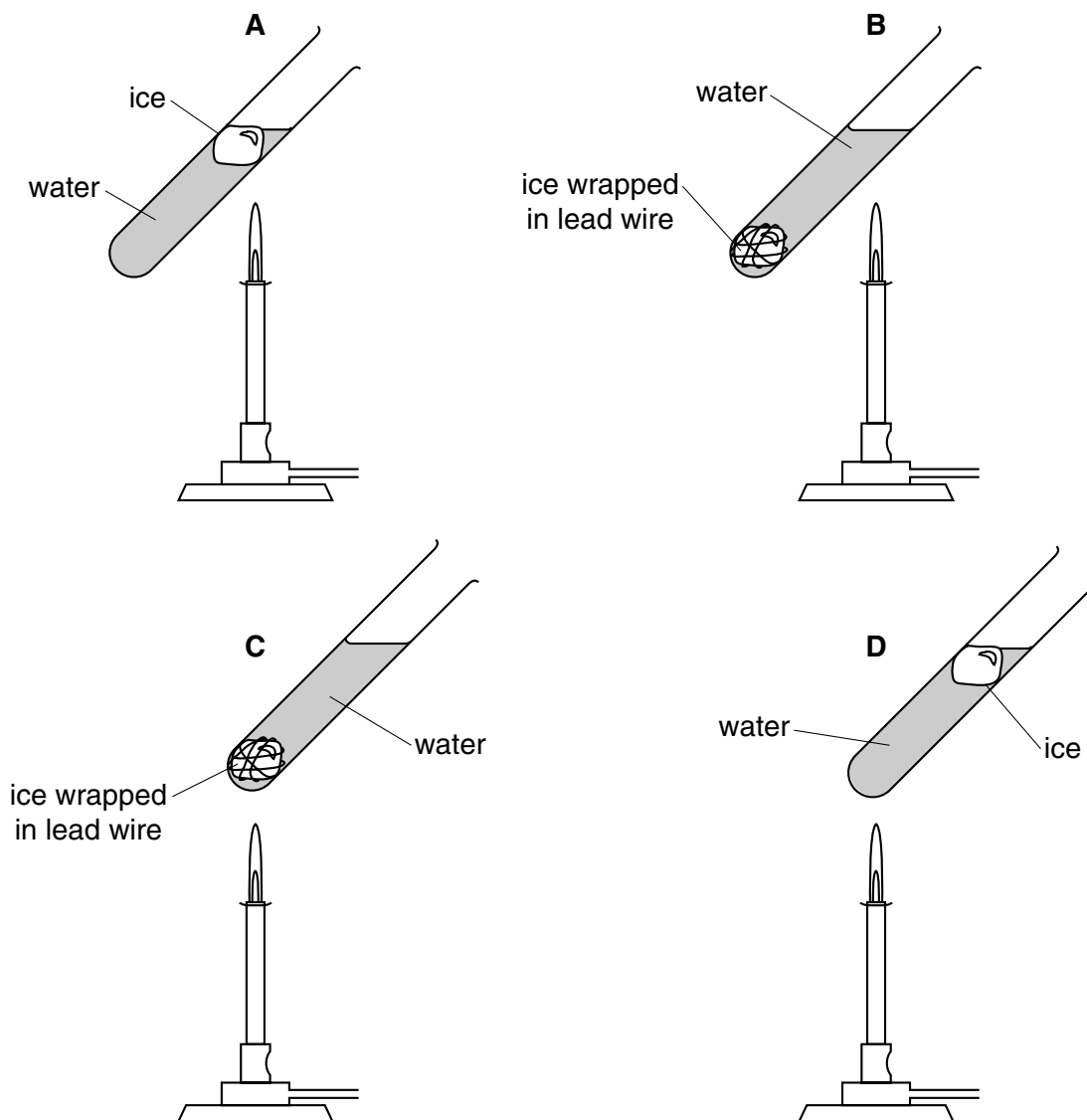

29 Waves travel more slowly on the surface of water when the water is shallow.

A person drops a stone into a pool at **X**. The diagram shows the first wavefront on the surface of the pool.

Which region of the pool is likely to be most shallow?

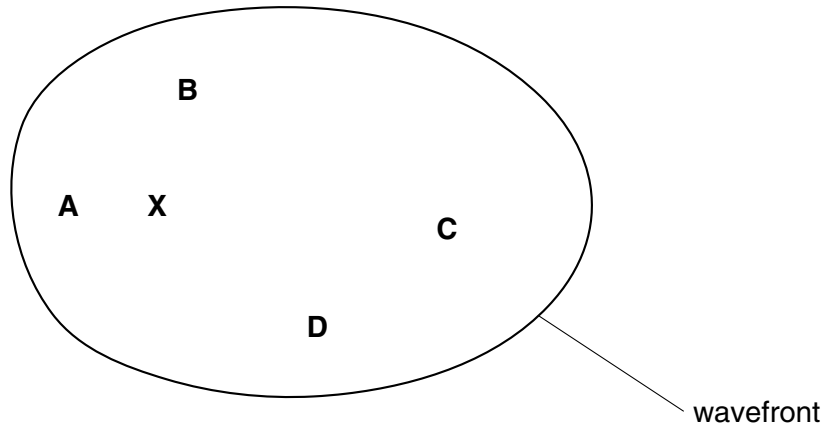

30 Which diagram shows the correct order of the waves in the electromagnetic spectrum?

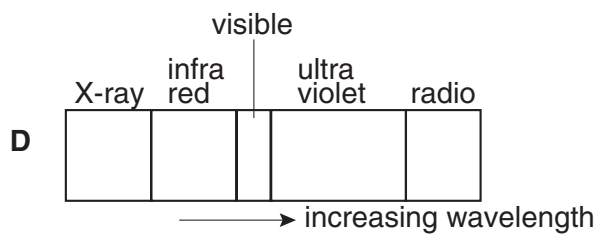
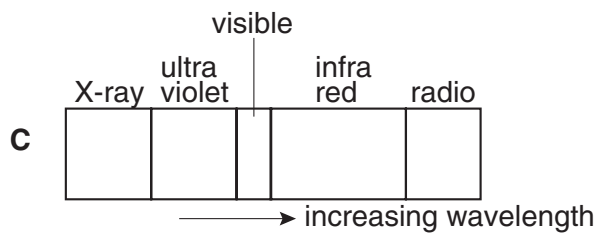
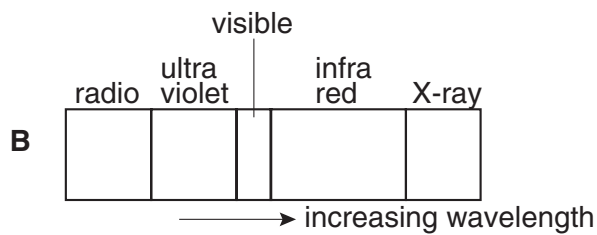
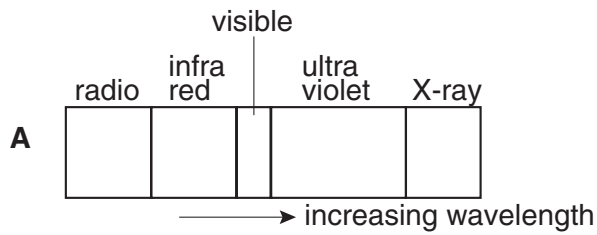

31 Astronaut 1 uses a hammer to mend a satellite in space. Astronaut 2 is nearby. There is no atmosphere in space.

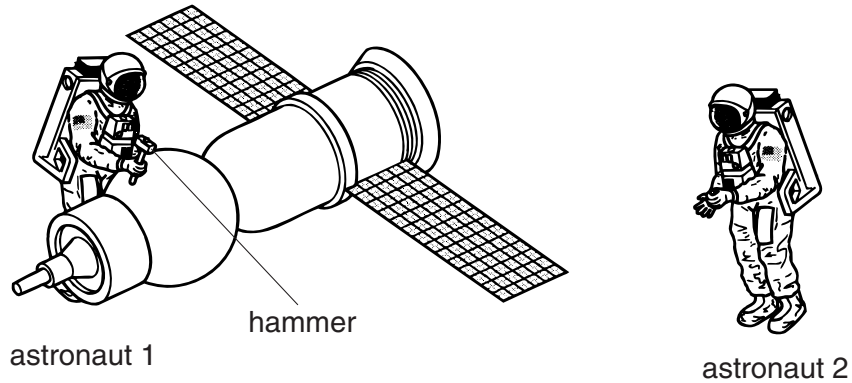

Compared with the sound heard if they were working on Earth, what does astronaut 2 hear?

- A no sound at all
- B a quieter sound
- C a sound of the same loudness
- D a louder sound

32 A steel ball on a horizontal wooden table rolls near the north pole of a bar magnet that is lying on the table.

Which diagram shows the most likely path of the ball, as seen from above the table?

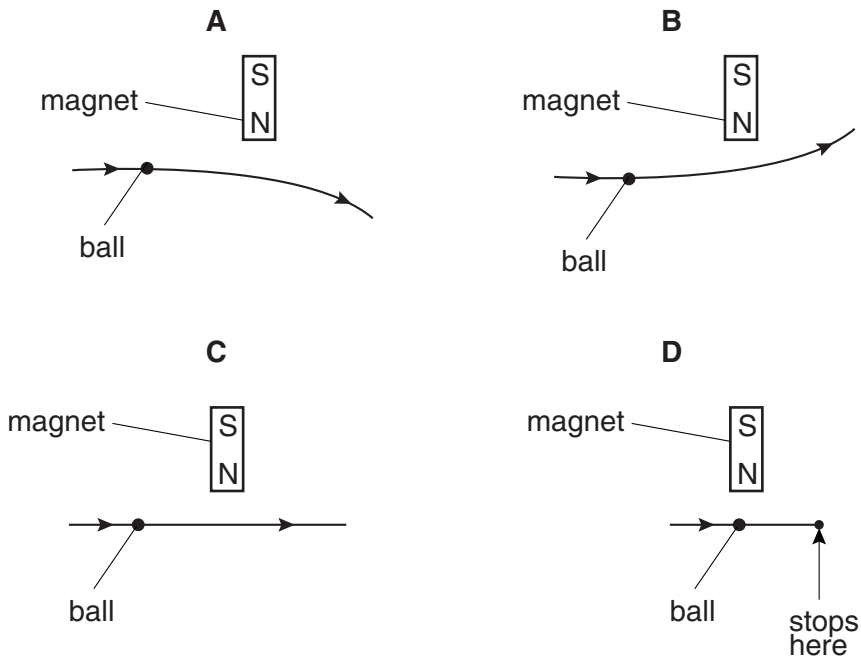

33 A student wants to find the resistance of resistor R using a voltmeter and an ammeter.

Which circuit should the student use?

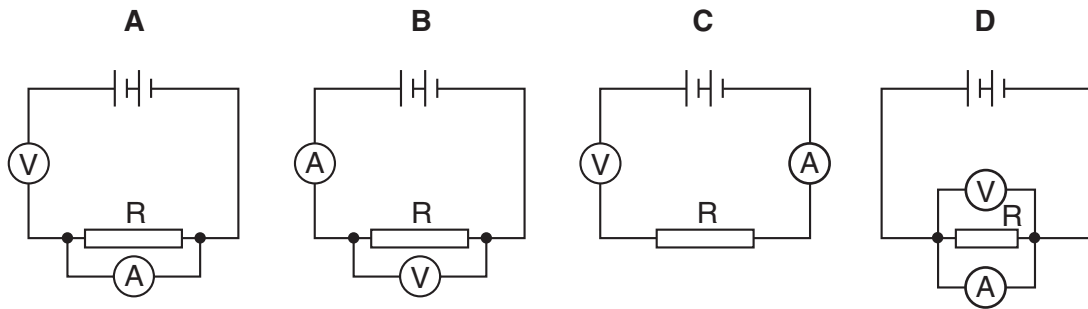

34 Two very light, charged balls P and Q are hung, one above the other, from nylon threads. When a negatively charged plastic sheet is placed alongside them, P is repelled and Q is attracted.

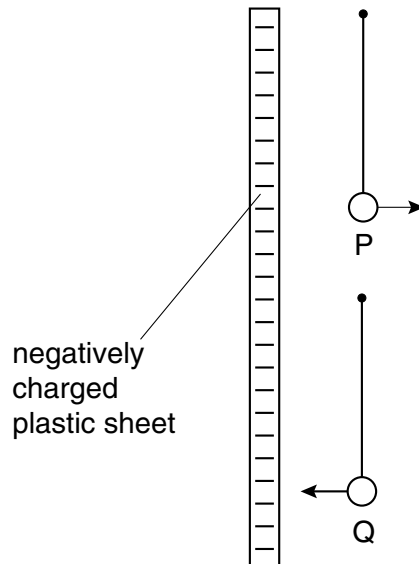

What are the original charges on P and on Q?

	charge on P	charge on Q
A	negative	negative
B	negative	positive
C	positive	negative
D	positive	positive

- 35 Four students are asked to draw a circuit showing three lamps working in parallel, a cell, and a switch that controls all three lamps.

Which student is correct?

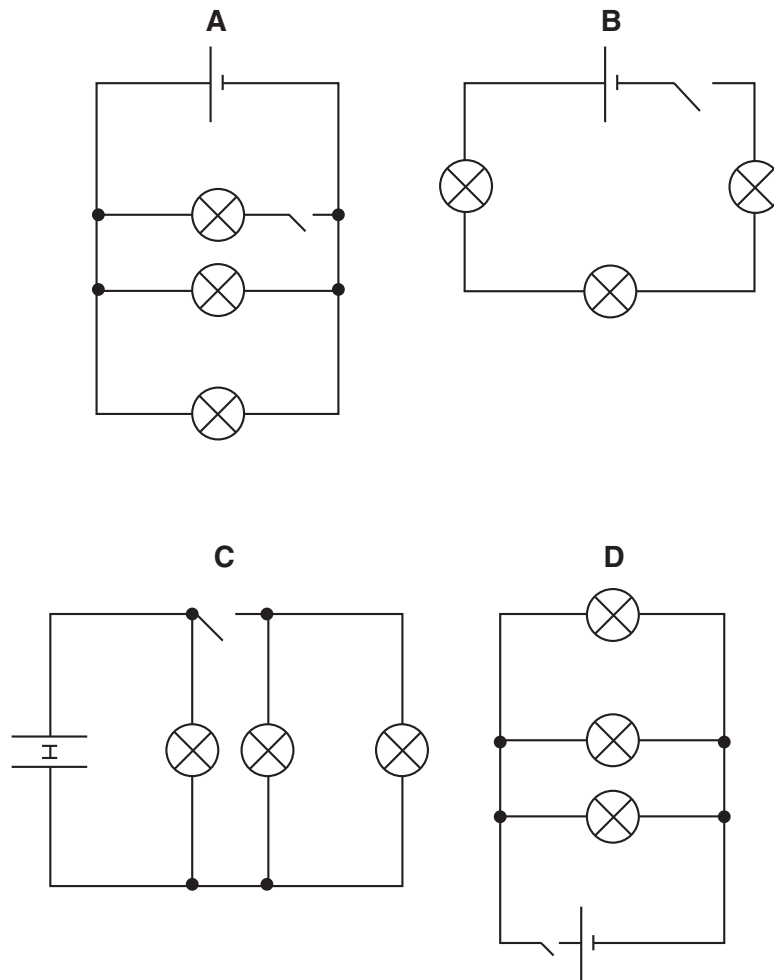

- 36 A $3.0\ \Omega$ lamp and a $6.0\ \Omega$ lamp are connected in series.

What is the total resistance of the combination?

- A $0.5\ \Omega$
- B $2.0\ \Omega$
- C $9.0\ \Omega$
- D $18.0\ \Omega$

37 In a cathode-ray tube, particles are given off from a hot cathode by thermionic emission.

Which particles are given off?

- A atoms
- B electrons
- C ions
- D protons

38 Which line in the table describes the nature of an α -particle and a γ -ray?

	α -particle	γ -ray
A	helium nucleus	electromagnetic radiation
B	helium nucleus	electron
C	proton	electromagnetic radiation
D	proton	electron

39 A radioactive nucleus R decays with the emission of a β -particle as shown.

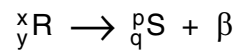

Which equation is correct?

- A $x = p$
- B $y = q$
- C $p = x - 1$
- D $q = y - 1$

40 Which line in the table shows the structure of the nucleus of a helium atom ${}^4_2\text{He}$?

	electrons	neutrons	protons
A	2	2	0
B	2	0	2
C	0	2	2
D	2	2	2

