

Centre Number	Candidate Number	Name
---------------	------------------	------

UNIVERSITY OF CAMBRIDGE INTERNATIONAL EXAMINATIONS
International General Certificate of Secondary Education

PHYSICAL SCIENCE **0652/06**

Paper 6 Alternative to Practical May/June 2004

1 hour

Candidates answer on the Question Paper.
No Additional Materials are required.

READ THESE INSTRUCTIONS FIRST

Write your Centre number, candidate number and name on all the work you hand in.
Write in dark blue or black pen in the spaces provided on the Question Paper.
You may use a soft pencil for any diagrams, graphs or rough working.
Do not use staples, paper clips, highlighters, glue or correction fluid.

Answer **all** questions.
The number of marks is given in brackets [] at the end of each question or part question.

If you have been given a label, look at the details. If any details are incorrect or missing, please fill in your correct details in the space given at the top of this page.

Stick your personal label here, if provided.

For Examiner's Use	
1	
2	
3	
4	
5	
6	
Total	

- 1 A student investigated how much a wooden beam bent when different loads were placed near the end of the beam.

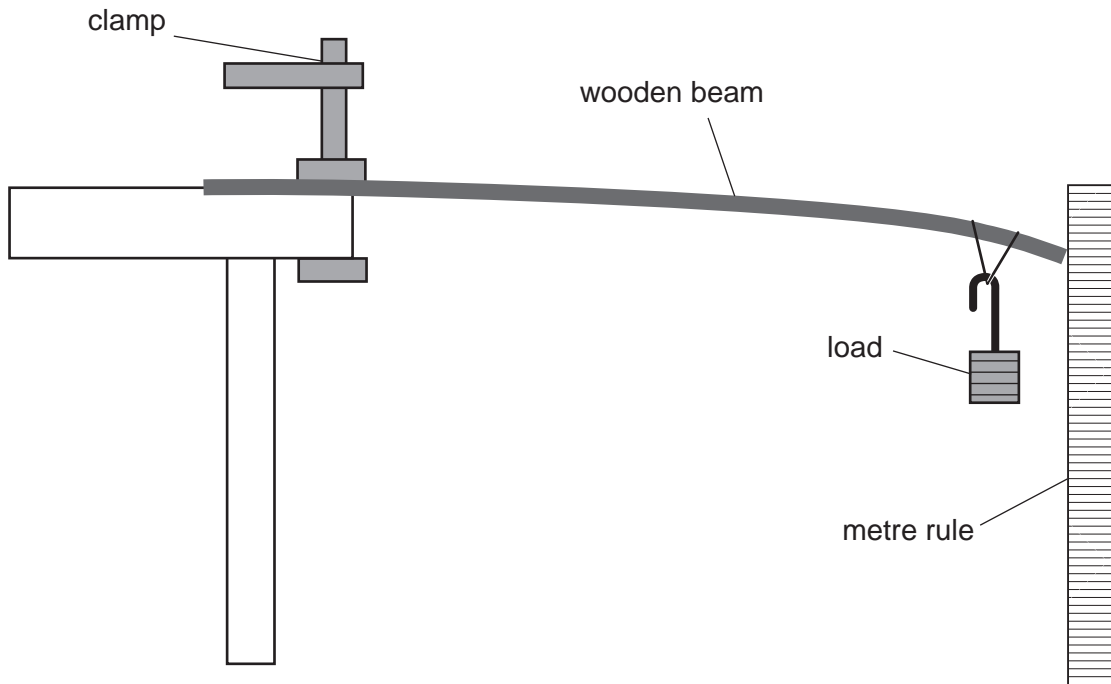

Fig. 1.1

She set up the apparatus shown in Fig. 1.1. The metre rule was positioned so that, with no load on the beam, the top of the beam was level with the 0 cm mark.

The student added a 100 g load to the end of the beam and recorded the displacement of the beam using the metre rule. She added further 100 g loads, recording the displacement of the beam, until the total load was 500 g. She recorded her results in a table, Fig. 1.2.

load / g	displacement / cm
0	0
100	
200	
300	10.0
400	15.5
500	22.0

Fig. 1.2

- (a) The measurements of the bend of the beam, for 100 g and 200 g are shown in Fig. 1.3. Record these measurements, from the top of the beam, in Fig. 1.2. [2]

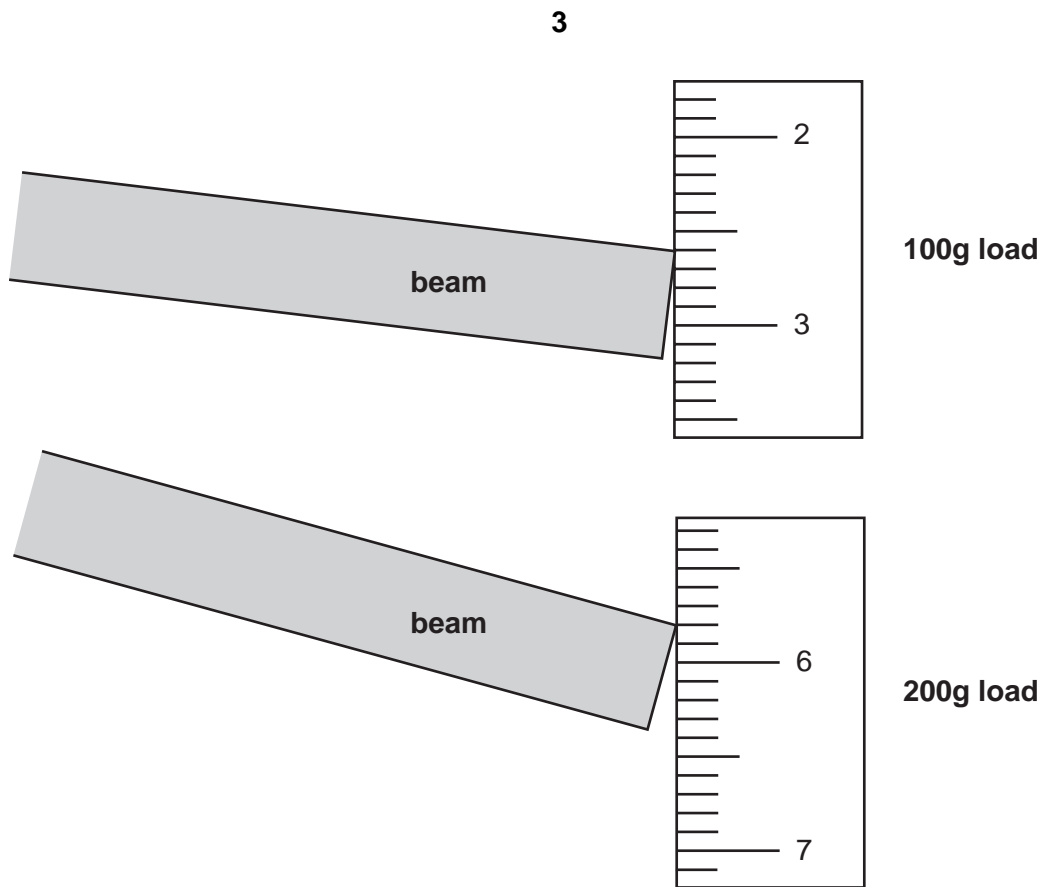

Fig. 1.3

- (b)** What relationship is there between the load and the displacement of the beam?
.....[1]
- (c)** How could the student improve the accuracy of her results?
.....[1]
- (d) (i)** How would the results be affected if the beam was thicker? Explain your answer.
.....
.....[1]
- (ii)** How would the results be affected if the beam was shorter? Explain your answer.
.....
.....[1]

- 2 A student investigated how the current passing through a light bulb was affected by changing the applied voltage. Fig. 2.1 shows the circuit that he used.

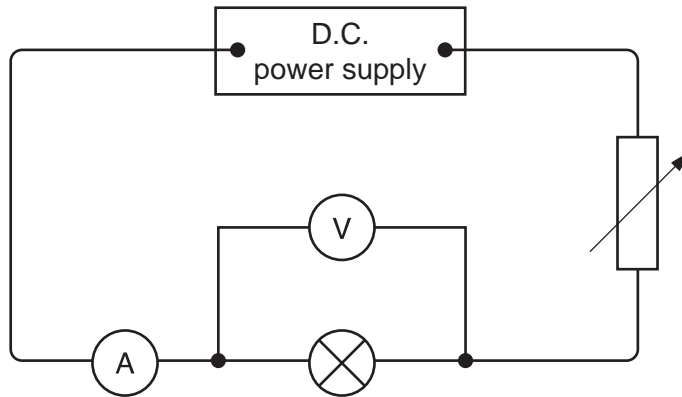

Fig. 2.1

- He set the variable resistor to the highest value.
- He wrote down the readings of the milliammeter and voltmeter in Fig. 2.2.
- He decreased the resistance of the variable resistor and then read the milliammeter and voltmeter again, repeating this several times.
- He plotted a graph of voltage against current, Fig. 2.4.

voltage/volts	current/milliamps
0.5	35
1.1	80
2.0	170
2.5	280

Fig. 2.2

- (a) Fig. 2.3 shows the voltmeter and milliammeter for the two missing sets of readings. Read the meters and complete Fig. 2.2. [3]

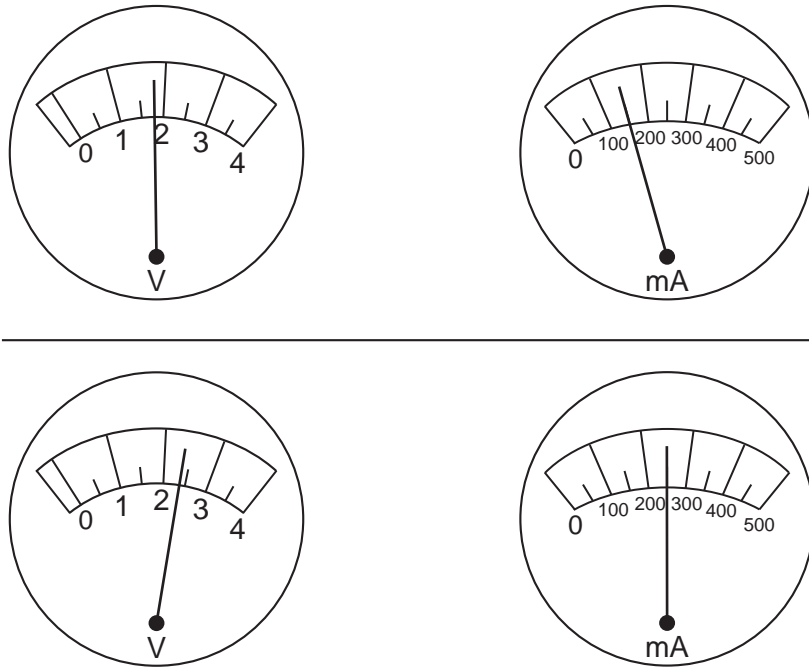

Fig. 2.3

- (b) Fig. 2.4 shows the graph grid with some of the points already plotted. Plot your readings from (a), and draw a suitable line through the points. [3]

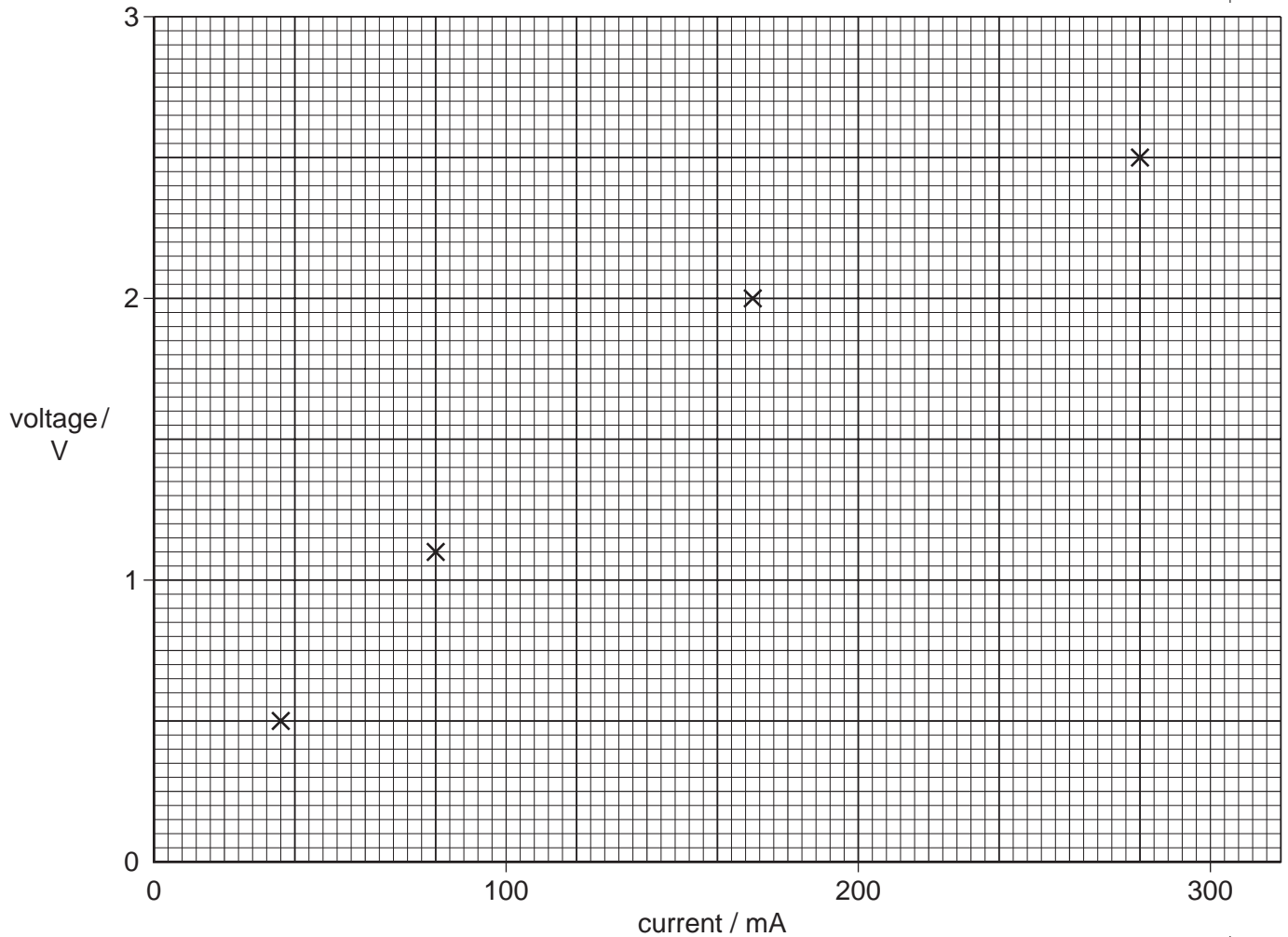

Fig. 2.4

- (c) (i) Explain how the brightness of the bulb changed as the resistance of the variable resistor was decreased.

.....
[1]

- (ii) Explain why the current might suddenly drop to zero above a certain applied voltage.

.....[1]

- (d) Did the light bulb obey Ohm's Law? Explain your answer.

.....[1]

3 A student made a sample of copper(II) nitrate, a blue crystalline salt.

- He weighed out a sample of copper into a beaker. He placed the beaker in a fume cupboard and then added some concentrated nitric acid. A poisonous acidic gas was given off. When the reaction had finished, some copper remained in the beaker.
- He separated the excess copper from the solution.
- Then he obtained copper(II) nitrate crystals from the solution.

(a) Fig. 3.1 shows the balance windows for weighing the copper.

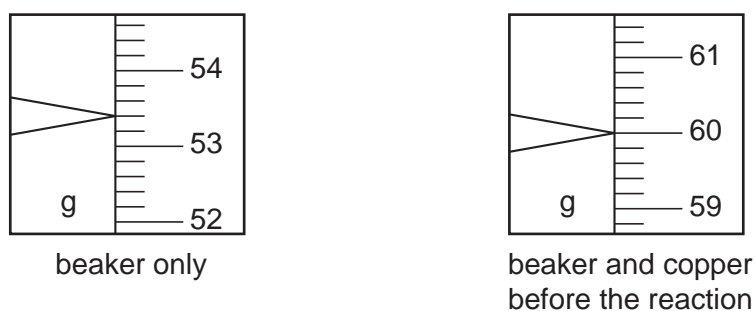

Fig. 3.1

(i) Record the balance readings in the spaces below.

mass of beaker only = g

mass of beaker and copper = g

(ii) Calculate the mass of copper in the beaker.

mass of copper in the beaker = g [3]

(b) Carefully explain how the student can show that the gas given off during the reaction between copper and nitric acid is acidic.

.....
[1]

- (c) The student washed, dried and weighed the excess copper in the beaker. Fig. 3.2 shows the balance reading for the beaker and the excess copper left after the reaction.

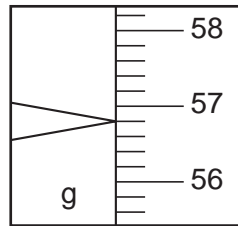

beaker and copper left over
after the reaction

Fig. 3.2

- (i) Record the reading in the space below.

mass of beaker and excess copper = g

- (ii) Calculate the mass of copper that was used up in the reaction with the nitric acid.

mass of copper that reacted with the nitric acid = g [1]

- (d) Copper(II) nitrate forms blue crystals that decompose if they are heated. Carefully explain how the student could obtain copper(II) nitrate crystals from the solution.

.....

 [2]

- (e) The student collected and weighed the crystals in the same beaker that he used before. Fig. 3.3 shows the balance reading.

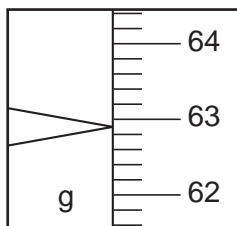

beaker and copper nitrate crystals

Fig. 3.3

- (i) Record the reading in the space below.

mass of beaker and copper(II) nitrate crystals = g

- (ii) Calculate the mass of copper (II) nitrate crystals.

mass of copper(II) nitrate crystals = g [2]

- (f) The teacher said that the mass of copper dissolved by the acid would make 12.1 g of hydrated copper(II) nitrate. Suggest **one** reason why the student did not get as much copper(II) nitrate crystals as this.

.....

.....[1]

4 A student investigated the relative densities of five gases, **A**, **B**, **C**, **D** and **E**. She used five identical balloons.

- She filled one balloon with gas **A**.
- She then held the balloon at the point exactly half way between the floor and the ceiling, in a room that was exactly 4 metres in height.
- She let the balloon go and found the time that it took to rise to the ceiling or to fall to the floor.
- She repeated this with the other gases, filling each balloon with gas until the volume was the same each time.

Fig. 4.2 shows two of the times. The student also recorded whether the balloon fell to the floor or rose to the ceiling. The times for the other three balloons are shown on the stopclocks in Fig. 4.1.

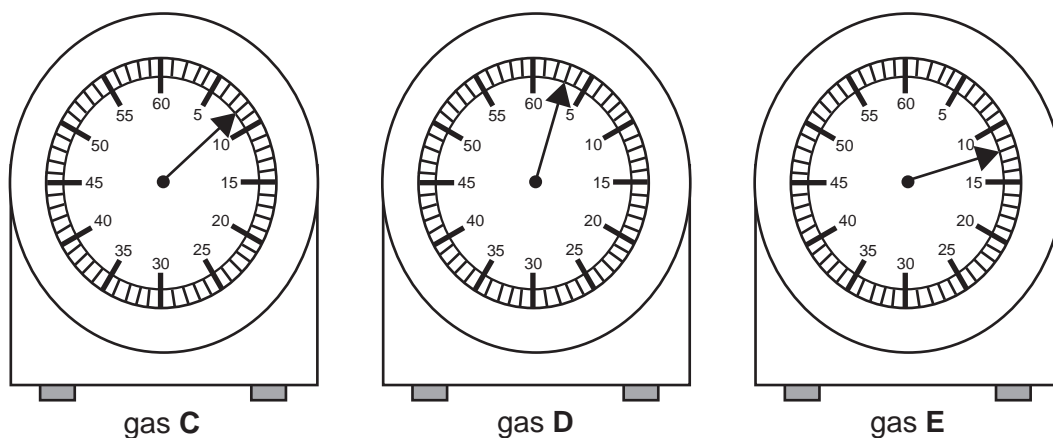

Fig. 4.1

(a) Record the times in Fig. 4.2.

gas	time / s	rise or fall
A	2	rise
B	9	rise
C		fall
D		rise
E		fall

Fig. 4.2

[3]

(b) Which of the five gases had the greatest density? Explain your answer.

.....
.....
.....[1]

(c) Why did some of the gases rise and some of them fall?

.....
.....[2]

(d) Why was it important that the volume of each balloon was the same each time?

.....
.....[1]

(e) (i) Another student suggested that gas **A** could be hydrogen. What data from the experiment supports this?

.....
.....[1]

(ii) What test can the student do to confirm that the gas was hydrogen and what is the result of this test?

test

result[2]

- 5 Tests were carried out on two white crystalline solids, **A** and **B**. Fig. 5.1 shows the observations and the conclusions of some of the tests.

(a) Complete the table, Fig. 5.1.

test	observations	conclusions
1. A portion of solid A was strongly heated. The gas given off was tested with limewater.	<i>The limewater changed from</i> <i>to</i>	[1] [1]
2. A portion of solid B was strongly heated. The gas given off was tested with (a) a lighted splint (b) limewater	<i>the flame was extinguished.</i> <i>the limewater changed as it did in test 1.</i>	[1] [1]
3. A portion of solid A was dissolved in water. Universal Indicator was added.	<i>The colour of the Universal Indicator changed from</i> <i>to</i>	<i>Solid A is an acid.</i> [2]
4. A portion of solid B was dissolved in water. Universal Indicator was added to the solution.	<i>The colour of the Universal Indicator changed from</i> <i>to</i>	<i>The pH of the solution of solid B is about 6.</i> [1]

Fig. 5.1

- (b) When solid **A** is mixed with solid **B** and water is added, a gas is given off. Describe how you would measure the volume of this gas. You can answer this question by drawing a labelled diagram in the space below.

[3]

- 6 A student read that an object floats in water when its density is less than that of water.

When the density of the object is just greater than that of water, it will sink. When the mass in g of a vessel placed in water is just greater than its volume in cm^3 , it will sink, since the density of water is equal to 1 g/cm^3 .

The student decided to test this statement by carrying out an experiment using a plastic drinking cup.

- (a) To find the volume of water that the cup would hold, he filled a measuring cylinder up to the 250 cm^3 mark. He poured water from the measuring cylinder into the cup until it was completely full. He did not let any water spill over. Suggest a way of putting the last few drops of water into the cup so that it is full but not spilling over.

.....[1]

(b) Fig. 6.1 shows the scale of the measuring cylinder after the cup was filled.

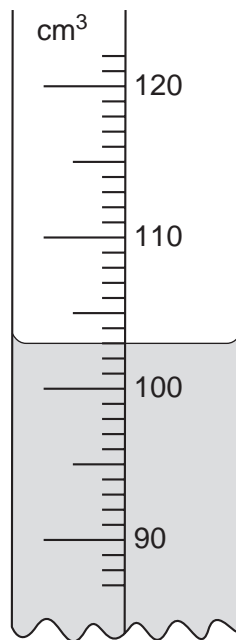

Fig. 6.1

- (i) Record the volume of water left in the 250 cm³ measuring cylinder in the space below.

volume of water left in the measuring cylinder cm³ [1]

- (ii) Calculate the volume of water placed in the cup.

volume of water in the cup cm³ [1]

The student emptied all the water out of the cup, then he placed 50 cm^3 of water into it. He placed the cup into a beaker about half-full of water. See Fig. 6.2.

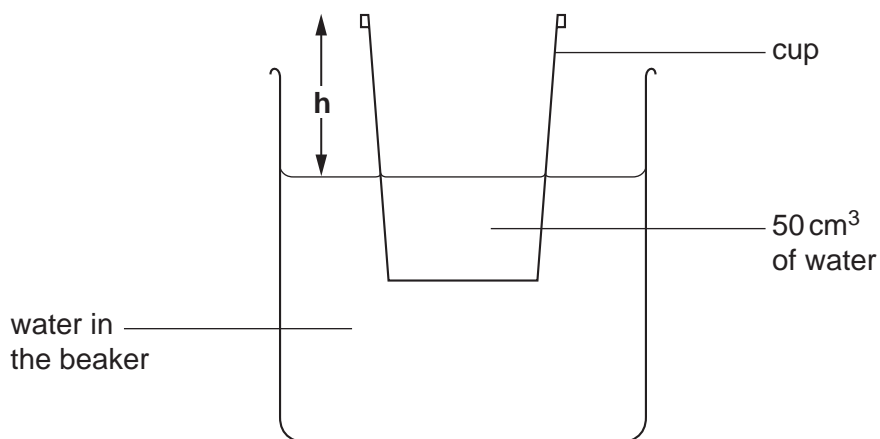

Fig. 6.2

He measured the distance h mm shown in Fig. 6.2, and recorded it in the table, Fig. 6.3.

volume of water in the cup/cm ³	height h / mm
50	36
70	
90	22
110	
130	6

Fig. 6.3

The student put another 20 cm^3 of water into the cup, and measured h again. He repeated this, adding 20 cm^3 of water each time until a total of 130 cm^3 was reached.

- (c) Fig. 6.4 shows the cup floating in the water for two of the boxes in Fig. 6.3. Measure and record the vertical height h each time. [2]

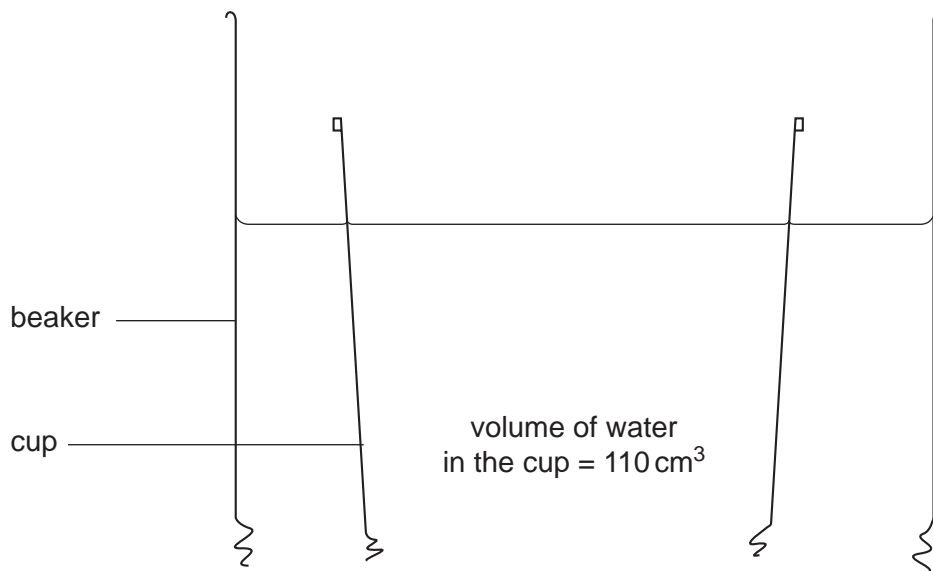
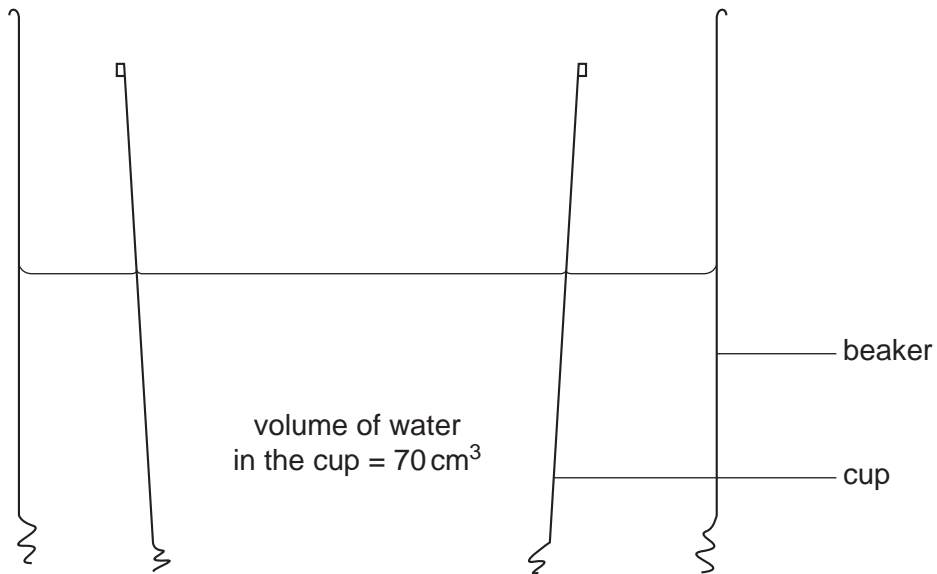
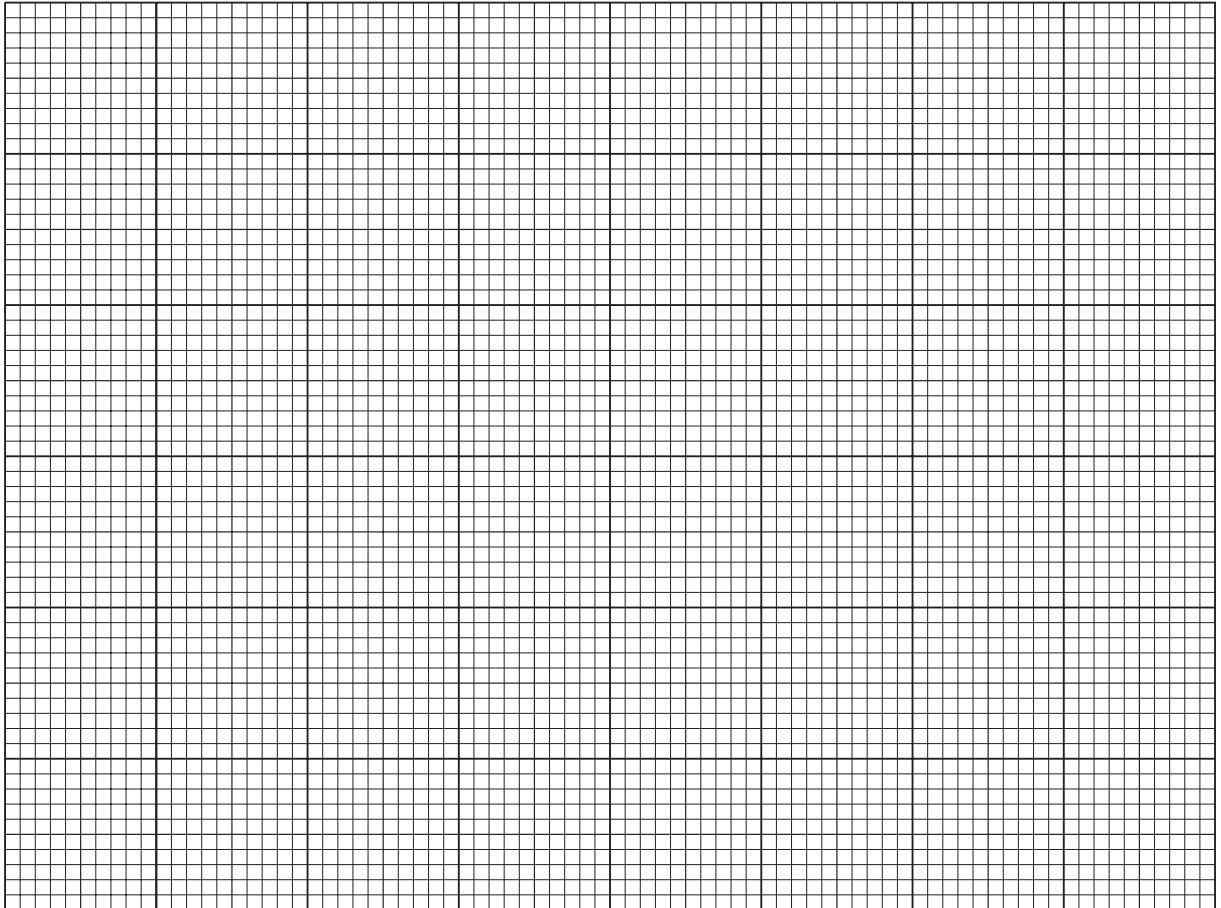

Fig. 6.4

- (d) (i) Plot a graph of **h** (vertical axis) against the volume of water in the cup. Draw the best straight line through your points and extend it to cut the horizontal axis.



[3]

- (ii) Read off from your graph the volume when **h** = 0.

volume =cm³ [1]

- (iii) What will happen to the cup when **h** = 0?

.....[1]

- (e) Did the experiment prove the statement that the student read? Explain your answer.

.....
[1]

