

Centre Number	Candidate Number	Name
---------------	------------------	------

CAMBRIDGE INTERNATIONAL EXAMINATIONS  
International General Certificate of Secondary Education

**PHYSICAL SCIENCE**

**0652/06**

Paper 6 Alternative to Practical

May/June 2003

**1 hour**

Candidates answer on the Question Paper.  
No Additional Materials are required.

**READ THESE INSTRUCTIONS FIRST**

Write your Centre number, candidate number and name on all the work you hand in.  
Write in dark blue or black pen in the spaces provided on the Question Paper.  
You may use a soft pencil for any diagrams, graphs, tables or rough working.  
Do not use staples, paper clips, highlighters, glue or correction fluid.

Answer **all** questions.

At the end of the examination, fasten all your work securely together.

The number of marks is given in brackets [ ] at the end of each question or part question.

For Examiner's Use	
1	
2	
3	
4	
5	
6	
<b>Total</b>	

If you have been given a label, look at the details. If any details are incorrect or missing, please fill in your correct details in the space given at the top of this page.

Stick your personal label here, if provided.

This document consists of **14** printed pages and **2** blank pages.



- 1 A student wanted to find the density of three irregular shaped objects. He used a balance to find the mass of each object. The balance readings are shown in Fig. 1.1.

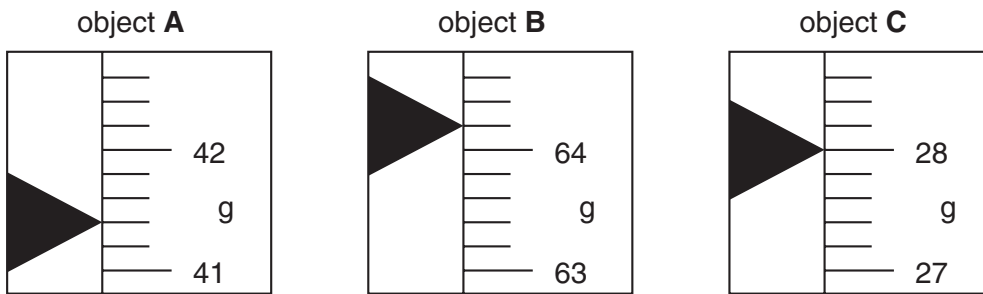

**Fig. 1.1**

- (a) Record these masses in the table, Fig. 1.4. [3]

The student used a Eureka can to find the volume of the three objects. He tied a piece of string around one object and lowered it into a Eureka can full of water. He collected the displaced water in a beaker as shown in Fig. 1.2.

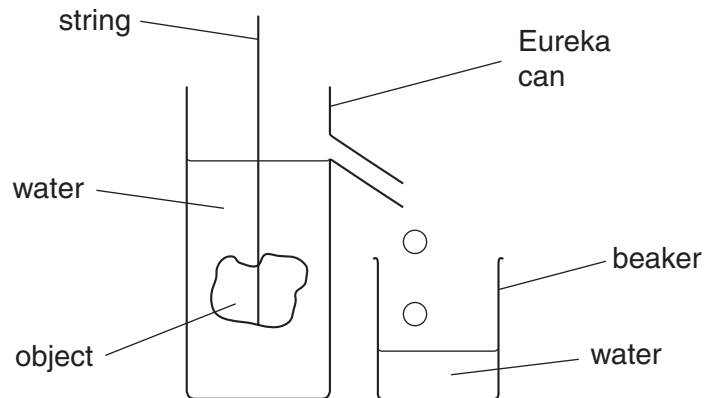

**Fig. 1.2**

The student then poured the water from the beaker into a measuring cylinder and recorded the volume. The readings on the measuring cylinders for the three objects are shown in  $\text{cm}^3$  in Fig. 1.3.

- (b) Record these readings in the table, Fig. 1.4. [3]

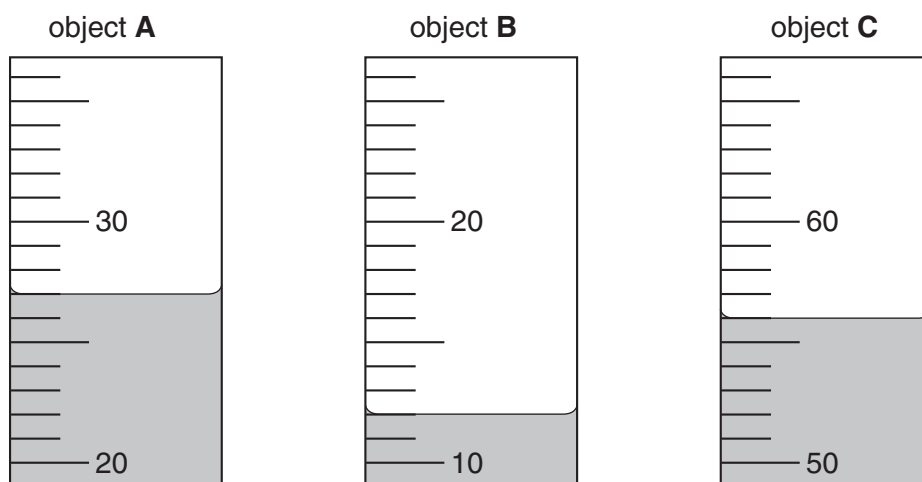

**Fig. 1.3**

object	mass / g	volume / cm <sup>3</sup>
<b>A</b>		
<b>B</b>		
<b>C</b>		

**Fig.1.4**

The density of an object can be calculated using the following formula.

$$\text{density} = \frac{\text{mass}}{\text{volume}}$$

- (d) Calculate the density of object **C** from your recorded values of mass and volume in the table, Fig. 1.4. State the unit for density in your answer.

density of object **C** = ..... unit = ..... [3]

- (d) State whether you think object **C** would float or sink when placed in water. Explain your answer.

.....  
 .....  
 .....[2]

- (e) The student was told by her teacher that the experiment might be more accurate if she allowed the water from the Eureka can to run directly into the measuring cylinder rather than into a beaker first. Explain why.

.....  
 .....[1]

- 2 A student was given one piece of each of the metals copper, magnesium and zinc. She did three experiments to find the potential difference set up between the metals. The apparatus is shown in the diagram, Fig. 2.1.

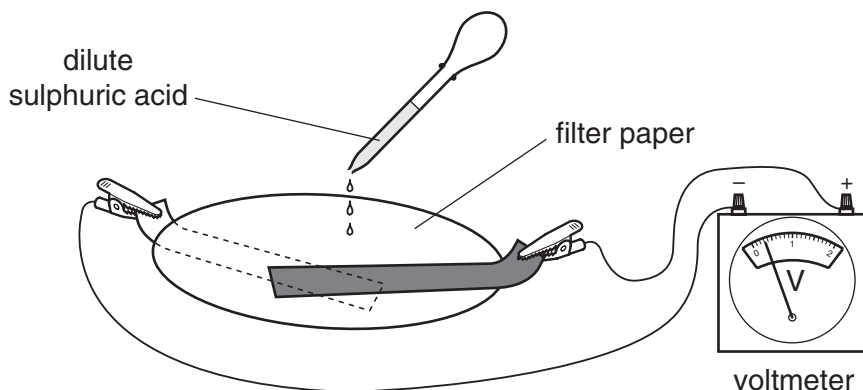

Fig. 2.1

- She connected the metals magnesium and zinc to the voltmeter and placed a filter paper between them (see Fig. 2.1).
- She moistened the filter paper with dilute sulphuric acid.
- She read the voltmeter and noted the result in the table, Fig. 2.3.

- (a) The diagrams of the voltmeter scales, Fig. 2.2, show the potential differences between the other two pairs of metals.

Read the scales and record the results in the table, Fig. 2.3.

[4]

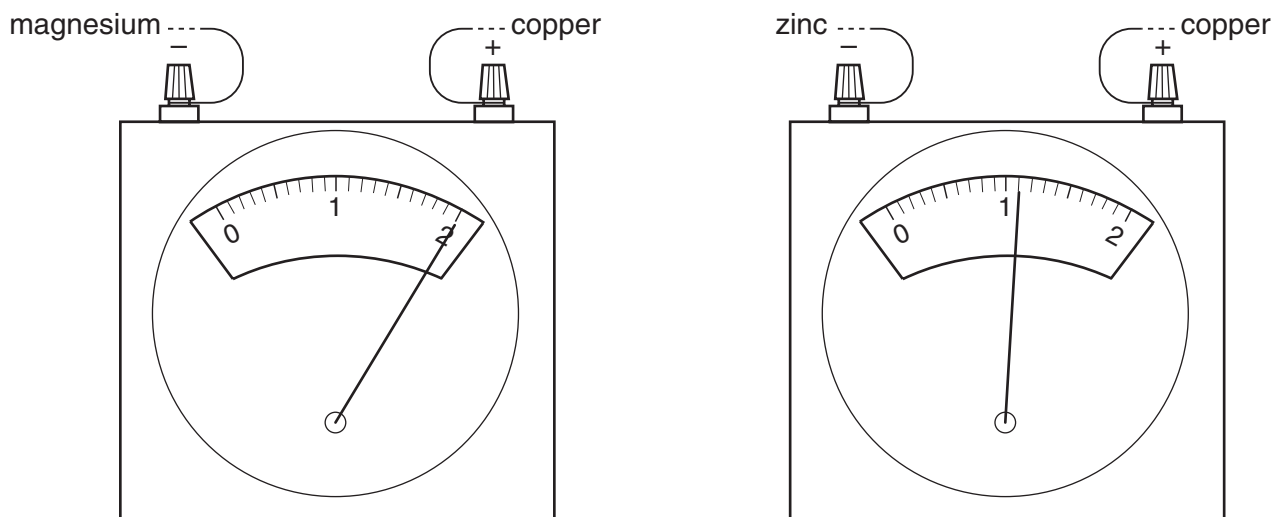

Fig. 2.2

experiment no.	metal connected to the negative terminal (-) of the voltmeter	metal connected to the positive terminal (+) of the voltmeter	potential difference / V
1	magnesium	zinc	1.6
2			
3			

Fig. 2.3

(b) From the results, state which of the three metals is

(i) the most negative, .....

(ii) the most positive. ....

[2]

(c) Place the metals copper, magnesium and zinc in order of their reactivity, most reactive first.

most reactive .....

.....

least reactive .....

[1]

(d) The student was given a piece of another metal, **X**. The teacher did not tell her the name of this metal.

Describe an experiment to find the correct place for metal **X** in the order of reactivity that you have stated in (c).

.....

.....

.....

.....[3]



- 3 A student did an experiment to investigate the relationship between the applied force and the extension of a spring.

He used the apparatus shown in the diagram, Fig. 3.1.

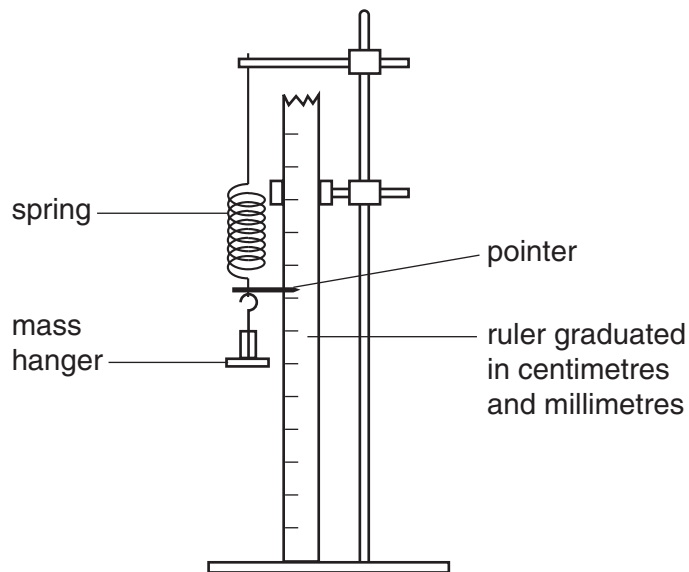

**Fig. 3.1**

The student hung a mass hanger on the spring.

- He read off the height,  $h_0$ , of the pointer above the bench, and recorded it in the table, Fig. 3.3.
- He added a 50 g mass to the mass hanger.
- He found the height,  $h_1$ , of the pointer and recorded it in the table.
- He added more 50 g masses, each time recording the height,  $h$ , until 250 g had been added.

Fig. 3.2 shows the heights of the pointer and the scale of the ruler for the masses 150, 200 and 250 g.

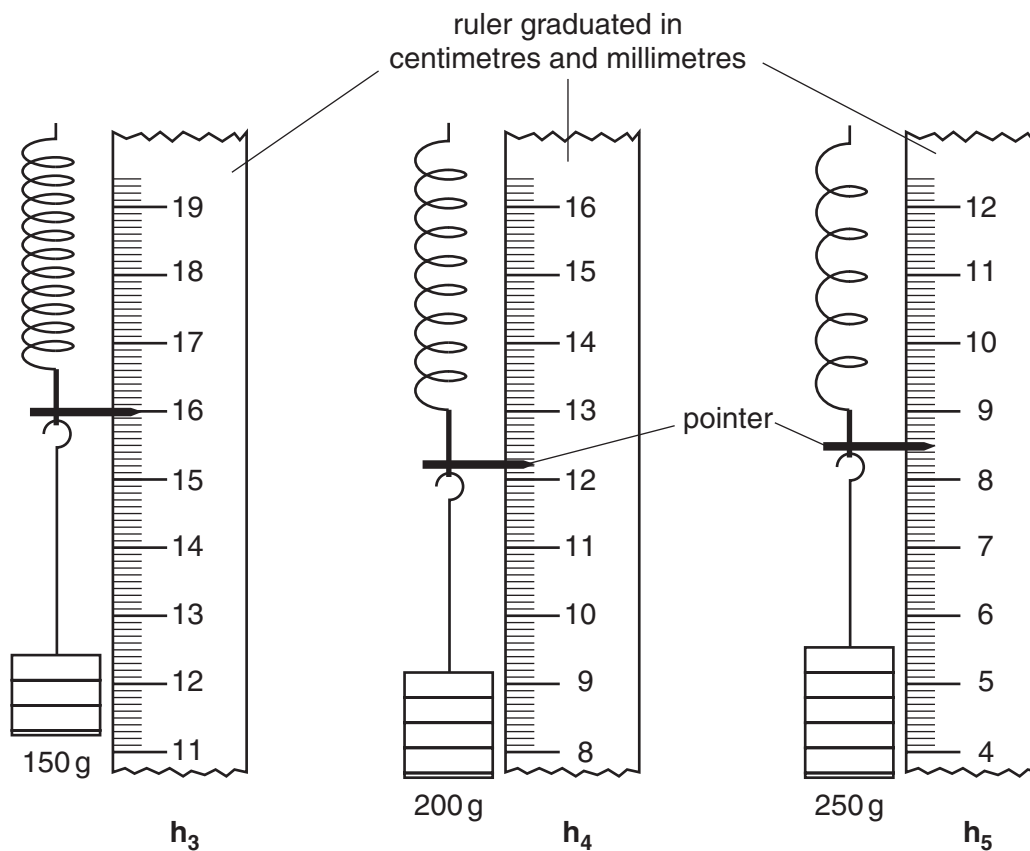

Fig. 3.2

- (a) Read the heights,  $h_3$ ,  $h_4$  and  $h_5$  in Fig. 3.2, to the nearest mm, and record them in the table, Fig. 3.3. [2]
- (b) Complete Fig. 3.3, noting that you are required to convert each mass into a force. ( $1000\text{ g} = 10\text{ N}$ ) Calculate the total increase in length of the spring (the extension) for each mass added. [2]

total mass added / g	force / N	height $h$ / mm	total increase in length (extension) / mm
0	0	$h_0 = 270$	0
50	0.5	$h_1 = 233$	37
100	1.0	$h_2 = 195$	75
150		$h_3 =$	
200		$h_4 =$	
250		$h_5 =$	

Fig. 3.3



(c) On the graph grid provided, plot a graph of the extension (vertical axis) against the force (horizontal axis).

Draw the best straight line through these points.

[3]

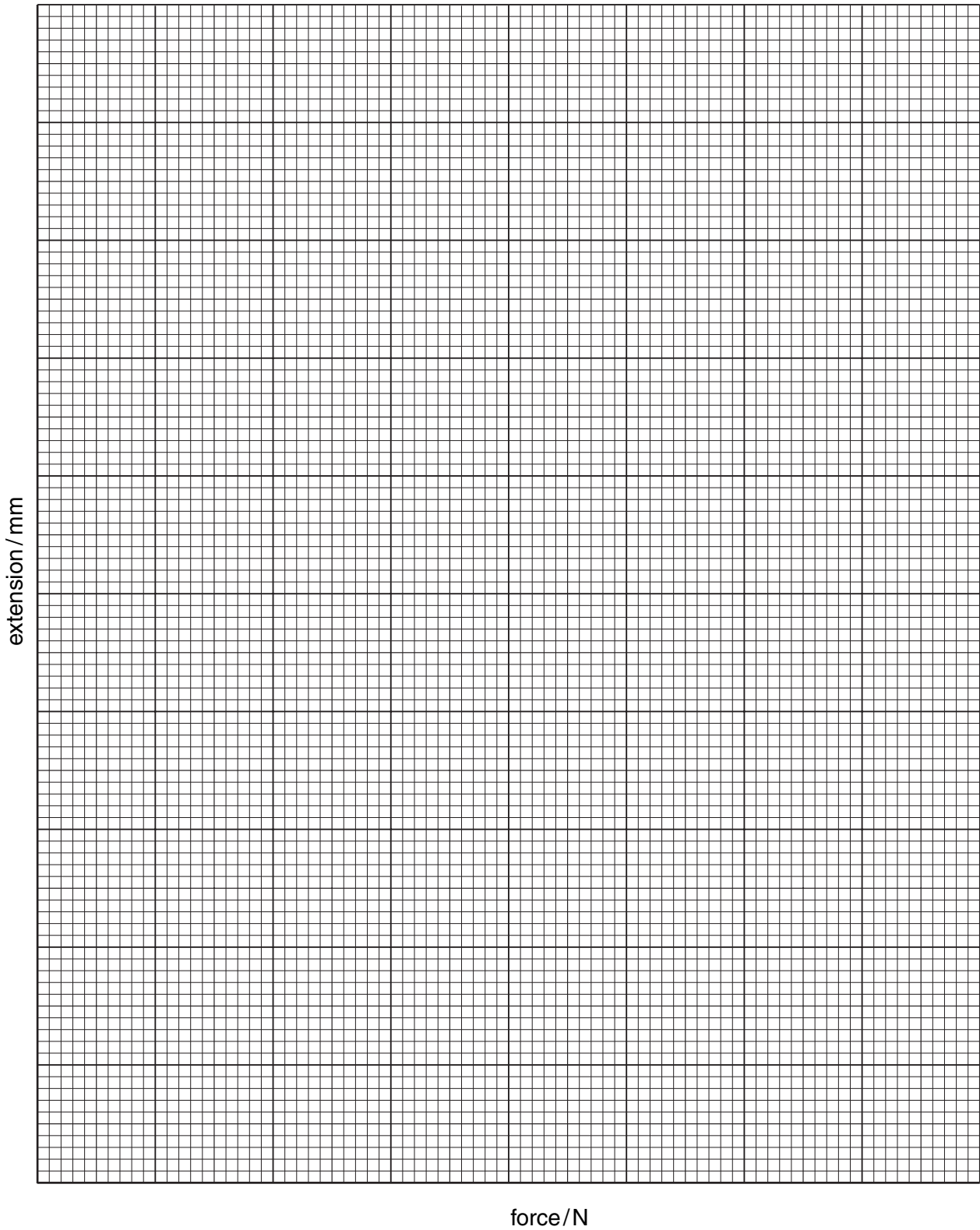

(d) What is the relationship between the applied force and the extension of the spring?

.....[1]

- (e) Describe how you would find the mass of an object using the same apparatus. You need to state the measurements you would make and show how the mass can be calculated.

.....

.....

.....

.....[2]

4 (a) Fig. 4.1 shows an experiment to illustrate diffusion.

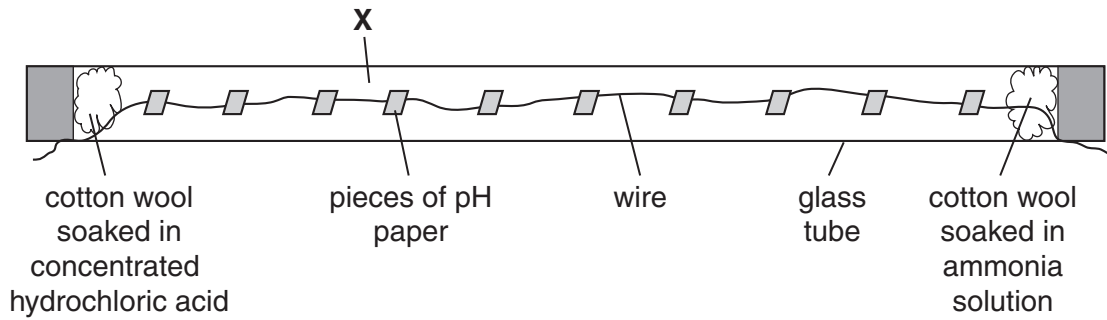

**Fig. 4.1**

Some pieces of pH paper were threaded on to a thin wire which was then placed inside a long glass tube. Two pieces of cotton wool, one soaked in concentrated hydrochloric acid and the other soaked in ammonia solution, were placed at opposite ends of the closed glass tube. Each solution gave off a gas.

(i) What was the colour of the pH paper closest to the ammonia? Explain your answer.

colour .....

explanation .....

.....

[2]

(ii) What was the colour of the pH paper closest to the hydrochloric acid?

.....

[1]

(b) Suggest the colour of the pH paper at the point where the two gases meet in the tube. Explain your answer.

colour .....

explanation .....

.....

[2]

(c) The two gases met at point X as shown in Fig. 4.1.

(i) Which gas moved faster? .....

(ii) Suggest a reason for this. ....

.....

[2]

(d) What does the word *diffusion* mean?

.....[1]

- 5 (a) A student placed a crystal of potassium manganate(VII) in a test-tube of water. He stood the test-tube in a rack and left it there. The diagrams, Fig. 5.1, show what the tube looked like after two hours and after one day.

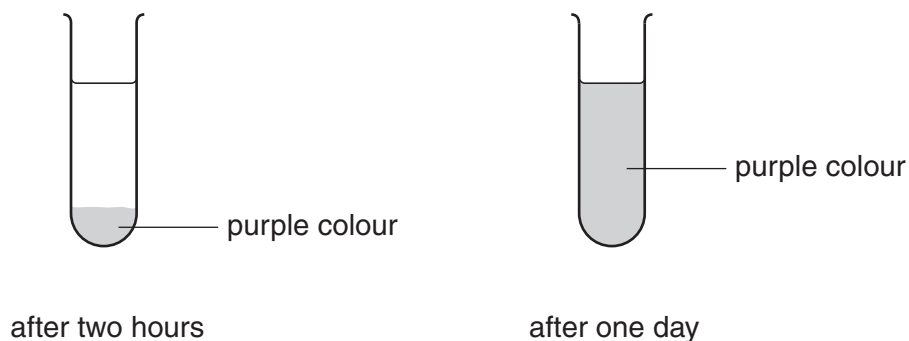

Fig. 5.1

- (i) Explain what happened to the particles in the crystal.

.....  
 .....  
 .....[2]

- (ii) Suggest two ways to speed up the processes happening in the tube.

1. ....  
 2. ....[2]

- (b) Calcium hydroxide is a white solid that is slightly soluble in water. The student placed some calcium hydroxide into a test-tube with five drops of Universal Indicator. The Universal Indicator turned purple.

What does this colour tell you about the calcium hydroxide?

.....[1]

- (c) The student carefully poured some dilute ethanoic acid into the mixture from (b) and left the tube in the rack. Fig. 5.2 shows what the tube looked like after a few hours.

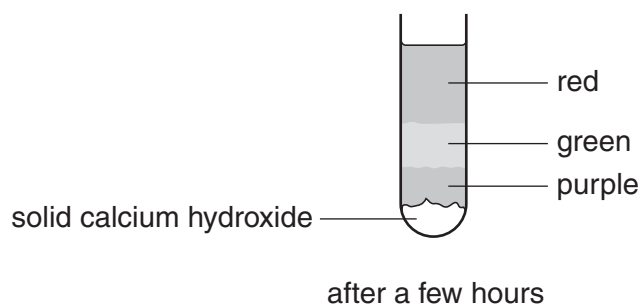
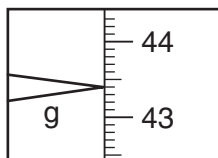

**Fig. 5.2**

- (i) Explain the meaning of the word *dilute*.  
 .....[1]
- (ii) Explain what has happened in the green part of the solution.  
 .....  
 .....[2]
- (iii) Explain what has happened in the purple part of the solution.  
 .....  
 .....[1]
- (iv) Write a word equation for the reaction that has taken place in the tube.  
 .....[1]

- 6 A student does an experiment to find out what happens when sodium chloride is dissolved in water.

She measures  $50 \text{ cm}^3$  of water into a weighed beaker and adds some sodium chloride crystals. Then she stirs the mixture to make the sodium chloride dissolve. The diagrams, Fig. 6.1, show the balance readings for the three weighings.



mass of beaker

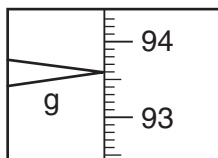

mass of beaker  
+  $50 \text{ cm}^3$  water

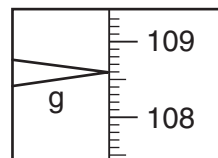

mass of beaker  
+ sodium chloride solution

**Fig. 6.1**

- (a) Record the balance readings.

mass of the beaker = ..... g

mass of the beaker +  $50 \text{ cm}^3$  water = ..... g

mass of the beaker + sodium chloride solution = ..... g

[3]

- (b) (i) Calculate the mass of the sodium chloride solution.

mass of sodium chloride solution = ..... g

[1]

- (ii) Calculate the mass of the sodium chloride crystals.

mass of sodium chloride crystals = ..... g

[1]

- (c) The student pours the solution into a measuring cylinder. The scale of the measuring cylinder is shown in Fig. 6.2.

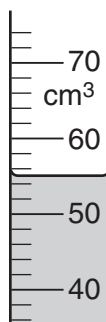

Fig. 6.2

What is the volume of the solution?

..... cm<sup>3</sup> [1]

- (d) Which of the experimental results in (a), (b) and (c) must the student use to calculate the **density** of sodium chloride solution?

.....  
 .....[1]

- (e) The student wants to do an experiment to find the volume of the solid sodium chloride crystals. The teacher tells her that sodium chloride will not dissolve in hexane, an organic liquid.

Explain how she can use hexane and a 50 cm<sup>3</sup> measuring cylinder to find the accurate **volume** of 15 g of sodium chloride crystals.

.....  
 .....  
 .....  
 .....[3]

