

Centre Number	Candidate Number	Name
---------------	------------------	------

CAMBRIDGE INTERNATIONAL EXAMINATIONS
International General Certificate of Secondary Education

PHYSICAL SCIENCE

0652/05

Paper 5 Practical Test

May/June 2003

1 hour 30 minutes

Candidates answer on the Question Paper.

Additional Materials: As listed in Instructions to Supervisors

READ THESE INSTRUCTIONS FIRST

Write your Centre number, candidate number and name on all the work you hand in.
Write in dark blue or black pen in the spaces provided on the Question Paper.
You may use a soft pencil for any diagrams, graphs or rough working.
Do not use staples, paper clips, highlighters, glue or correction fluid.

Answer **all** questions.

At the end of the examination, fasten all your work securely together.

The number of marks is given in brackets [] at the end of each question or part question.

Chemistry practical notes for this paper are printed on page 8.

If you have been given a label, look at the details. If any details are incorrect or missing, please fill in your correct details in the space given at the top of this page.

Stick your personal label here, if provided.

For Examiner's Use	
1	
2	
Total	

This document consists of **7** printed pages and **1** blank page.



- 1 You are going to investigate the relationship between applied force and extension of a spring.
- (a)
- With a small piece of plasticine, fix the pin **P** at right angles to the spring, as shown in Fig. 1.1. Hang the spring from the metal rod of a clamp.
 - Attach the mass carrier to the spring.
 - Fix the metre rule vertically in the clamp close to the spring with its zero mark at the bottom.

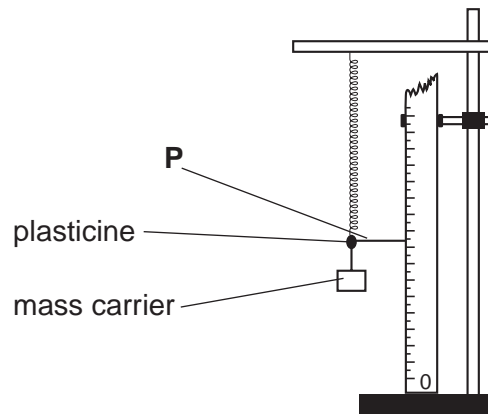

Fig. 1.1

- Make sure that you have left enough space under the spring for it to stretch at least 30 cm when the masses are hung on it.
- (i) Read off the height, h_0 , of the pointer on the metre rule. Record h_0 in millimetres in the table Fig. 1.2.
- Now add 50 g to the carrier and read off the new height, h , of the pointer. Record h in the table Fig. 1.2. Repeat by adding further 50 g masses until you have added a total of 250 g.
- (ii) Complete the table, noting that you are required to convert each mass into a force, (1 kg is 10 N) and calculate the total increase in length of the spring each time.

total mass added / g	force / N	pointer reading h / mm	total increase in length (extension) = $h_0 - h$ / mm
0	0	$h_0 =$	0

Fig. 1.2

[4]

(b) On the graph grid provided, plot a graph of the extension of the spring (vertical axis) against the force. Draw the best straight line through these points.

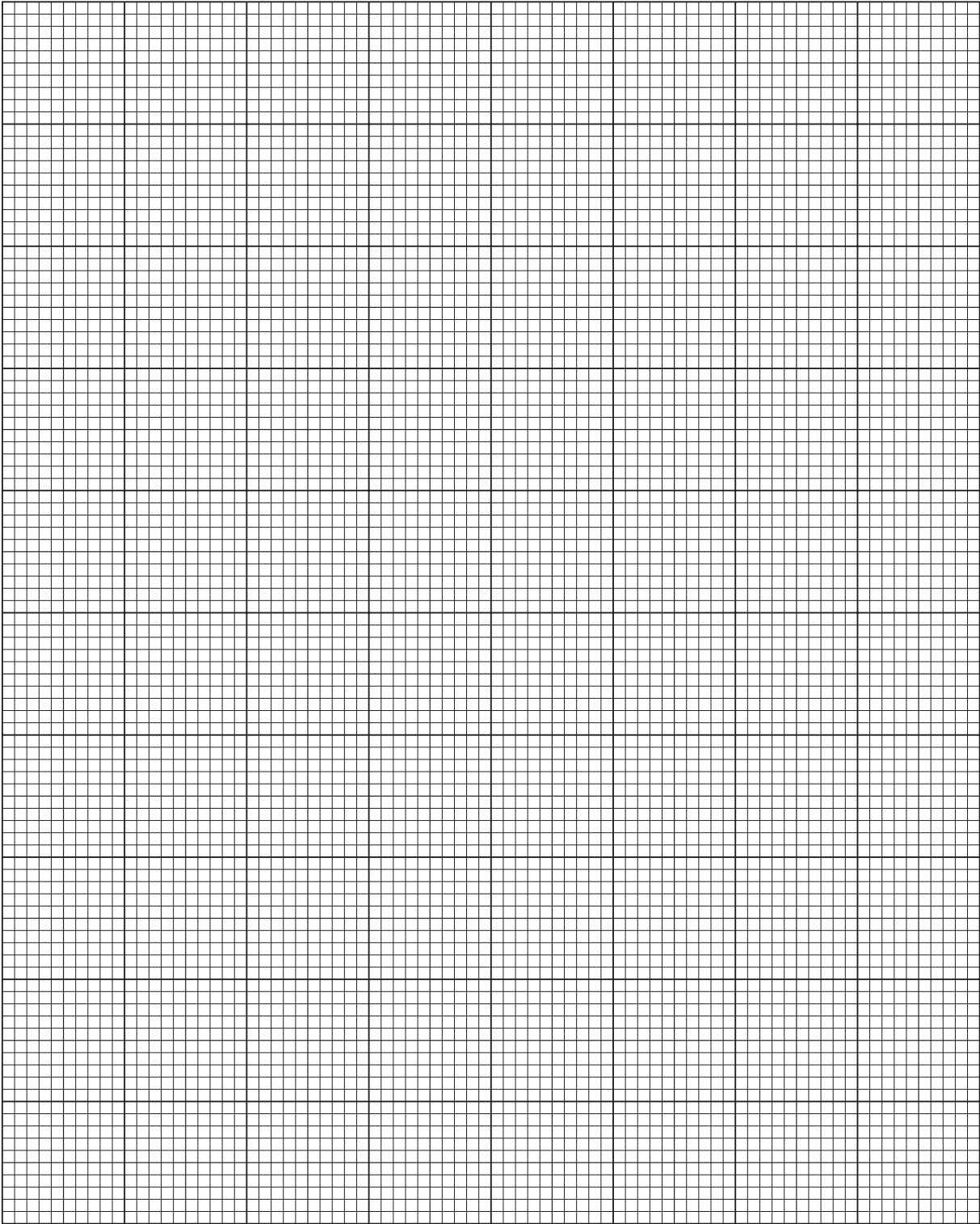

[4]

(c) Read off from your graph the extension produced by a force of 3.5 N.

extension =mm [1]

(d) What is the relationship between the applied force and extension of the spring?

.....
.....[2]

(e) A spring is made from thicker wire and the same experiment carried out. Draw a line on your graph for a spring made from this thicker wire. Label the line 'thicker wire'. [1]

(f) Describe how you would find the mass of an object using the experiment already carried out. You need to state the measurements you would make and how the mass would be calculated.

.....
.....
.....
.....
.....
.....
.....[3]

Please turn over for Question 2

2 You are going to investigate the potential difference produced when two different metals are in contact.

- (a)
- Clean the pieces of metal with sandpaper to ensure good electrical contact.
 - Connect a wire from the negative terminal of the voltmeter to the strip of magnesium, using a crocodile clip.
 - Place the strip of magnesium under a circle of filter paper.
 - Add the very dilute acid to the filter paper using a dropping pipette. Add sufficient to make the whole piece of paper wet.
 - Connect a piece of wire from the positive terminal of the voltmeter to the zinc strip using a crocodile clip.
 - Press the piece of zinc down onto the wet filter paper above the magnesium strip. See Fig. 2.1.
 - Read the potential difference and record its value in the table, Fig. 2.2. You should also note which metal is acting as the negative pole of the cell produced by the two metals.

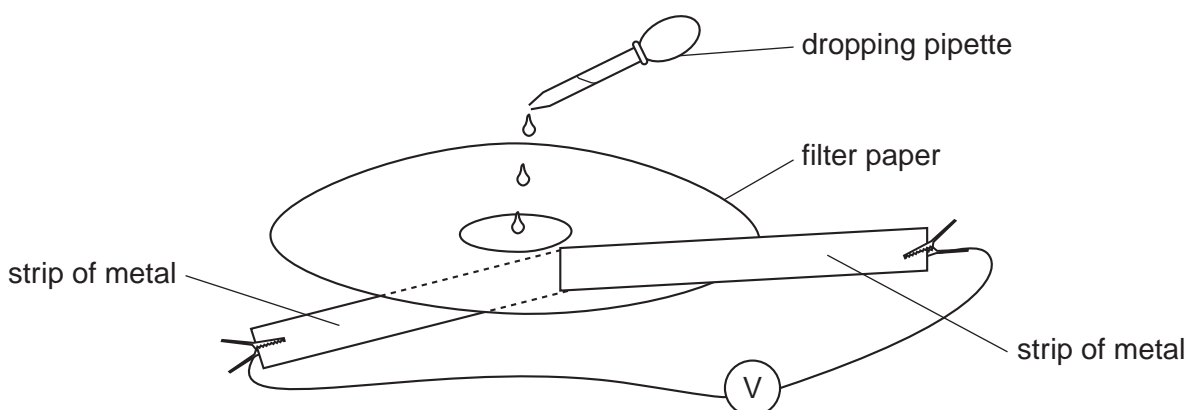

Fig. 2.1

pairs of metals	negative metal	potential difference/V
magnesium and zinc		
copper and magnesium		
copper and zinc		

Fig. 2.2

[4]

- (b) Repeat the procedure with copper and magnesium, then copper and zinc. Use a fresh circle of filter paper each time.

- (c) From your results, state which of the three metals is the most negative. Explain your answer.

.....
.....[2]

- (d) Place the metals in order of decreasing reactivity, the most reactive first.

.....[1]

- (e) (i) Place a piece of magnesium into about 5 cm³ of copper(II) sulphate solution in a test-tube. Record all your observations.

observations

.....
.....[3]

- (ii) Explain these observations.

.....
.....
.....[2]

- (f) Imagine you are given a metal X together with copper, magnesium and zinc. Describe a method to place the four metals in order of decreasing reactivity, using the apparatus and results of your previous experiment.

.....
.....
.....
.....[3]

CHEMISTRY PRACTICAL NOTES

Test for anions

<i>anion</i>	<i>test</i>	<i>test result</i>
carbonate (CO_3^{2-})	add dilute acid	effervescence, carbon dioxide produced
chloride (Cl^-) [in solution]	acidify with dilute nitric acid, then add aqueous silver nitrate	white ppt.
nitrate (NO_3^-) [in solution]	add aqueous sodium hydroxide, then aluminium foil; warm carefully	ammonia produced
sulphate (SO_4^{2-}) [in solution]	acidify, then add aqueous barium chloride <i>or</i> aqueous barium nitrate	white ppt.

Test for aqueous cations

<i>cation</i>	<i>effect of aqueous sodium hydroxide</i>	<i>effect of aqueous ammonia</i>
ammonium (NH_4^+)	ammonia produced on warming	–
copper(II) (Cu^{2+})	light blue ppt., insoluble in excess	light blue ppt., soluble in excess, giving a dark blue solution
iron(II) (Fe^{2+})	green ppt., insoluble in excess	green ppt., insoluble in excess
iron(III) (Fe^{3+})	red-brown ppt., insoluble in excess	red-brown ppt., insoluble in excess
zinc (Zn^{2+})	white ppt., soluble in excess, giving a colourless solution	white ppt., soluble in excess, giving a colourless solution

Test for gases

<i>gas</i>	<i>test and test result</i>
ammonia (NH_3)	turns damp litmus paper blue
carbon dioxide (CO_2)	turns lime water milky
chlorine (Cl_2)	bleaches damp litmus paper
hydrogen (H_2)	'pops' with a lighted splint
oxygen (O_2)	relights a glowing splint