

CAMBRIDGE INTERNATIONAL EXAMINATIONS  
International General Certificate of Secondary Education

**ADDITIONAL MATHEMATICS**

**0606/01**

Paper 1

May/June 2003

**2 hours**

Additional Materials: Answer Booklet/Paper  
Electronic calculator  
Graph paper  
Mathematical tables

**READ THESE INSTRUCTIONS FIRST**

If you have been given an Answer Booklet, follow the instructions on the front cover of the Booklet.  
Write your Centre number, candidate number and name on all the work you hand in.  
Write in dark blue or black pen on both sides of the paper.  
You may use a soft pencil for any diagrams or graphs.  
Do not use staples, paper clips, highlighters, glue or correction fluid.

Answer **all** the questions.

Write your answers on the separate answer booklet/paper provided.

Give non-exact numerical answers correct to 3 significant figures, or 1 decimal place in the case of angles in degrees, unless a different level of accuracy is specified in the question.

At the end of the examination, fasten all your work securely together.

The number of marks is given in brackets [ ] at the end of each question or part question.

The total number of marks for this paper is 80.

The use of an electronic calculator is expected, where appropriate.

You are reminded of the need for clear presentation in your answers.

This document consists of **5** printed pages and **3** blank pages.



**Mathematical Formulae****1. ALGEBRA***Quadratic Equation*

For the equation  $ax^2 + bx + c = 0$ ,

$$x = \frac{-b \pm \sqrt{(b^2 - 4ac)}}{2a}.$$

*Binomial Theorem*

$$(a + b)^n = a^n + \binom{n}{1} a^{n-1}b + \binom{n}{2} a^{n-2}b^2 + \dots + \binom{n}{r} a^{n-r}b^r + \dots + b^n,$$

where  $n$  is a positive integer and  $\binom{n}{r} = \frac{n!}{(n-r)! r!}$ .

**2. TRIGONOMETRY***Identities*

$$\sin^2 A + \cos^2 A = 1.$$

$$\sec^2 A = 1 + \tan^2 A.$$

$$\operatorname{cosec}^2 A = 1 + \cot^2 A.$$

*Formulae for  $\Delta ABC$* 

$$\frac{a}{\sin A} = \frac{b}{\sin B} = \frac{c}{\sin C}.$$

$$a^2 = b^2 + c^2 - 2bc \cos A.$$

$$\Delta = \frac{1}{2} bc \sin A.$$

- 1 Find the values of  $k$  for which the line  $y = kx - 2$  meets the curve  $y^2 = 4x - x^2$ . [4]
- 2 The area of a rectangle is  $(1 + \sqrt{6})\text{m}^2$ . The length of one side is  $(\sqrt{3} + \sqrt{2})\text{m}$ . Find, without using a calculator, the length of the other side in the form  $\sqrt{a} - \sqrt{b}$ , where  $a$  and  $b$  are integers. [4]
- 3 (i) Find the first 3 terms in the expansion, in ascending powers of  $x$ , of  $(2 - x)^5$ . [3]  
(ii) Hence find the value of the constant  $k$  for which the coefficient of  $x$  in the expansion of  $(k + x)(2 - x)^5$  is  $-8$ . [2]
- 4 An ocean liner is travelling at  $36 \text{ km h}^{-1}$  on a bearing of  $090^\circ$ . At 0600 hours the liner, which is 90 km from a lifeboat and on a bearing of  $315^\circ$  from the lifeboat, sends a message for assistance. The lifeboat sets off immediately and travels in a straight line at constant speed, intercepting the liner at 0730 hours. Find the speed at which the lifeboat travels. [5]
- 5 Find the distance between the points of intersection of the curve  $y = 3 + \frac{4}{x}$  and the line  $y = 4x + 9$ . [6]
- 6 Given that  $\mathbf{A} = \begin{pmatrix} 2 & -3 \\ 0 & 1 \end{pmatrix}$ , find  $\mathbf{B}$  such that  $4\mathbf{A}^{-1} + \mathbf{B} = \mathbf{A}^2$ . [6]
- 7 The function  $f$  is defined, for  $0^\circ \leq x \leq 360^\circ$ , by  $f(x) = 4 - \cos 2x$ .  
(i) State the amplitude and period of  $f$ . [2]  
(ii) Sketch the graph of  $f$ , stating the coordinates of the maximum points. [4]
- 8 The universal set  $\mathcal{E}$  and the sets  $O$ ,  $P$  and  $S$  are given by  
 $\mathcal{E} = \{x : x \text{ is an integer such that } 3 \leq x \leq 100\}$ ,  
 $O = \{x : x \text{ is an odd number}\}$ ,  
 $P = \{x : x \text{ is a prime number}\}$ ,  
 $S = \{x : x \text{ is a perfect square}\}$ .

In the Venn diagram below, each of the sets  $O$ ,  $P$  and  $S$  is represented by a circle.

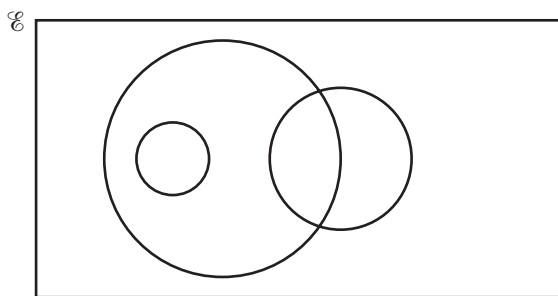

- (i) Copy the Venn diagram and label each circle with the appropriate letter. [2]  
(ii) Place each of the numbers 34, 35, 36 and 37 in the appropriate part of your diagram. [2]  
(iii) State the value of  $n(O \cap S)$  and of  $n(O \cup S)$ . [3]

9 Solve

(i)  $\log_4 2 + \log_9 (2x + 5) = \log_8 64$ , [4]

(ii)  $9^y + 5(3^y - 10) = 0$ . [4]

10

$x$	2	3	4	5	6
$y$	9.2	8.8	9.4	10.4	11.6

The table above shows experimental values of the variables  $x$  and  $y$ . On graph paper draw the graph of  $xy$  against  $x^2$ . [3]

Hence

(i) express  $y$  in terms of  $x$ , [4]

(ii) find the value of  $x$  for which  $x = \frac{45}{y}$ . [2]

11 A curve has the equation  $y = xe^{2x}$ .

(i) Find the  $x$ -coordinate of the turning point of the curve. [4]

(ii) Find the value of  $k$  for which  $\frac{d^2y}{dx^2} = ke^{2x}(1+x)$ . [3]

(iii) Determine whether the turning point is a maximum or a minimum. [2]

12 Answer only **one** of the following two alternatives.

**EITHER**

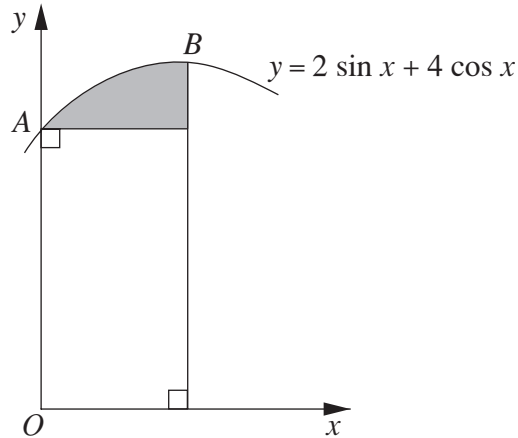

The diagram shows part of the curve  $y = 2 \sin x + 4 \cos x$ , intersecting the  $y$ -axis at  $A$  and with its maximum point at  $B$ . A line is drawn from  $A$  parallel to the  $x$ -axis and a line is drawn from  $B$  parallel to the  $y$ -axis. Find the area of the shaded region. [11]

**OR**

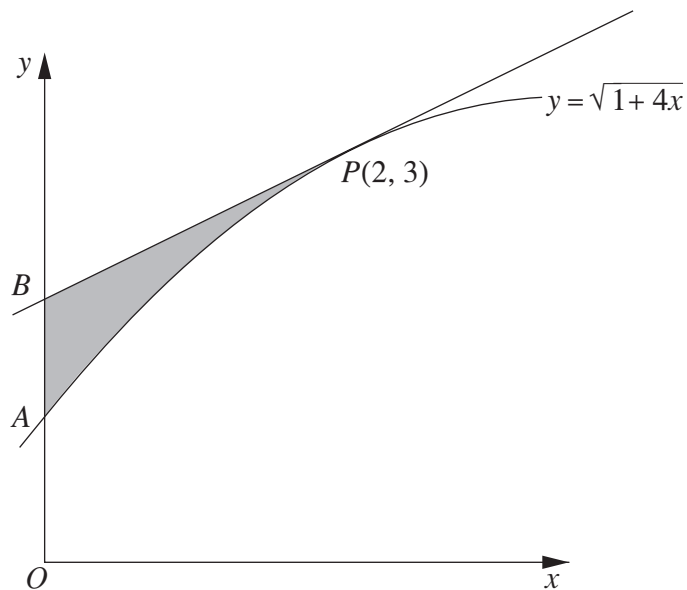

The diagram shows part of the curve  $y = \sqrt{1 + 4x}$ , intersecting the  $y$ -axis at  $A$ . The tangent to the curve at the point  $P(2, 3)$  intersects the  $y$ -axis at  $B$ . Find the area of the shaded region  $ABP$ . [11]

**BLANK PAGE**

**BLANK PAGE**

**BLANK PAGE**