



UNIVERSITY OF CAMBRIDGE INTERNATIONAL EXAMINATIONS
International General Certificate of Secondary Education

CANDIDATE
NAME

CENTRE
NUMBER

--	--	--	--	--

CANDIDATE
NUMBER

--	--	--	--



MATHEMATICS

0581/33

Paper 3 (Core)

October/November 2011

2 hours

Candidates answer on the Question Paper.

Additional Materials: Electronic calculator Geometrical instruments
 Mathematical tables (optional) Tracing paper (optional)

READ THESE INSTRUCTIONS FIRST

Write your Centre number, candidate number and name on all the work you hand in.
Write in dark blue or black pen.
You may use a pencil for any diagrams or graphs.
Do not use staples, paper clips, highlighters, glue or correction fluid.
DO NOT WRITE IN ANY BARCODES.

Answer **all** questions.
If working is needed for any question it must be shown below that question.
Electronic calculators should be used.
If the degree of accuracy is not specified in the question, and if the answer is not exact, give the answer to three significant figures. Give answers in degrees to one decimal place.
For π , use either your calculator value or 3.142.

At the end of the examination, fasten all your work securely together.
The number of marks is given in brackets [] at the end of each question or part question.
The total of the marks for this paper is 104.

This document consists of **16** printed pages.



1 Caroline goes to a shop.

The shopping bill shows the items she buys.

Item	Cost (\$)
1 packet of cereal	1.20
3 bottles of water at \$0.45 each	1.35
2 cartons of milk at \$0.82 each	
4 kg of rice at \$0.90 per kg	
0.7 kg of apples at \$2.40 per kg	

(a) Complete the shopping bill. [3]

(b) (i) Calculate the total amount of money Caroline spends at the shop.

Answer(b)(i) \$ [1]

(ii) Caroline pays with a \$10 note.

Calculate how much change she receives.

Answer(b)(ii) \$ [1]

For
Examiner's
Use

- (c) Caroline arrived at the shop at 09 48.
She was in the shop for 18 minutes.
She then took 5 minutes to walk to a café.
She was in the café for 20 minutes.

(i) At what time did Caroline leave the café?

Answer(c)(i) [2]

- (ii) Caroline then went to the library.
She was in the library for 45 minutes.

Work out the ratio

time in the shop : time in the library.

Give your answer in its simplest form.

Answer(c)(ii) : [2]

- (d) When Caroline left home she had \$36.50.
She returned home with \$12.74.

Calculate \$12.74 as a percentage of \$36.50.

Answer(d) % [1]

*For
Examiner's
Use*

- 2 James takes 12 science tests during one school term.
These are his marks.

18 11 20 15 15 12 15 9 11 15 14 13

(a) Find

(i) the range,

Answer(a)(i) [1]

(ii) the mode,

Answer(a)(ii) [1]

(iii) the median,

Answer(a)(iii) [2]

(iv) the mean.

Answer(a)(iv) [2]

*For
Examiner's
Use*

- (b) James sorts his marks into three levels.
The levels are Satisfactory (less than 12), Good (12 to 16) and Excellent (more than 16).

*For
Examiner's
Use*

- (i) Complete the frequency table to show this information.

Level	Satisfactory	Good	Excellent
Frequency		7	

[1]

- (ii) Complete the pie chart accurately and label each sector.

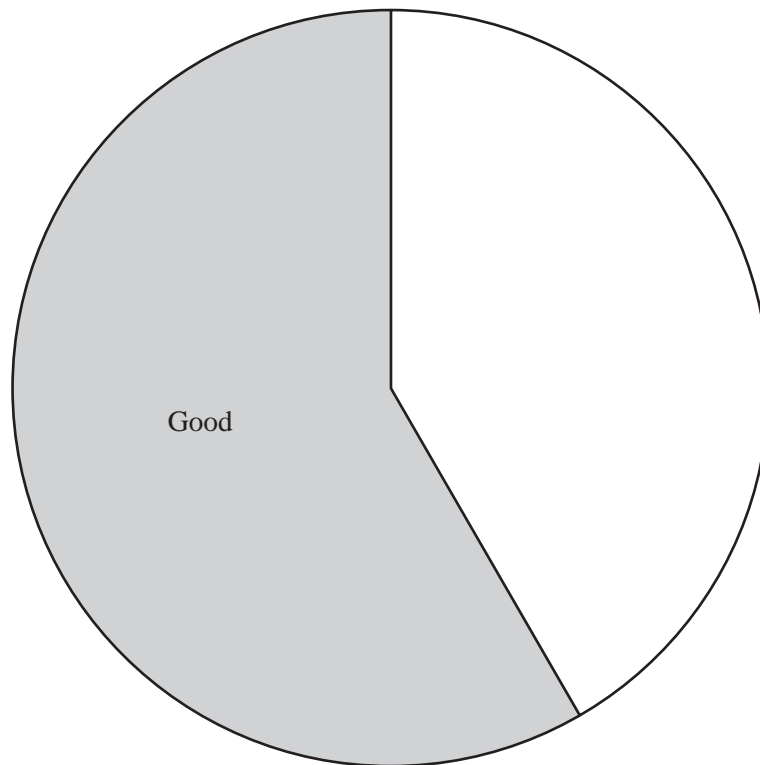

[2]

- (c) What fraction of the marks were Satisfactory or Good?
Give your answer in its lowest terms.

Answer(c) [2]

3

For
Examiner's
Use

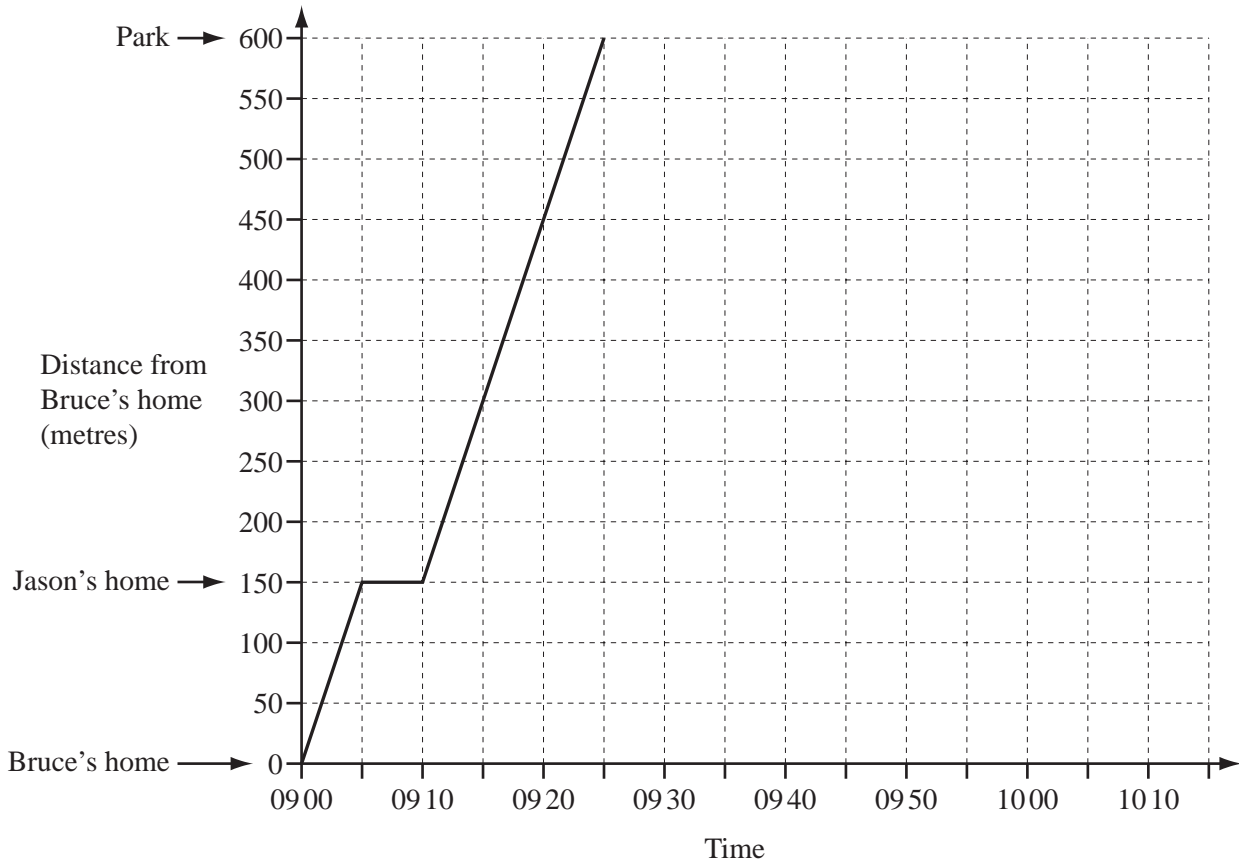

One morning, Bruce walked from his home to Jason's home and the two boys walked to the park. The distance-time graph shows Bruce's journey.

(a) How many minutes was Bruce at Jason's home?

Answer(a) min [1]

(b) How far from the park were Bruce and Jason at 0920?

Answer(b) m [2]

(c) Work out the speed at which Bruce and Jason walked to the park. Give your answer in km/h.

Answer(c) km/h [3]

(d) Bruce stayed at the park for 35 minutes. He then walked home at a speed of 60 metres per minute.

Complete the graph to show Bruce's time at the park and his journey home. [3]

4 (a)

For
Examiner's
Use

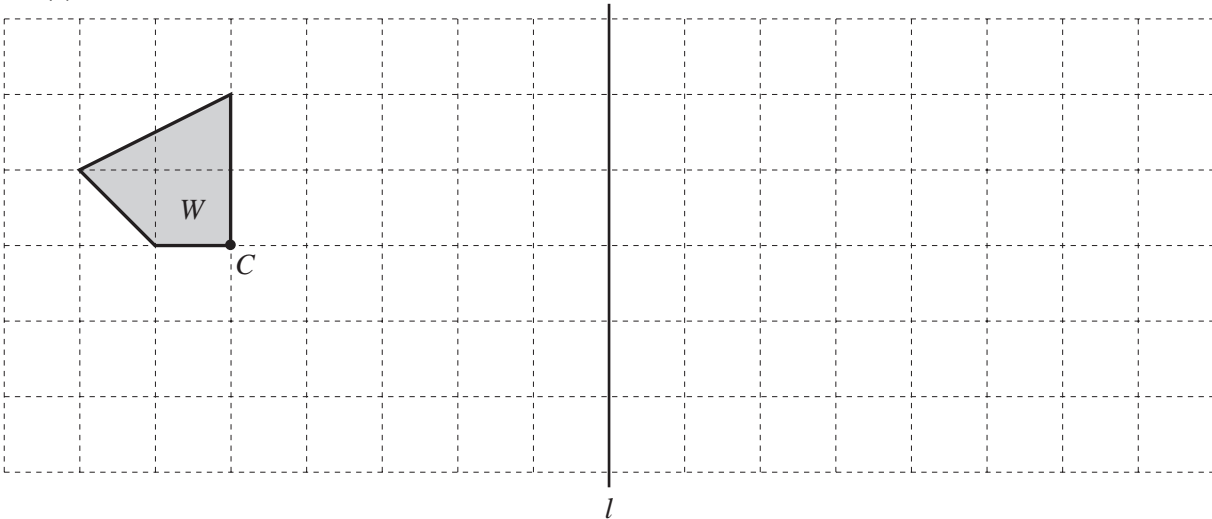

On the grid,

- (i) draw the reflection of W in the line l , [2]
- (ii) rotate W anticlockwise through 90° , about the point C . [2]

(b)

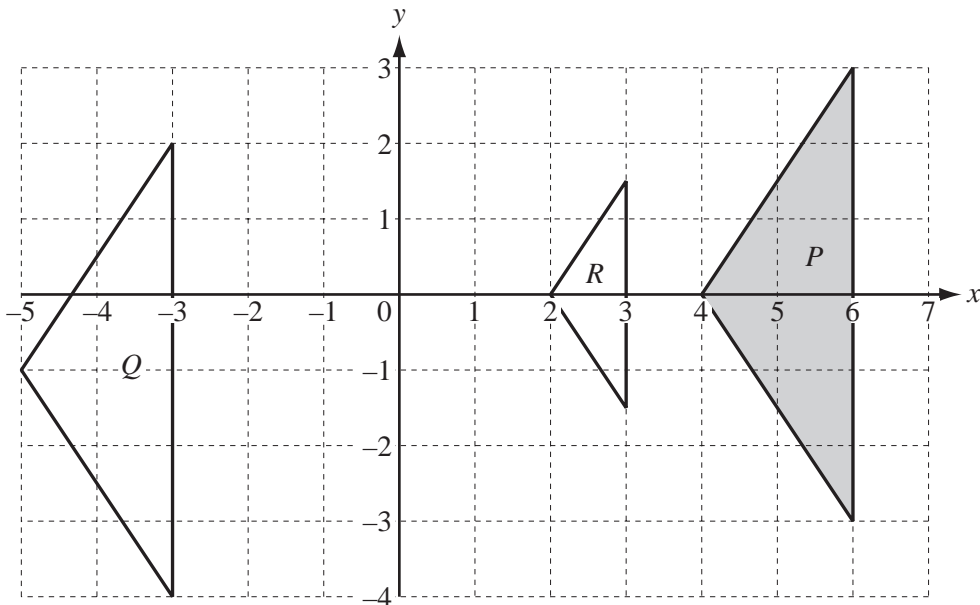

- (i) Describe fully the **single** transformation that maps P onto Q .

Answer(b)(i) [2]

- (ii) Describe fully the **single** transformation that maps P onto R .

Answer(b)(ii) [3]

5 (a)

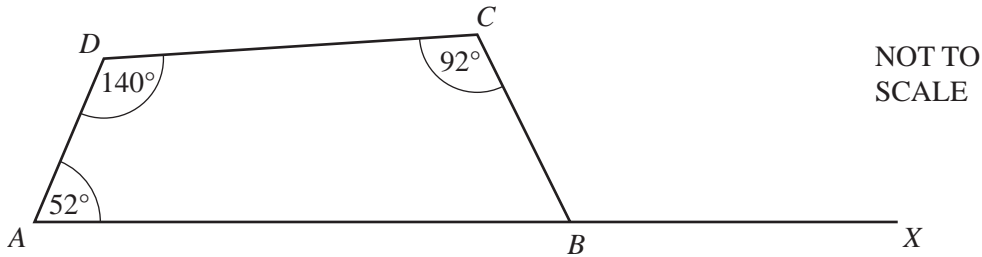

For
Examiner's
Use

In the quadrilateral $ABCD$, angle $BAD = 52^\circ$, angle $ADC = 140^\circ$ and angle $DCB = 92^\circ$.
 AB is extended to X .

(i) Calculate angle CBX .

Answer(a)(i) Angle $CBX =$ [2]

(ii) The line BY bisects angle CBX .
 Complete the statement.

The lines BY and AD are
 because [2]

(b)

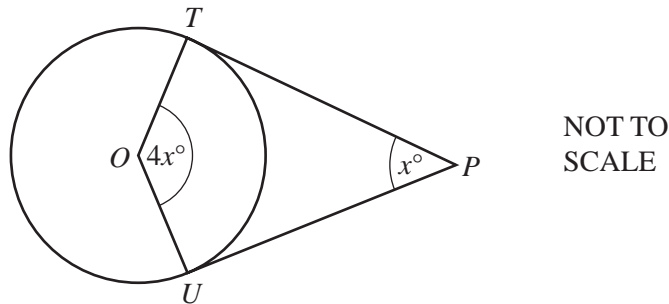

The diagram shows a circle, centre O .
 PT and PU are tangents to the circle at T and U .
 Angle $TPU = x^\circ$ and angle $TOU = 4x^\circ$.

Calculate the value of x .

Answer(b) $x =$ [3]

(c) The exterior angle of a regular polygon is 20° .

Calculate the number of sides of the polygon.

Answer(c) [2]

6 (a) Complete the table for $y = 4 + 2x - x^2$.

x	-2	-1	0	1	2	3	4
y		1		5		1	

[2]

(b) On the grid, draw the graph of $y = 4 + 2x - x^2$ for $-2 \leq x \leq 4$.

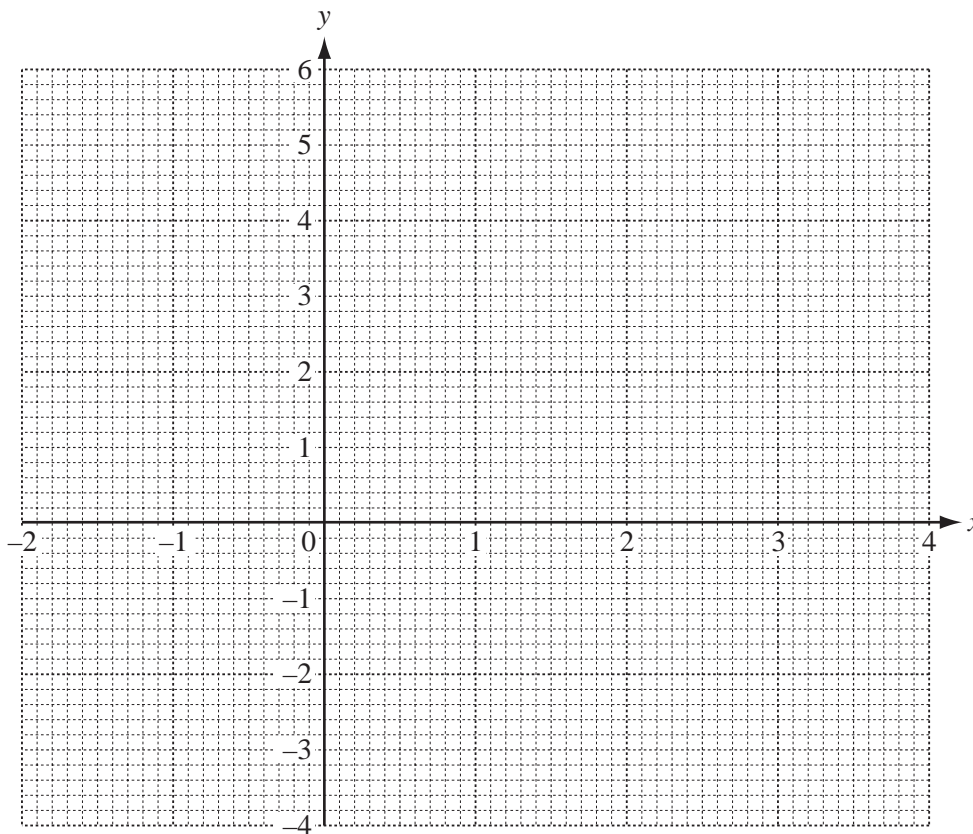

[4]

(c) (i) Draw the line of symmetry of the graph.

[1]

(ii) Write down the equation of this line of symmetry.

Answer(c)(ii)

[1]

(d) Use your graph to solve the equation $4 + 2x - x^2 = 0$.

Answer(d) $x =$ or $x =$ [2]

For
Examiner's
Use

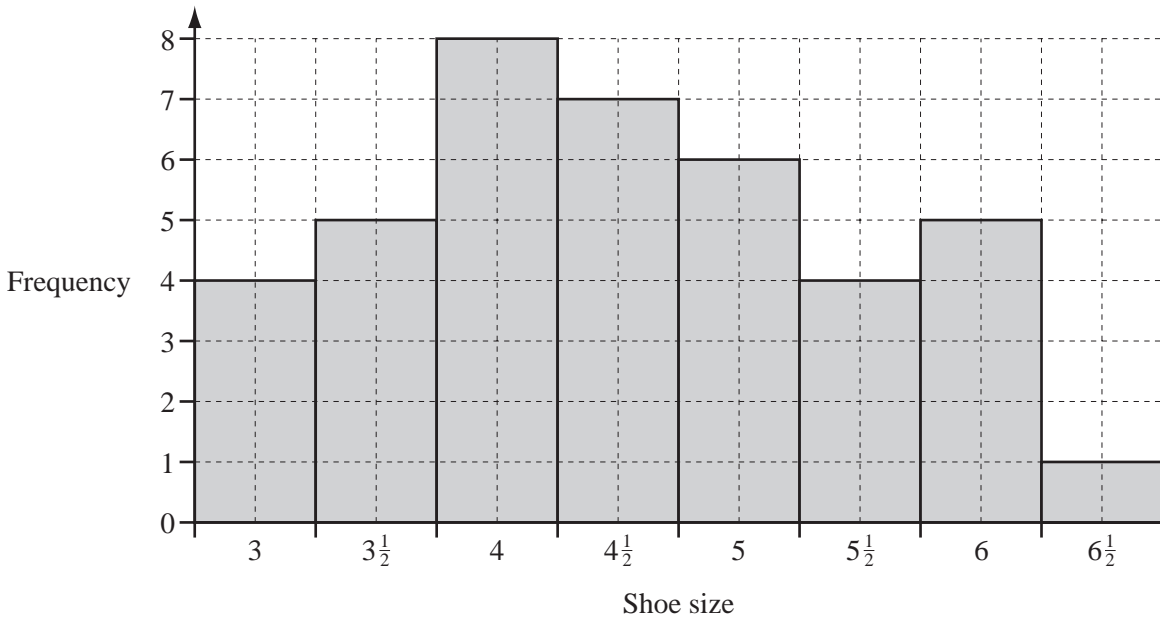

The bar chart shows the frequencies of the shoe sizes for a group of students.

(a) Use the information in the bar chart to complete the frequency table.

Shoe size	3	$3\frac{1}{2}$	4	$4\frac{1}{2}$	5	$5\frac{1}{2}$	6	$6\frac{1}{2}$
Frequency	4							1

[2]

(b) How many students are in the group?

Answer(b) [1]

(c) Calculate the mean shoe size.

Answer(c) [3]



(a) Construct triangle ABC accurately, with $AC = 10$ cm and $BC = 8$ cm. [2]
The line AB has been drawn for you.

(b) (i) Using a straight edge and compasses only, construct the bisector of angle A . [2]

(ii) The bisector of angle A meets BC at X .

Measure the length of BX .

Answer(b)(ii) $BX =$ cm [1]

(c) (i) Using a straight edge and compasses only, construct the perpendicular bisector of AB . [2]

(ii) The perpendicular bisector of AB meets AC at Y and AX at Z .

Measure angle CYZ .

Answer(c)(ii) Angle $CYZ =$ [1]

(d) Shade the region inside triangle ABC which is

and

- nearer to AB than to AC
- nearer to B than to A .

[1]

9

For
Examiner's
Use

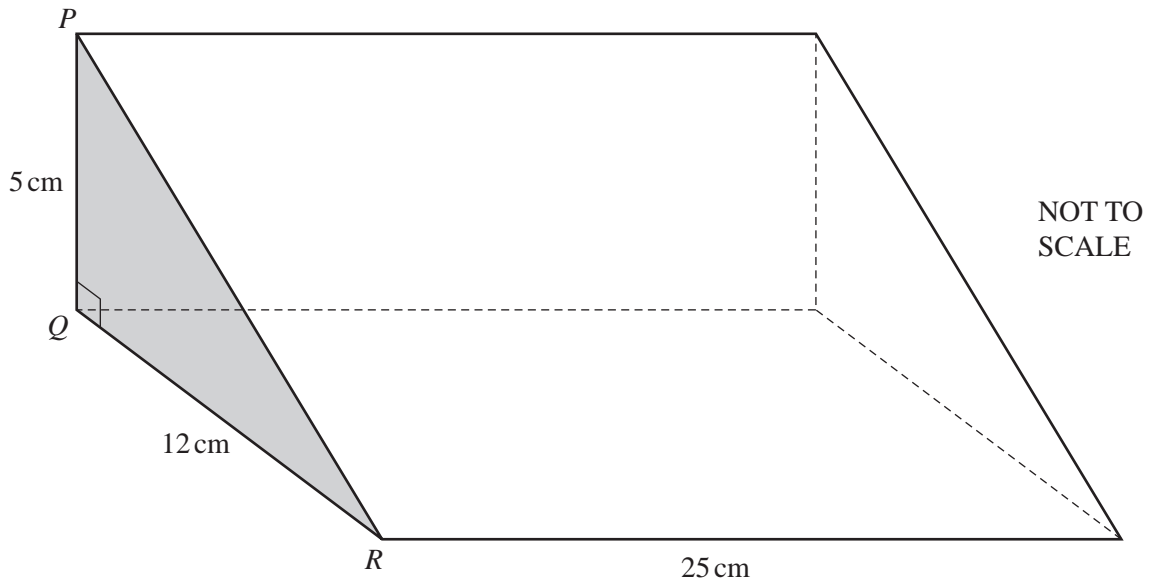

The diagram shows a solid triangular prism of length 25 cm.
The cross-section of the prism is triangle PQR .
 $PQ = 5$ cm, $QR = 12$ cm and angle $PQR = 90^\circ$.

(a) (i) Calculate the volume of the prism.

Answer(a)(i) cm^3 [3]

(ii) The prism is made from wood.
The mass of 1 cm^3 of the wood is 0.96 g.

Calculate the mass of the prism.
Give your answer in kilograms.

Answer(a)(ii) kg [2]

- (b) (i) Show that $PR = 13$ cm.

Answer(b)(i)

[2]

- (ii) The prism is completely covered with plastic at a cost of \$0.08 per square centimetre.

By finding the total area of the two triangles and the three rectangles, calculate the total cost of the plastic used.

Answer(b)(ii) \$ [4]

*For
Examiner's
Use*

10 (a) Tatiana goes for a walk.

- (i) She walks for 15 minutes at a speed of 80 metres per minute.

Calculate the distance she walks.

Answer(a)(i) m [1]

- (ii) She then walks for a further p minutes at w metres per minute.

Write down an expression, in terms of p and w , for the **total** distance Tatiana walks.

Answer(a)(ii) m [1]

- (iii) Write down an expression, in terms of p and w , for Tatiana's average speed, in metres per minute.

Answer(a)(iii) m/min [2]

(b) The volume, V , of a solid is given by the following formula.

$$V = 3b\left(t + \frac{1}{2}m\right)$$

(i) Find V when $b = 4$, $t = 5$ and $m = 6$.

Answer(b)(i) $V =$ [2]

(ii) Find b when $t = 3$, $m = 2$ and $V = 84$.

Answer(b)(ii) $b =$ [3]

For
Examiner's
Use

Question 11 is printed on the next page.

11 (a) Write down the next term in each of the following sequences.

(i) 8, 15, 22, 29, [1]

(ii) 3, 6, 12, 24, [1]

(iii) 1, 4, 9, 16, [1]

(iv) 0, 3, 8, 15, [1]

(b) Write down an expression, in terms of n , for the n th term of

(i) the sequence in **part(a)(iii)**,

Answer(b)(i) [1]

(ii) the sequence in **part(a)(iv)**.

Answer(b)(ii) [1]

(c) The n th term of a sequence is $7n - 3$.

(i) Write down the value of the 4th term.

Answer(c)(i) [1]

(ii) Which term has a value of 592?

Answer(c)(ii) [2]

(d) 1, 2, 2, 4, 8, 32, 256,

Work out the next two terms of this sequence.

Answer(d) , [2]

Permission to reproduce items where third-party owned material protected by copyright is included has been sought and cleared where possible. Every reasonable effort has been made by the publisher (UCLES) to trace copyright holders, but if any items requiring clearance have unwittingly been included, the publisher will be pleased to make amends at the earliest possible opportunity.

University of Cambridge International Examinations is part of the Cambridge Assessment Group. Cambridge Assessment is the brand name of University of Cambridge Local Examinations Syndicate (UCLES), which is itself a department of the University of Cambridge.