



UNIVERSITY OF CAMBRIDGE INTERNATIONAL EXAMINATIONS
International General Certificate of Secondary Education

CANDIDATE
NAME

CENTRE
NUMBER

--	--	--	--	--

CANDIDATE
NUMBER

--	--	--	--	--

* 6 8 1 4 0 0 1 8 2 6 *

MATHEMATICS

0581/43

Paper 4 (Extended)

October/November 2010

2 hours 30 minutes

Candidates answer on the Question Paper.

Additional Materials:

Electronic calculator
Mathematical tables (optional)

Geometrical instruments
Tracing paper (optional)

READ THESE INSTRUCTIONS FIRST

Write your Centre number, candidate number and name on all the work you hand in.

Write in dark blue or black pen.

You may use a pencil for any diagrams or graphs.

Do not use staples, paper clips, highlighters, glue or correction fluid.

DO NOT WRITE IN ANY BARCODES.

Answer **all** questions.

If working is needed for any question it must be shown below that question.

Electronic calculators should be used.

If the degree of accuracy is not specified in the question, and if the answer is not exact, give the answer to three significant figures. Give answers in degrees to one decimal place.

For π use either your calculator value or 3.142.

At the end of the examination, fasten all your work securely together.

The number of marks is given in brackets [] at the end of each question or part question.

The total of the marks for this paper is 130.

This document consists of **19** printed pages and **1** blank page.



- 1 Thomas, Ursula and Vanessa share \$200 in the ratio

$$\text{Thomas} : \text{Ursula} : \text{Vanessa} = 3 : 2 : 5.$$

- (a) Show that Thomas receives \$60 and Ursula receives \$40.

Answer(a)

[2]

- (b) Thomas buys a book for \$21.
What percentage of his \$60 does Thomas have left?

Answer(b) % [2]

- (c) Ursula buys a computer game for \$36.80 in a sale.
The sale price is 20% less than the original price.
Calculate the original price of the computer game.

Answer(c) \$ [3]

- (d) Vanessa buys some books and some pencils.
Each book costs \$12 **more** than each pencil.
The total cost of 5 books and 2 pencils is \$64.20.
Find the cost of one pencil.

Answer(d) \$ [3]

2

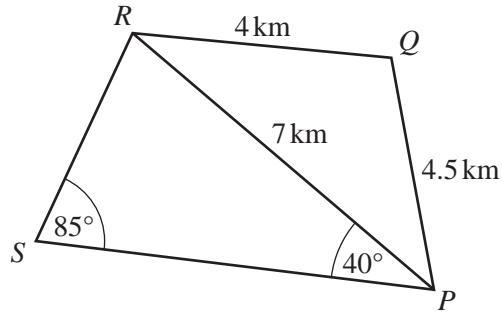
NOT TO
SCALEFor
Examiner's
Use

The diagram shows five straight roads.
 $PQ = 4.5$ km, $QR = 4$ km and $PR = 7$ km.
 Angle $RPS = 40^\circ$ and angle $PSR = 85^\circ$.

- (a) Calculate angle PQR and show that it rounds to 110.7° .

Answer(a)

[4]

- (b) Calculate the length of the road RS and show that it rounds to 4.52 km.

Answer(b)

[3]

- (c) Calculate the area of the quadrilateral $PQRS$.
 [Use the value of 110.7° for angle PQR and the value of 4.52 km for RS .]

Answer(c) km² [5]

- 3 (a) Expand the brackets and simplify.

$$x(x+3)+4x(x-1)$$

For
Examiner's
Use

Answer(a) [2]

- (b) Simplify $(3x^3)^3$.

Answer(b) [2]

- (c) Factorise the following completely.

(i) $7x^7 + 14x^{14}$

Answer(c)(i) [2]

(ii) $xy + xw + 2ay + 2aw$

Answer(c)(ii) [2]

(iii) $4x^2 - 49$

Answer(c)(iii) [1]

(d) Solve the equation.

$$2x^2 + 5x + 1 = 0$$

Show all your working and give your answers correct to 2 decimal places.

*For
Examiner's
Use*

Answer(d) $x =$ or $x =$ [4]

4 (a)

$$\mathbf{A} = \begin{pmatrix} 2 & 3 \\ 4 & 5 \end{pmatrix} \quad \mathbf{B} = \begin{pmatrix} 2 \\ 7 \end{pmatrix} \quad \mathbf{C} = \begin{pmatrix} 1 & 2 \end{pmatrix}$$

Find the following matrices.

(i) \mathbf{AB}

Answer(a)(i) [2]

(ii) \mathbf{CB}

Answer(a)(ii) [2]

(iii) \mathbf{A}^{-1} , the inverse of \mathbf{A}

Answer(a)(iii) [2]

(b) Describe fully the **single** transformation represented by the matrix $\begin{pmatrix} 1 & 0 \\ 0 & -1 \end{pmatrix}$.

Answer(b) [2]

(c) Find the 2 by 2 matrix that represents an anticlockwise rotation of 90° about the origin.

Answer(c)

$$\begin{pmatrix} & \\ & \end{pmatrix}$$

[2]

*For
Examiner's
Use*

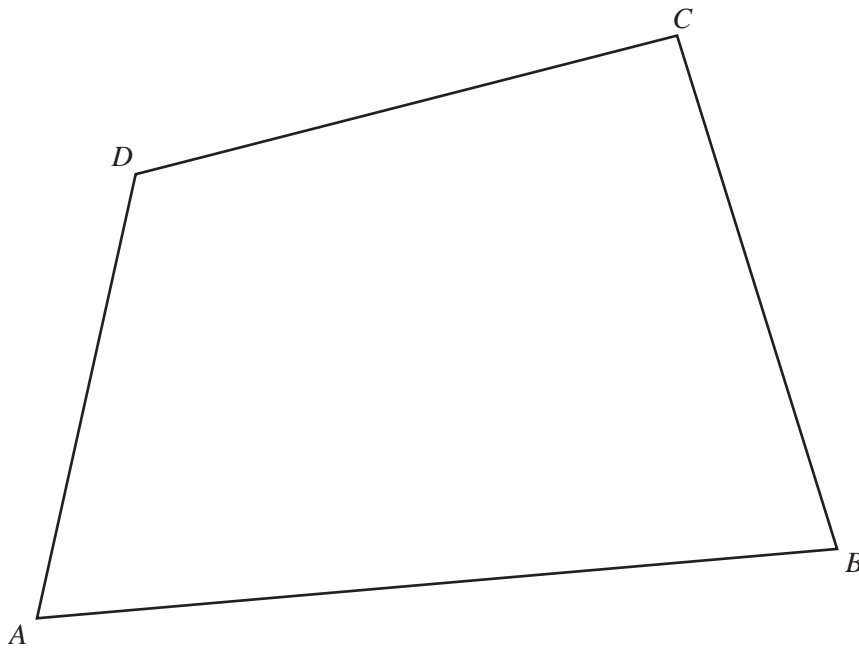

The diagram shows an area of land $ABCD$ used for a shop, a car park and gardens.

(a) Using a straight edge and compasses only, construct

(i) the locus of points equidistant from C and from D , [2]

(ii) the locus of points equidistant from AD and from AB . [2]

(b) The shop is on the land nearer to D than to C and nearer to AD than to AB .

Write the word SHOP in this region on the diagram. [1]

(c) (i) The scale of the diagram is 1 centimetre to 20 metres.
The gardens are the part of the land less than 100 m from B .
Draw the boundary for the gardens. [1]

(ii) The car park is the part of the land not used for the shop and not used for the gardens.
Shade the car park region on the diagram. [1]

6 Sacha either walks or cycles to school.

On any day, the probability that he walks to school is $\frac{3}{5}$.

(a) (i) A school term has 55 days.

Work out the expected number of days Sacha walks to school.

Answer(a)(i) [1]

(ii) Calculate the probability that Sacha walks to school on the first 5 days of the term.

Answer(a)(ii) [2]

(b) When Sacha walks to school, the probability that he is late is $\frac{1}{4}$.

When he cycles to school, the probability that he is late is $\frac{1}{8}$.

(i) Complete the tree diagram by writing the probabilities in the four spaces provided.

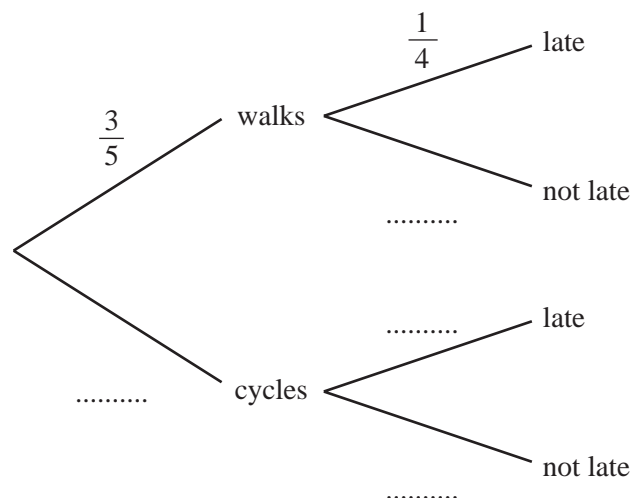

[3]

(ii) Calculate the probability that Sacha cycles to school and is late.

For
Examiner's
Use

Answer(b)(ii) [2]

(iii) Calculate the probability that Sacha is late to school.

Answer(b)(iii) [2]

- 7 (a) Complete the table for the function $f(x) = \frac{x^3}{10} + 1$.

For
Examiner's
Use

x	-4	-3	-2	-1	0	1	2	3
$f(x)$		-1.7	0.2	0.9	1	1.1	1.8	

[2]

- (b) On the grid, draw the graph of $y = f(x)$ for $-4 \leq x \leq 3$.

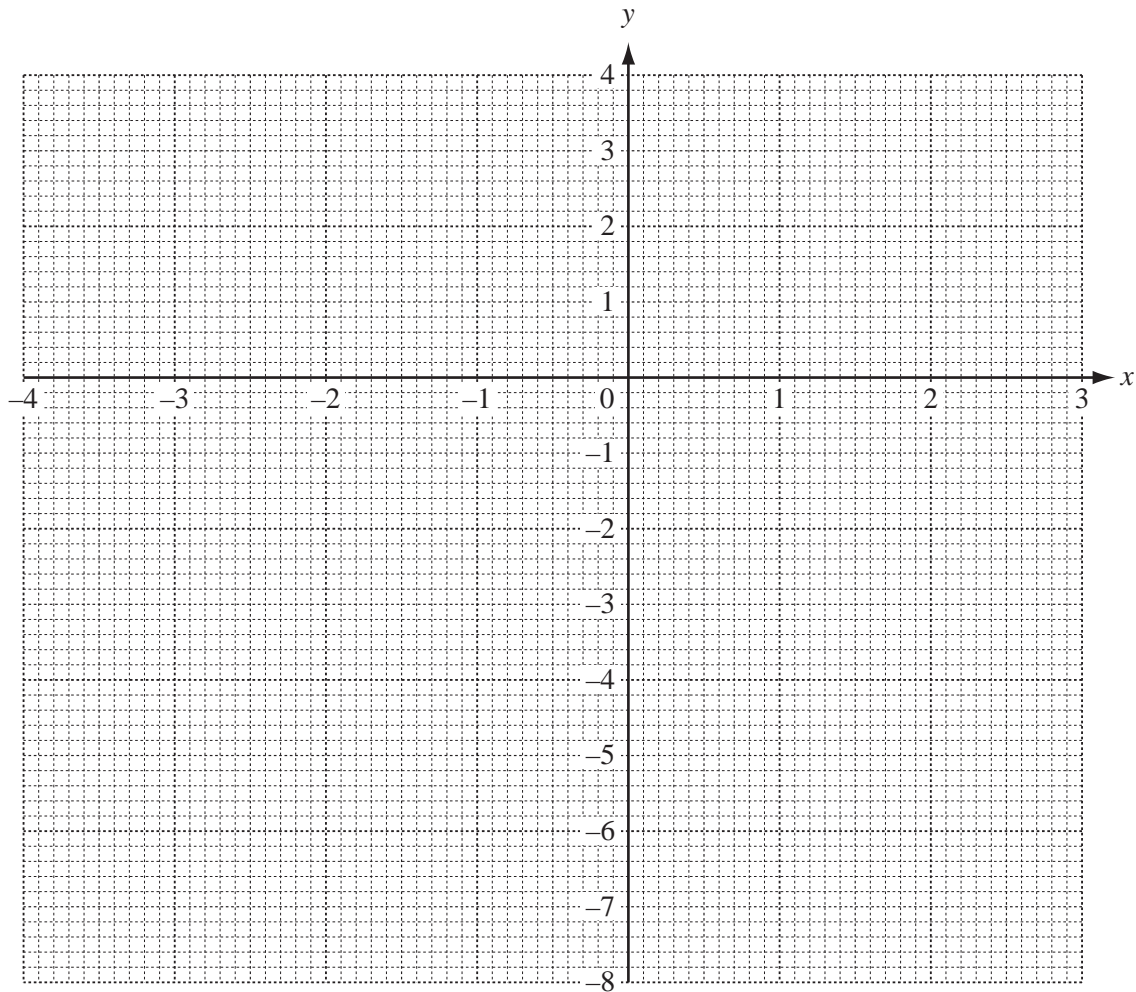

[4]

- (c) Complete the table for the function $g(x) = \frac{4}{x}$, $x \neq 0$.

x	-4	-3	-2	-1	1	2	3
$g(x)$	-1	-1.3				2	1.3

[2]

(d) On the grid, draw the graph of $y = g(x)$ for $-4 \leq x \leq -1$ and $1 \leq x \leq 3$.

[3]

For
Examiner's
Use

(e) (i) Use your graphs to solve the equation $\frac{x^3}{10} + 1 = \frac{4}{x}$.

Answer(e)(i) $x =$ or $x =$ [2]

(ii) The equation $\frac{x^3}{10} + 1 = \frac{4}{x}$ can be written as $x^4 + ax + b = 0$.

Find the values of a and b .

Answer(e)(ii) $a =$

$b =$ [2]

8

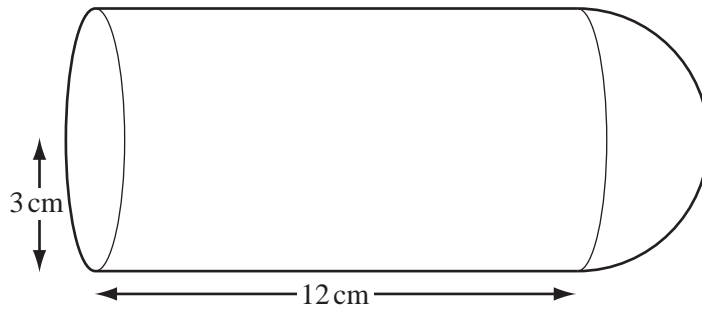
NOT TO
SCALEFor
Examiner's
Use

The diagram shows a solid made up of a hemisphere and a cylinder.
The radius of both the cylinder and the hemisphere is 3 cm.
The length of the cylinder is 12 cm.

(a) (i) Calculate the volume of the solid.

[The volume, V , of a **sphere** with radius r is $V = \frac{4}{3}\pi r^3$.]

Answer(a)(i) cm^3 [4]

(ii) The solid is made of steel and 1 cm^3 of steel has a mass of 7.9 g.
Calculate the mass of the solid.
Give your answer in kilograms.

Answer(a)(ii) kg [2]

- (iii) The solid fits into a box in the shape of a cuboid, 15 cm by 6 cm by 6 cm.
Calculate the volume of the box **not** occupied by the solid.

For
Examiner's
Use

Answer(a)(iii) cm³ [2]

- (b) (i) Calculate the **total** surface area of the solid.
You must show your working.
[The surface area, A , of a **sphere** with radius r is $A = 4\pi r^2$.]

Answer(b)(i) cm² [5]

- (ii) The surface of the solid is painted.
The cost of the paint is \$0.09 per millilitre.
One millilitre of paint covers an area of 8 cm².
Calculate the cost of painting the solid.

Answer(b)(ii) \$ [2]

9 (a)

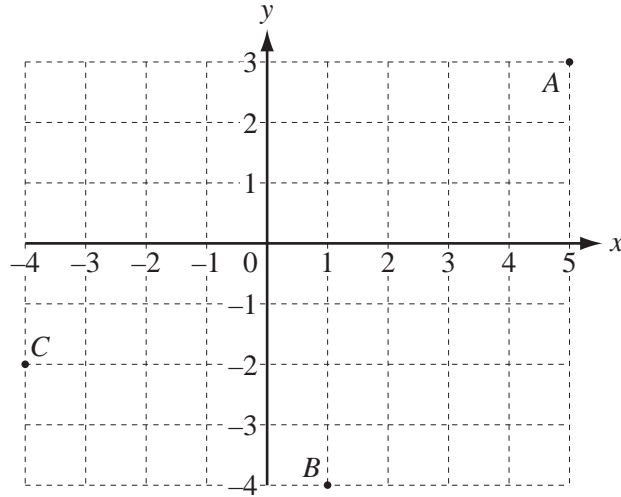

For
Examiner's
Use

The points $A(5, 3)$, $B(1, -4)$ and $C(-4, -2)$ are shown in the diagram.

(i) Write \vec{CA} as a column vector.

Answer(a)(i) $\vec{CA} = \begin{pmatrix} \\ \end{pmatrix}$ [1]

(ii) Find $\vec{CA} - \vec{CB}$ as a single column vector.

Answer(a)(ii) $\begin{pmatrix} \\ \end{pmatrix}$ [2]

(iii) Complete the following statement.

$\vec{CA} - \vec{CB} = \dots\dots\dots$ [1]

(iv) Calculate $|\vec{CA}|$.

Answer(a)(iv) $\dots\dots\dots$ [2]

(b)

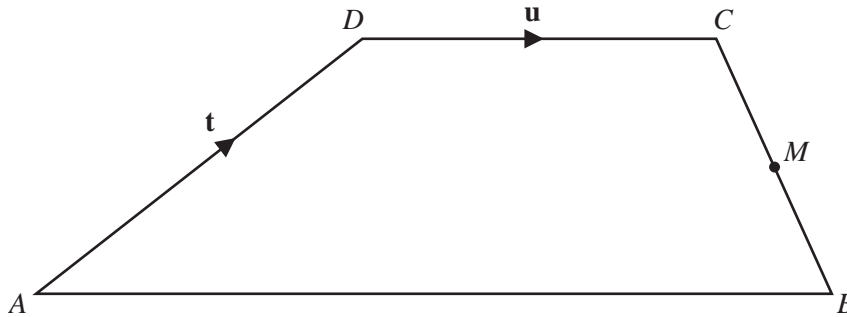

NOT TO SCALE

For
Examiner's
Use

$ABCD$ is a trapezium with DC parallel to AB and $DC = \frac{1}{2}AB$.

M is the midpoint of BC .

$\vec{AD} = \mathbf{t}$ and $\vec{DC} = \mathbf{u}$.

Find the following vectors in terms of \mathbf{t} and / or \mathbf{u} .

Give each answer in its simplest form.

(i) \vec{AB}

Answer(b)(i) $\vec{AB} = \dots\dots\dots$ [1]

(ii) \vec{BM}

Answer(b)(ii) $\vec{BM} = \dots\dots\dots$ [2]

(iii) \vec{AM}

Answer(b)(iii) $\vec{AM} = \dots\dots\dots$ [2]

10 (a) For a set of six integers, the mode is 8, the median is 9 and the mean is 10.

The smallest integer is greater than 6 and the largest integer is 16.

Find the two possible sets of six integers.

For
Examiner's
Use

Answer(a) First set , , , , ,
 Second set , , , , , [5]

(b) One day Ahmed sells 160 oranges.
 He records the mass of each orange.
 The results are shown in the table.

Mass (m grams)	$50 < m \leq 80$	$80 < m \leq 90$	$90 < m \leq 100$	$100 < m \leq 120$	$120 < m \leq 150$
Frequency	30	35	40	40	15

(i) Calculate an estimate of the mean mass of the 160 oranges.

Answer(b)(i) g [4]

(ii) On the grid, complete the histogram to show the information in the table.

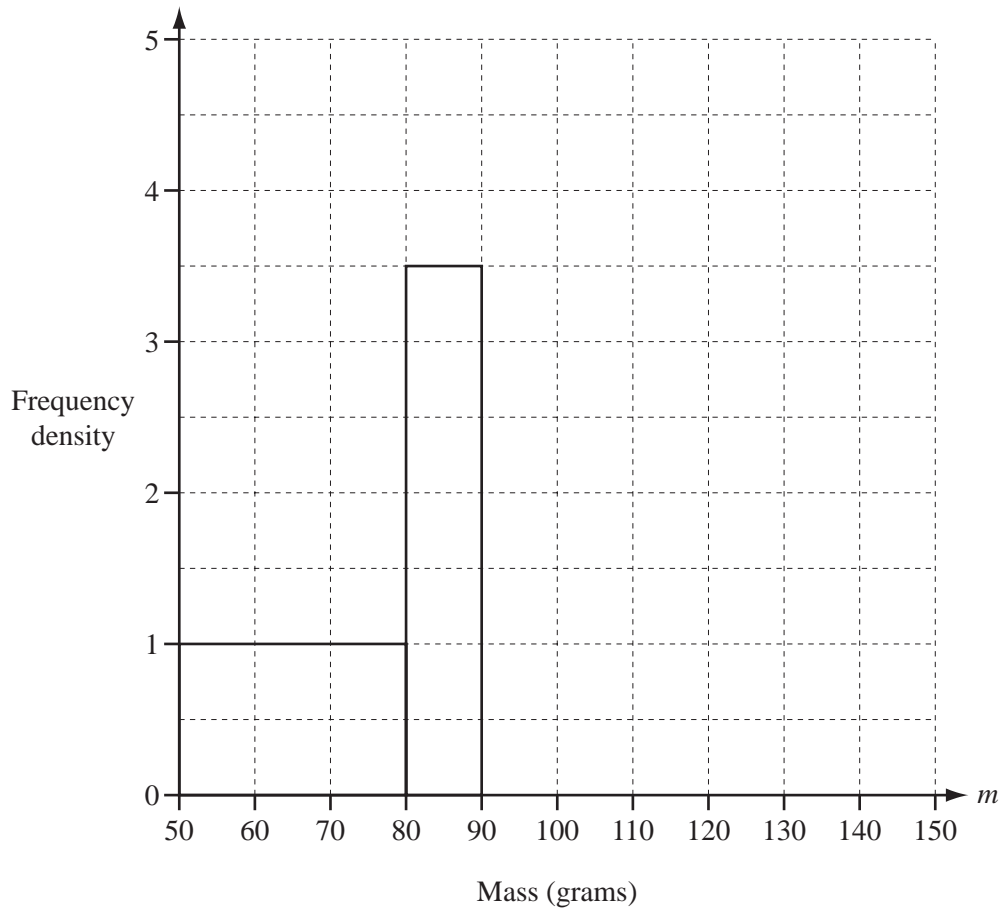

[4]

Question 11 is printed on the next page.

For
Examiner's
Use



Diagram 1

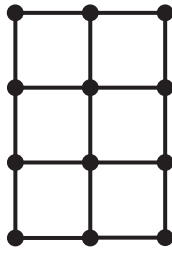

Diagram 2

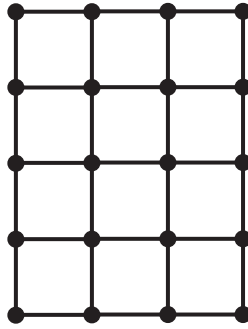

Diagram 3

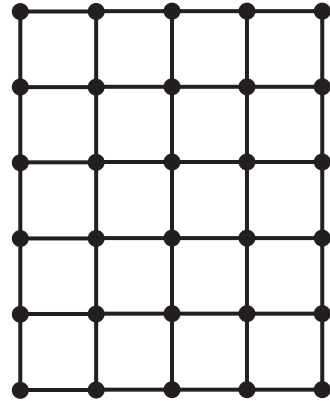

Diagram 4

The first four Diagrams in a sequence are shown above.
Each Diagram is made from dots and one centimetre lines.
The area of each small square is 1 cm^2 .

(a) Complete the table for Diagrams 5 and 6.

Diagram	1	2	3	4	5	6
Area (cm^2)	2	6	12	20		
Number of dots	6	12	20	30		
Number of one centimetre lines	7	17	31	49		

[4]

(b) The **area** of Diagram n is $n(n+1) \text{ cm}^2$.

(i) Find the **area** of Diagram 50.

Answer(b)(i) cm^2 [1]

(ii) Which Diagram has an **area** of 930 cm^2 ?

Answer(b)(ii) [1]

(c) Find, in terms of n , the number of **dots** in Diagram n .

Answer(c) [1]

(d) The number of one centimetre lines in Diagram n is $2n^2 + pn + 1$.

(i) Show that $p = 4$.

Answer(d)(i)

[2]

(ii) Find the number of one centimetre lines in Diagram 10.

Answer(d)(ii) [1]

(iii) Which Diagram has 337 one centimetre lines?

Answer(d)(iii) [3]

(e) For **each** Diagram, the number of squares of area 1 cm^2 is A , the number of dots is D and the number of one centimetre lines is L .

Find a connection between A , D and L that is true for each Diagram.

Answer(e) [1]

BLANK PAGE

Permission to reproduce items where third-party owned material protected by copyright is included has been sought and cleared where possible. Every reasonable effort has been made by the publisher (UCLES) to trace copyright holders, but if any items requiring clearance have unwittingly been included, the publisher will be pleased to make amends at the earliest possible opportunity.

University of Cambridge International Examinations is part of the Cambridge Assessment Group. Cambridge Assessment is the brand name of University of Cambridge Local Examinations Syndicate (UCLES), which is itself a department of the University of Cambridge.