

UNIVERSITY OF CAMBRIDGE INTERNATIONAL EXAMINATIONS
International General Certificate of Secondary Education

MATHEMATICS



Paper 3 (Core)

0580/03 0581/03

Candidates answer on the Question Paper.

Additional Materials: Electronic calculator

Geometrical instruments

October/November 2005

Mathematical tables (optional)

Tracing paper (optional)

2 hours

Candidate
Name

--

Centre
Number

--	--	--	--	--

Candidate
Number

--	--	--	--

READ THESE INSTRUCTIONS FIRST

Write your Centre number, candidate number and name on all the work you hand in.

Write in dark blue or black pen in the spaces provided on the Question Paper.

You may use a pencil for any diagrams or graphs.

Do not use staples, paper clips, highlighters, glue or correction fluid.

DO **NOT** WRITE IN THE BARCODE.

DO **NOT** WRITE IN THE GREY AREAS BETWEEN THE PAGES.

Answer **all** questions.

If working is needed for any question it must be shown below that question.

The number of marks is given in brackets [] at the end of each question or part question.

The total number of marks for this paper is 104.

Electronic calculators should be used.

If the degree of accuracy is not specified in the question, and if the answer is not exact, give the answer to three significant figures. Given answers in degrees to one decimal place.

For π , use either your calculator value or 3.142.

For Examiner's Use

--

This document consists of **12** printed pages.



- 1 (a) Draw accurately the reflection of the letter E in the mirror line m .

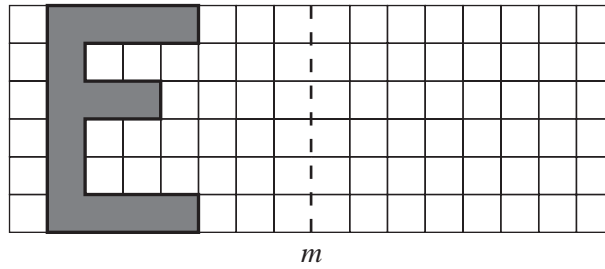

[2]

- (b) Each diagram below shows a shaded letter and its image. In each case describe fully the single transformation which maps the **shaded** figure onto its image. Mark and label any points you need in your descriptions.

(i)

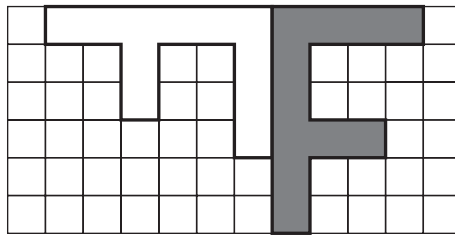

Answer(b)(i)

[3]

(ii)

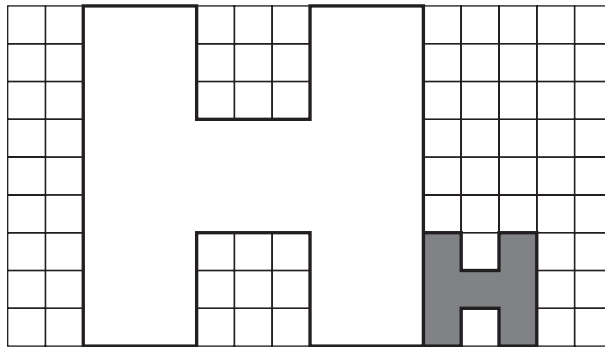

Answer(b)(ii)

[3]

(iii)

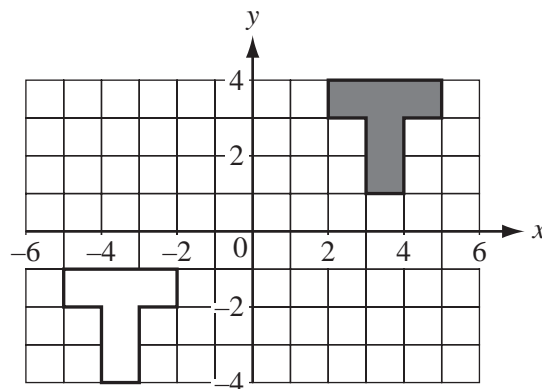

Answer(b)(iii)

[3]

- 2 In the diagram below ABD is a straight line.
 $AB = 4$ m and $AC = 6$ m. Angle $BAC = 90^\circ$.

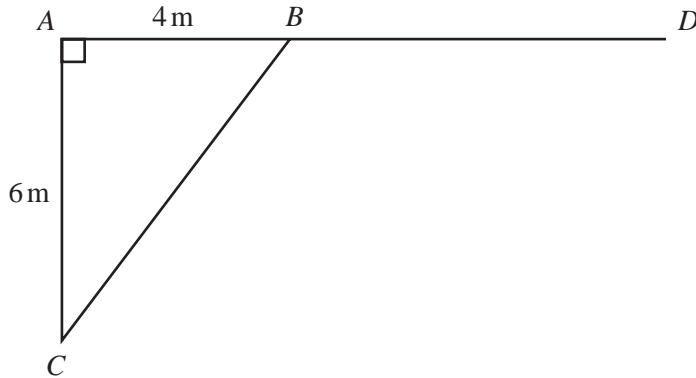

NOT TO
SCALE

- (a) (i) Use trigonometry to calculate angle ABC .

Answer(a)(i) Angle $ABC = \dots\dots\dots$ [2]

- (ii) Find angle CBD .

Answer(a)(ii) Angle $CBD = \dots\dots\dots$ [1]

- (b) Calculate the length of BC .

Answer(b) $BC = \dots\dots\dots$ m [2]

- (c) Work out the perimeter and area of triangle ABC .
Give the correct units for each.

Answer (c) Perimeter = $\dots\dots\dots$ Area = $\dots\dots\dots$ [3]

3 (a) (i) Complete the table of values for $y = x^2 - 2x - 3$.

x	-3	-2	-1	0	1	2	3	4	5
y	12		0		-4	-3	0	5	

[3]

(ii) Draw the graph of $y = x^2 - 2x - 3$ on the grid below.

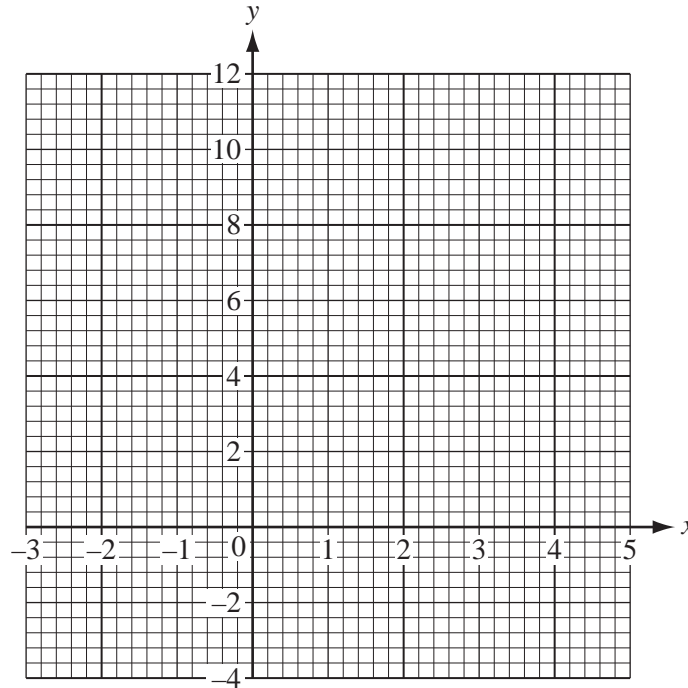

[4]

(iii) Use your graph to find the solutions to $x^2 - 2x - 3 = -1$.
Give your answers to 1 decimal place.

Answer(a)(iii) $x = \dots\dots\dots$ or $x = \dots\dots\dots$ [2]

(b) (i) Complete the table of values for the equation $y = \frac{2}{x}$.

x	0.25	0.5	1	2	3	4	5
y		4		1	0.7	0.5	0.4

[1]

(ii) On the same grid draw the graph of $y = \frac{2}{x}$ for $0.25 \leq x \leq 5$.

[3]

(iii) Write down the x co-ordinate of the point of intersection of your two graphs.

Answer(b)(iii) $x = \dots\dots\dots$ [1]

- 4 Jane records the number of telephone calls she receives each day for two weeks.

5 6 10 0 15 6 12 2 13 16 0 16 6 10

For
Examiner's
Use

- (a) Calculate the mean.

Answer(a) [3]

- (b) Find the median.

Answer(b) [2]

- (c) Write down the mode.

Answer(c) [1]

- (d) Complete the frequency table below.

Number of calls	0 – 4	5 – 9	10 – 14	15 – 19
Frequency				

[2]

- (e) Find the probability that Jane receives

- (i) ten or more calls,

Answer(e)(i) [1]

- (ii) less than five calls.

Answer(e)(ii)..... [1]

- (f) Estimate the number of days in the next six weeks that Jane can expect to receive 10 – 14 calls.

Answer(f) days [2]

5

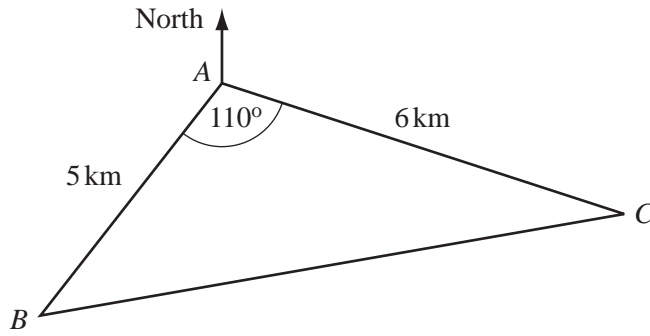
NOT TO
SCALE

In triangle ABC , $AB = 5$ km, $AC = 6$ km and angle $BAC = 110^\circ$.

The bearing of C from A is 100° .

- (a) Make a scale drawing of the triangle ABC .
Use a scale of 1 centimetre to represent 1 kilometre.
Start at the point A marked below, where a North line has been drawn.

For
Examiner's
Use

[4]

(b) **Measure** and write down

(i) angle ABC ,

Answer(b)(i) Angle $ABC = \dots\dots\dots$ [1]

(ii) the bearing of B from C .

Answer(b)(ii)..... [1]

(c) Find the distance in kilometres between B and C .

Answer(c) km [1]

(d) A well is 4 kilometres from A and 5 kilometres from C .

(i) Use your compasses to find **two** possible positions for the well.
Label the two positions P and Q .

[3]

(ii) The well is less than 6 kilometres from B .
Use a measurement from your drawing to complete the following statement.

Answer(d)(ii) The well is at position and is kilometres from B . [2]

- 6 The diagram shows a swimming pool with cross-section $ABCDE$.
The pool is 6 metres long and 3 metres wide.
 $AB = 2$ m, $ED = 1$ m and $BC = 3.6$ m.

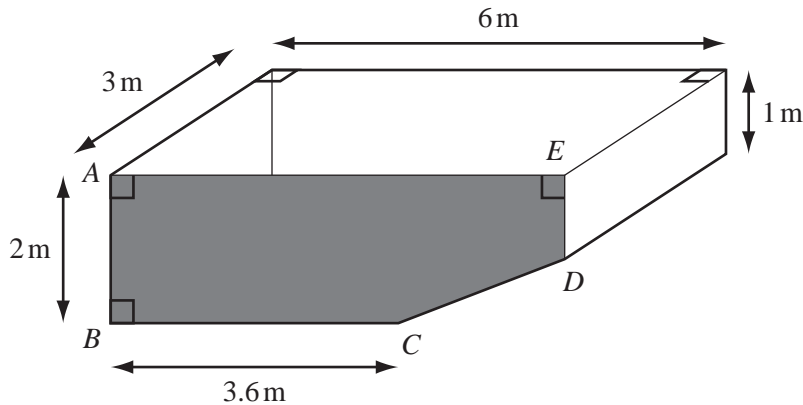

NOT TO
SCALE

- (a) (i) Calculate the area of the cross-section $ABCDE$.
Show your working.

Answer(a)(i) m^2 [4]

- (ii) Calculate the volume of the water in the pool when it is full.
Give your answer in **litres**.
[1 cubic metre is 1000 litres.]

Answer(a)(ii)..... litres [2]

- (iii) One litre of water evaporates every hour for each square metre of the water surface.
How many litres of water will evaporate in 2 hours?

Answer(a)(iii) litres [2]

(b) **Another pool** holds 61 500 litres of water.

Jon uses a hosepipe to fill this pool.

Water flows through the hosepipe at 1000 litres per hour.

- (i) Calculate how long it takes to fill the pool.
Give your answer in hours and minutes.

Answer(b)(i) hours minutes [2]

- (ii) Change 61 500 litres to gallons.
[4.55 litres = 1 gallon.]

Answer(b)(ii) gallons [1]

- (iii) Every 10 000 **gallons** of water needs 2.5 litres of purifier.
How many litres of purifier does Jon use for this pool?

Answer(b)(iii) litres [2]

- (iv) The purifier is sold in 1 litre bottles.
How many **bottles** of purifier must Jon buy for this pool?

Answer(b)(iv) [1]

7 (a)

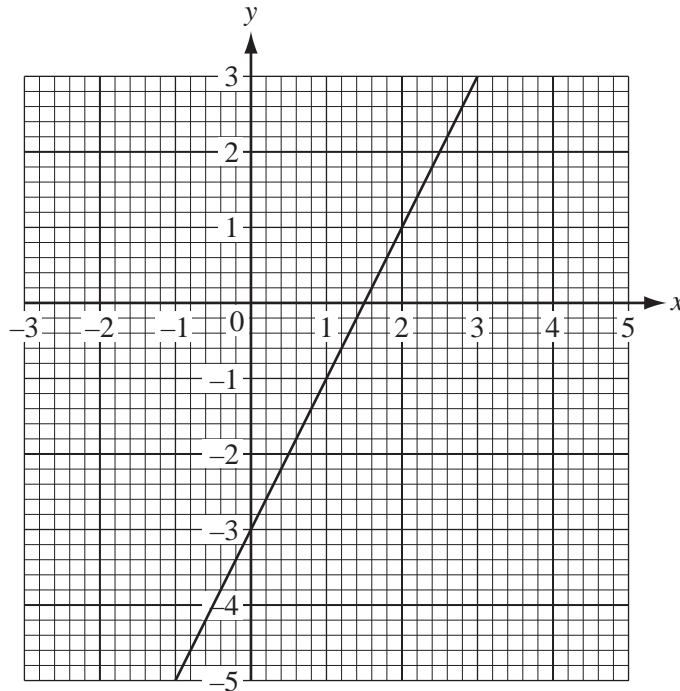

The simultaneous equations $2x - y = 3$ and $x + y = 2$ can be solved graphically.

(i) Which of these equations is shown by the line on the grid above?

Answer(a)(i) [1]

(ii) Find the gradient of the line on the grid.

Answer(a)(ii) [2]

(iii) Complete the table below for the other equation.

x	-1	0	1	2	3
y					

[2]

(iv) Draw this line on the grid above.

[1]

(v) Use your graphs to write down the solution to the two equations.

Give your values correct to 1 decimal place.

Answer(a)(v) $x =$

$y =$ [3]

- (b) Use algebra to solve the following simultaneous equations exactly.
Show all your working.

$$\begin{aligned} 2x - y &= 3, \\ x + y &= 2. \end{aligned}$$

For
Examiner's
Use

Answer(b) $x = \dots\dots\dots$

$y = \dots\dots\dots$ [4]

- 8 The diagram below shows a sequence of patterns made from dots and lines.

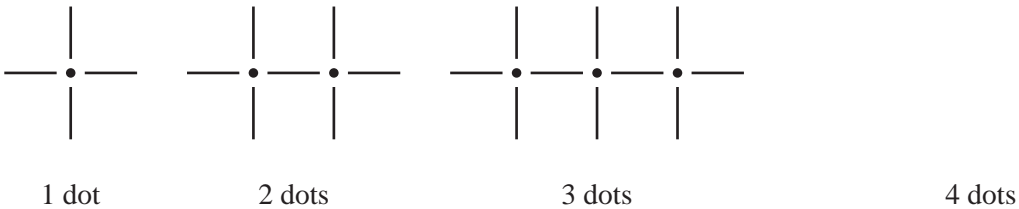

- (a) Draw the next pattern in the sequence in the space above. [1]
(b) Complete the table for the numbers of dots and lines.

Dots	1	2	3	4	5	6
Lines	4	7	10			

[2]

- (c) How many lines are in the pattern with 99 dots?

Answer(c) $\dots\dots\dots$ [2]

- (d) How many lines are in the pattern with n dots?

Answer(d) $\dots\dots\dots$ [2]

- (e) Complete the following statement.

There are 85 lines in the pattern with $\dots\dots\dots$ dots. [2]

- 9 (a) Calculate the size of one exterior angle of a regular heptagon (seven-sided polygon).
Give your answer correct to 1 decimal place.

Answer(a) [3]

(b)

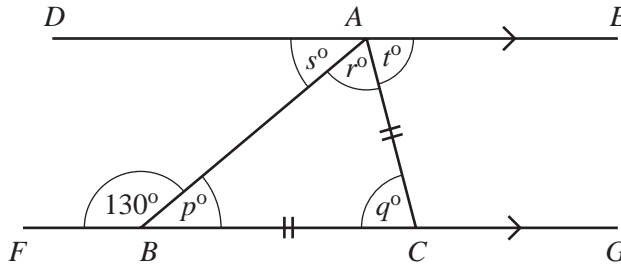

NOT TO
SCALE

In the diagram above, DAE and $FBCG$ are parallel lines.
 $AC = BC$ and angle $FBA = 130^\circ$.

- (i) What is the special name given to triangle ABC ?

Answer(b)(i) [1]

- (ii) Work out the values of p , q , r , s and t .

Answer (b)(ii) $p = \dots\dots\dots q = \dots\dots\dots r = \dots\dots\dots s = \dots\dots\dots t = \dots\dots\dots$ [5]

(c)

J, K and L lie on a circle centre O .
 KOL is a straight line and angle $JKL = 65^\circ$.
Find the value of y .

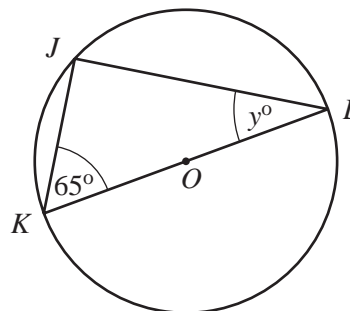

NOT TO
SCALE

Answer(c) $y = \dots\dots\dots$ [2]

Permission to reproduce items where third-party owned material protected by copyright is included has been sought and cleared where possible. Every reasonable effort has been made by the publisher (UCLES) to trace copyright holders, but if any items requiring clearance have unwittingly been included, the publisher will be pleased to make amends at the earliest possible opportunity.

University of Cambridge International Examinations is part of the University of Cambridge Local Examinations Syndicate (UCLES), which is itself a department of the University of Cambridge.