



UNIVERSITY OF CAMBRIDGE INTERNATIONAL EXAMINATIONS
International General Certificate of Secondary Education

CANDIDATE
NAME

CENTRE
NUMBER

--	--	--	--	--

CANDIDATE
NUMBER

--	--	--	--	--

* 9 8 7 1 9 8 5 0 6 7 *

MATHEMATICS

0581/22

Paper 2 (Extended)

May/June 2012

1 hour 30 minutes

Candidates answer on the Question Paper.

Additional Materials:

Electronic calculator
Mathematical tables (optional)

Geometrical instruments
Tracing paper (optional)

READ THESE INSTRUCTIONS FIRST

Write your Centre number, candidate number and name on all the work you hand in.

Write in dark blue or black pen.

You may use a pencil for any diagrams or graphs.

Do not use staples, paper clips, highlighters, glue or correction fluid.

DO NOT WRITE IN ANY BARCODES.

Answer **all** questions.

If working is needed for any question it must be shown below that question.

Electronic calculators should be used.

If the degree of accuracy is not specified in the question, and if the answer is not exact, give the answer to three significant figures. Give answers in degrees to one decimal place.

For π , use either your calculator value or 3.142.

At the end of the examination, fasten all your work securely together.

The number of marks is given in brackets [] at the end of each question or part question.

The total of the marks for this paper is 70.

This document consists of **12** printed pages.



- 1 The ferry from Helsinki to Travemunde leaves Helsinki at 17 30 on a Tuesday.
The journey takes 28 hours 45 minutes.

Work out the day and time that the ferry arrives in Travemunde.

Answer Day Time [2]

2

TRIGONOMETRY

From the above word, write down the letters which have

- (a) exactly two lines of symmetry,

Answer(a) [1]

- (b) rotational symmetry of order 2.

Answer(b) [1]

- 3 For this question, $1 < x < 2$.

Write the following in order of size, **smallest** first.

$$\frac{5}{x} \quad 5x \quad \frac{x}{5} \quad x - 5$$

Answer < < < [2]

4

$$1\frac{1}{2} + \frac{1}{3} + \frac{1}{4} = \frac{p}{12}$$

Work out the value of p .

Show all your working.

Answer $p =$ [2]

- 5 A lake has an area of 63 800 000 000 square metres.

Write this area in square kilometres, correct to 2 significant figures.

Answer km² [2]

- 6 x is a positive integer and $15x - 43 < 5x + 2$.

Work out the possible values of x .

Answer [3]

7

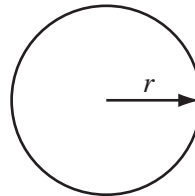
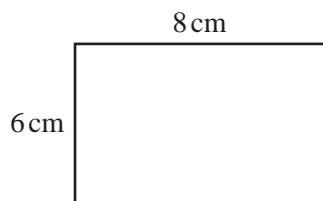

NOT TO
SCALE

The perimeter of the rectangle is the same length as the circumference of the circle.

Calculate the radius, r , of the circle.

Answer $r =$ cm [3]

For
Examiner's
Use

- 8 A car company sells a scale model $\frac{1}{10}$ of the size of one of its cars.

Complete the following table.

	Scale Model	Real Car
Area of windscreen (cm ²)	135	
Volume of storage space (cm ³)		408 000

[3]

9

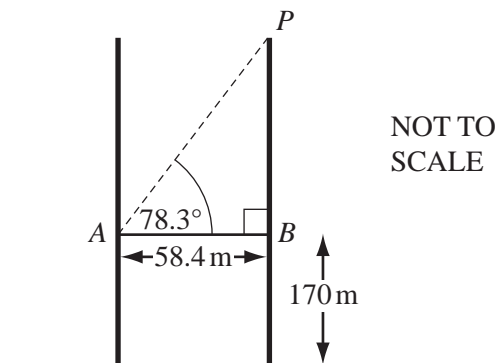

The line AB represents the glass walkway between the Petronas Towers in Kuala Lumpur. The walkway is 58.4 metres long and is 170 metres above the ground. The angle of elevation of the point P from A is 78.3° .

Calculate the height of P above the ground.

Answer m [3]

10

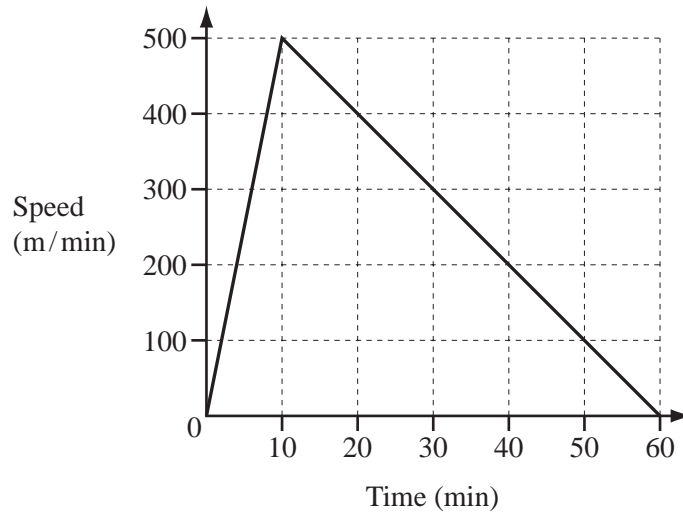

For
Examiner's
Use

The diagram shows the speed-time graph for a boat journey.

- (a) Work out the acceleration of the boat in metres/minute².

Answer(a) m/min² [1]

- (b) Calculate the total distance travelled by the boat.
Give your answer in **kilometres**.

Answer(b) km [2]

- 11 y varies directly as the square of $(x - 3)$.
 $y = 16$ when $x = 1$.

Find y when $x = 10$.

Answer $y =$ [3]

12

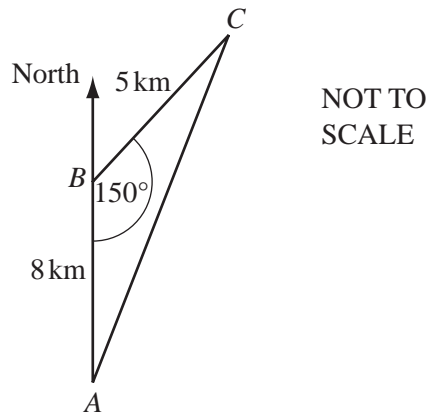

A helicopter flies 8 km due north from A to B . It then flies 5 km from B to C and returns to A .
 Angle $ABC = 150^\circ$.

- (a) Calculate the area of triangle ABC .

Answer(a) km^2 [2]

- (b) Find the bearing of B from C .

Answer(b) [2]

13 The taxi fare in a city is \$3 **and** then \$0.40 for every kilometre travelled.

(a) A taxi fare is \$9.

How far has the taxi travelled?

Answer(a) km [2]

(b) Taxi fares cost 30% more at night.

How much does a \$9 daytime journey cost at night?

Answer(b) \$ [2]

14

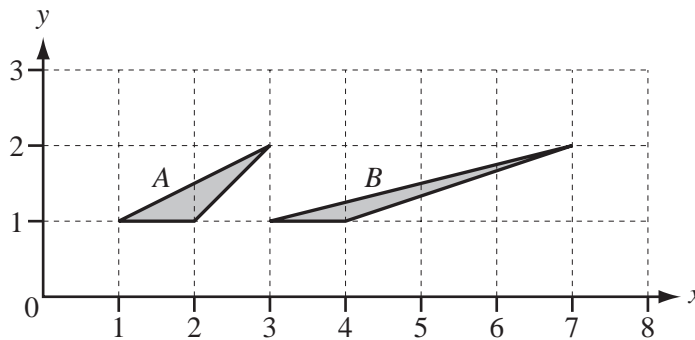

(a) Describe fully the **single** transformation that maps triangle *A* onto triangle *B*.

Answer(a) [3]

(b) Find the 2×2 matrix which represents this transformation.

Answer(b) $\left(\begin{array}{cc} & \\ & \end{array} \right)$ [2]

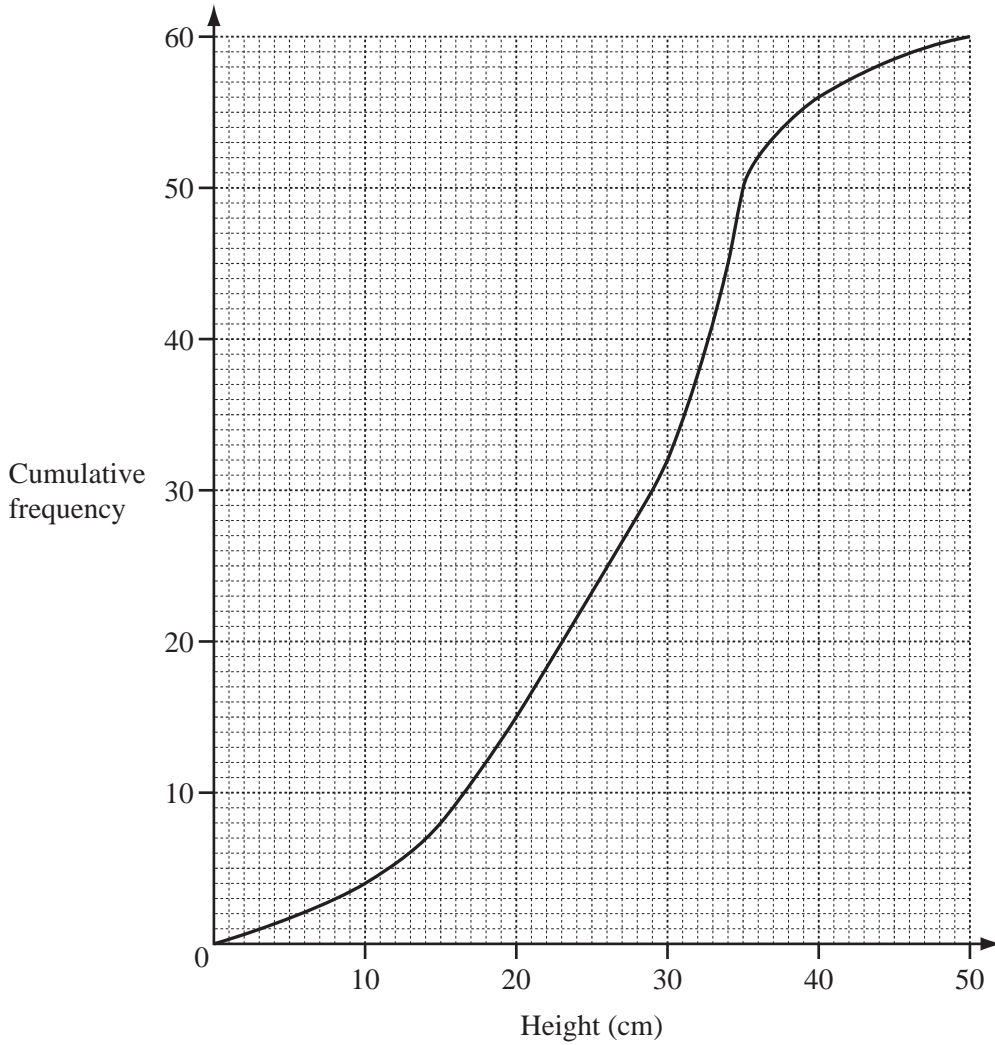

The cumulative frequency diagram shows information about the heights of 60 tomato plants. Use the diagram to find

(a) the median,

Answer(a) cm [1]

(b) the lower quartile,

Answer(b) cm [1]

(c) the interquartile range,

Answer(c) cm [1]

(d) the probability that the height of a tomato plant, chosen at random, will be more than 15 cm.

Answer(d) [2]

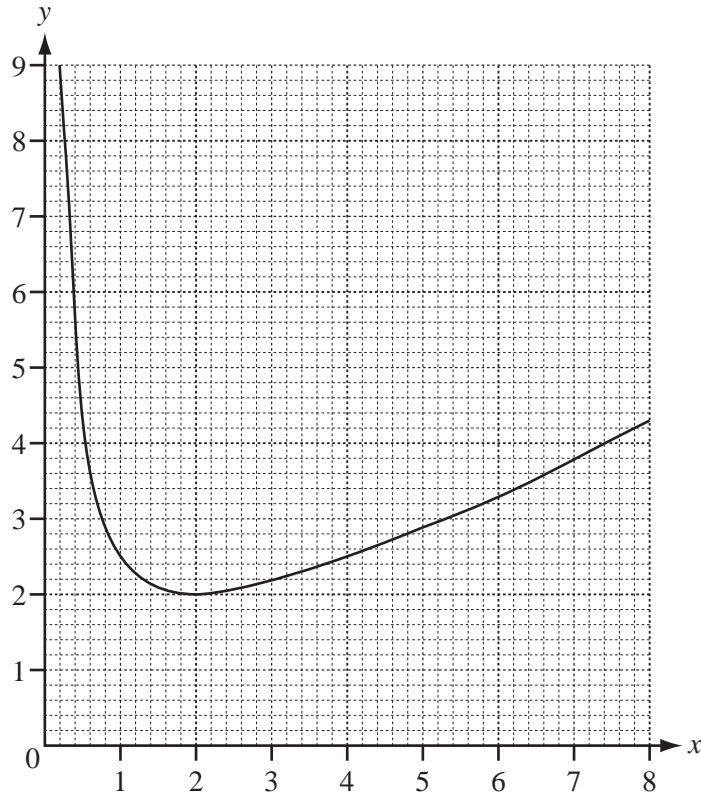

The diagram shows the graph of $y = \frac{x}{2} + \frac{2}{x}$, for $0 < x \leq 8$.

(a) Use the graph to solve the equation $\frac{x}{2} + \frac{2}{x} = 3$.

Answer (a) $x =$ or $x =$ [2]

(b) By drawing a suitable tangent, work out an estimate of the gradient of the graph where $x = 1$.

Answer(b) [3]

- 17 (a) Find the co-ordinates of the midpoint of the line joining $A(-8, 3)$ and $B(-2, -3)$.

For
Examiner's
Use

Answer(a) (..... ,) [2]

- (b) The line $y = 4x + c$ passes through $(2, 6)$.

Find the value of c .

Answer(b) $c =$ [1]

- (c) The lines $5x = 4y + 10$ and $2y = kx - 4$ are parallel.

Find the value of k .

Answer(c) $k =$ [2]

18

$f(x) = (x + 2)^3 - 5$

$g(x) = 2x + 10$

$h(x) = \frac{1}{x}, x \neq 0$

For
Examiner's
Use

Find

(a) $gf(x)$,

Answer(a) $gf(x) = \dots\dots\dots$ [2]

(b) $f^{-1}(x)$,

Answer(b) $f^{-1}(x) = \dots\dots\dots$ [3]

(c) $gh(-\frac{1}{5})$.

Answer(c) $\dots\dots\dots$ [2]

Question 19 is printed on the next page.

19 Find the values of x for which

(a) $\begin{pmatrix} 1 & 0 \\ 0 & 2x-7 \end{pmatrix}$ has no inverse,

Answer(a) $x = \dots\dots\dots$ [2]

(b) $\begin{pmatrix} 1 & 0 \\ 0 & x^2-8 \end{pmatrix}$ is the identity matrix,

Answer (b) $x = \dots\dots\dots$ or $x = \dots\dots\dots$ [3]

(c) $\begin{pmatrix} 1 & 0 \\ 0 & x-2 \end{pmatrix}$ represents a stretch with factor 3 and the x axis invariant.

Answer (c) $x = \dots\dots\dots$ [2]

For
Examiner's
Use

Permission to reproduce items where third-party owned material protected by copyright is included has been sought and cleared where possible. Every reasonable effort has been made by the publisher (UCLES) to trace copyright holders, but if any items requiring clearance have unwittingly been included, the publisher will be pleased to make amends at the earliest possible opportunity.

University of Cambridge International Examinations is part of the Cambridge Assessment Group. Cambridge Assessment is the brand name of University of Cambridge Local Examinations Syndicate (UCLES), which is itself a department of the University of Cambridge.