



UNIVERSITY OF CAMBRIDGE INTERNATIONAL EXAMINATIONS
International General Certificate of Secondary Education

CANDIDATE
NAME

CENTRE
NUMBER

--	--	--	--	--

CANDIDATE
NUMBER

--	--	--	--

MATHEMATICS

0581/13

Paper 1 (Core)

May/June 2010

1 hour

Candidates answer on the Question Paper.

Additional Materials:

Electronic Calculator
Geometrical Instruments

Mathematical tables (optional)
Tracing paper (optional)

READ THESE INSTRUCTIONS FIRST

Write your Centre number, candidate number and name on all the work you hand in.

Write in dark blue or black pen.

You may use a pencil for any diagrams or graphs.

Do not use staples, paper clips, highlighters, glue or correction fluid.

DO NOT WRITE IN ANY BARCODES.

Answer **all** questions.

If working is needed for any question it must be shown below that question.

Electronic calculators should be used.

If the degree of accuracy is not specified in the question, and if the answer is not exact, give the answer to three significant figures. Give answers in degrees to one decimal place.

For π , use either your calculator value or 3.142.

At the end of the examination, fasten all your work securely together.

The number of marks is given in brackets [] at the end of each question or part question.

The total of the marks for this paper is 56.

This document consists of **11** printed pages and **1** blank page.

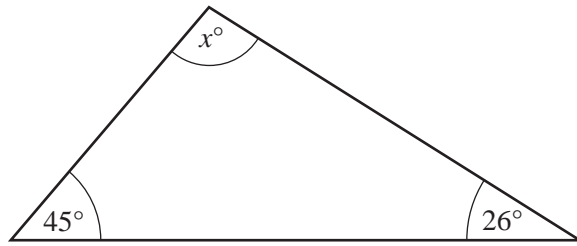

1

NOT TO
SCALEFind the value of x .

Answer $x =$ [1]

- 2 A train to Paris leaves at 06 30.
The journey takes 3 hours and 56 minutes.

Work out the time when the train arrives in Paris.

Answer [1]

- 3 Write down the factors of 48 which are between 10 and 40.

Answer [2]

4 < = >

For each part, choose a symbol from those above to make a correct statement.

(a) $\frac{5}{9}$ 0.55 [1]

(b) 66% $\frac{2}{3}$ [1]

5 In a sale, the price of a boat was reduced from \$21 000 to \$16 800.

Calculate the reduction as a percentage of the original price.

Answer % [2]

6 Write down the equation of the line, parallel to $y = 3x + 5$, which passes through the point $(0, -2)$.

Answer [2]

- 7 Mrs Duval makes one litre of ice cream.
She eats $\frac{1}{8}$ litre and her children eat $\frac{3}{5}$ litre.

Without using your calculator, find what fraction of a litre of ice cream is left.
Show all your working clearly.

Answer [2]

- 8 (a) Use your calculator to work out $27.4 \times (3.28 + 1.6 \times 9.8)$.

Write down all the figures from your calculator display.

Answer(a) [1]

- (b) Write your answer to **part (a)** correct to 3 significant figures.

Answer(b) [1]

- 9 Calculate the area of a circle of radius 3.75 cm.

Answer cm² [2]

10 (a)

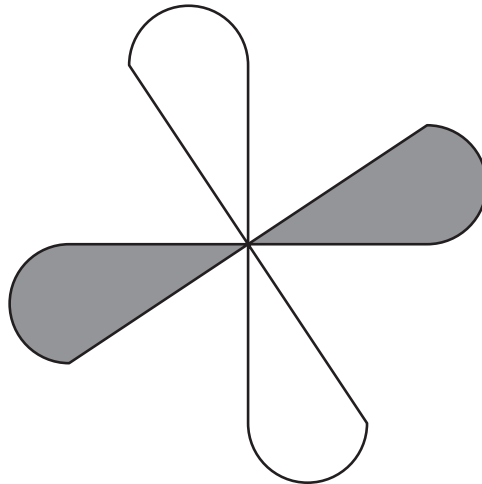

Write down the order of rotational symmetry of the shape above.

Answer(a) [1]

(b)

A M N O T X

From the list, write down the letters which have only **one** line of symmetry.

Answer(b) [2]

11 Simplify

(a) $m^3 \times m^{-5}$,

Answer(a) [1]

(b) $15k^8 \div 3k^2$.

Answer(b) [2]

12

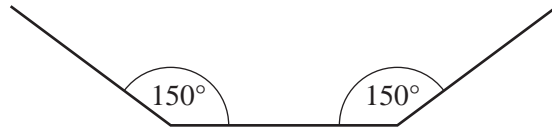
NOT TO
SCALE

The diagram shows part of a regular polygon with each interior angle 150° .

Calculate the number of sides of the polygon.

Answer [3]

13 Expand the following expressions.

(a) $5(3 - 4h)$

Answer(a) [1]

(b) $4d(6d^2 + e^2)$

Answer(b) [2]

For
Examiner's
Use

14

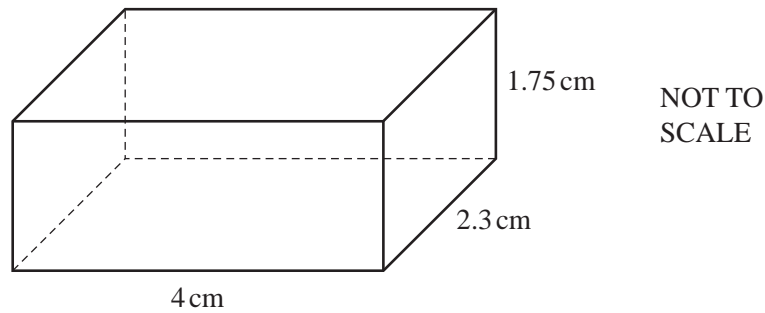

The cuboid above has length 4 cm, width 2.3 cm and height 1.75 cm.

Calculate the volume of the cuboid

(a) in cubic centimetres,

Answer(a) cm^3 [2]

(b) in cubic millimetres.

Answer(b) mm^3 [1]

15 Simplify the following expressions.

(a) $6r + 2s + s - 4r$

Answer(a) [1]

(b) $4f^2 - 3g + 4g - 9f^2$

Answer(b) [2]

16

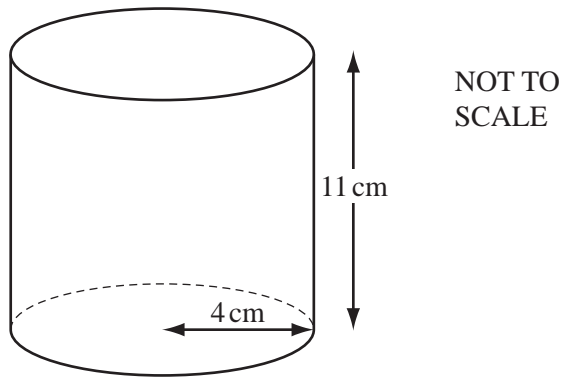

A cylindrical can of beans has height 11 cm and radius 4 cm.
A label covers the curved surface of the can completely.

Calculate the area of the label.

Answer cm² [3]

17 Solve the simultaneous equations.

$$\begin{aligned} 3x + y &= 19 \\ 5x - y &= 13 \end{aligned}$$

Answer $x =$

$y =$ [3]

18

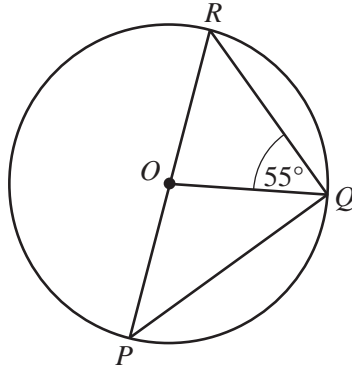
NOT TO
SCALEFor
Examiner's
Use

P , Q and R lie on a circle, centre O .
 PR is a diameter and angle $OQR = 55^\circ$.

Find

(a) angle PQR ,Answer(a) Angle $PQR = \dots\dots\dots$ [1](b) angle ROQ ,Answer(b) Angle $ROQ = \dots\dots\dots$ [1](c) angle OPQ .Answer(c) Angle $OPQ = \dots\dots\dots$ [1]

19

$$\mathbf{f} = \begin{pmatrix} 6 \\ 0 \end{pmatrix}$$

$$\mathbf{g} = \begin{pmatrix} -3 \\ 6 \end{pmatrix}$$

$$\mathbf{h} = \begin{pmatrix} 2 \\ -2 \end{pmatrix}$$

Calculate

(a) $3\mathbf{f}$,

Answer(a) $\begin{pmatrix} \\ \end{pmatrix}$ [2]

(b) $\mathbf{g} - \mathbf{h}$.

Answer(b) $\begin{pmatrix} \\ \end{pmatrix}$ [2]

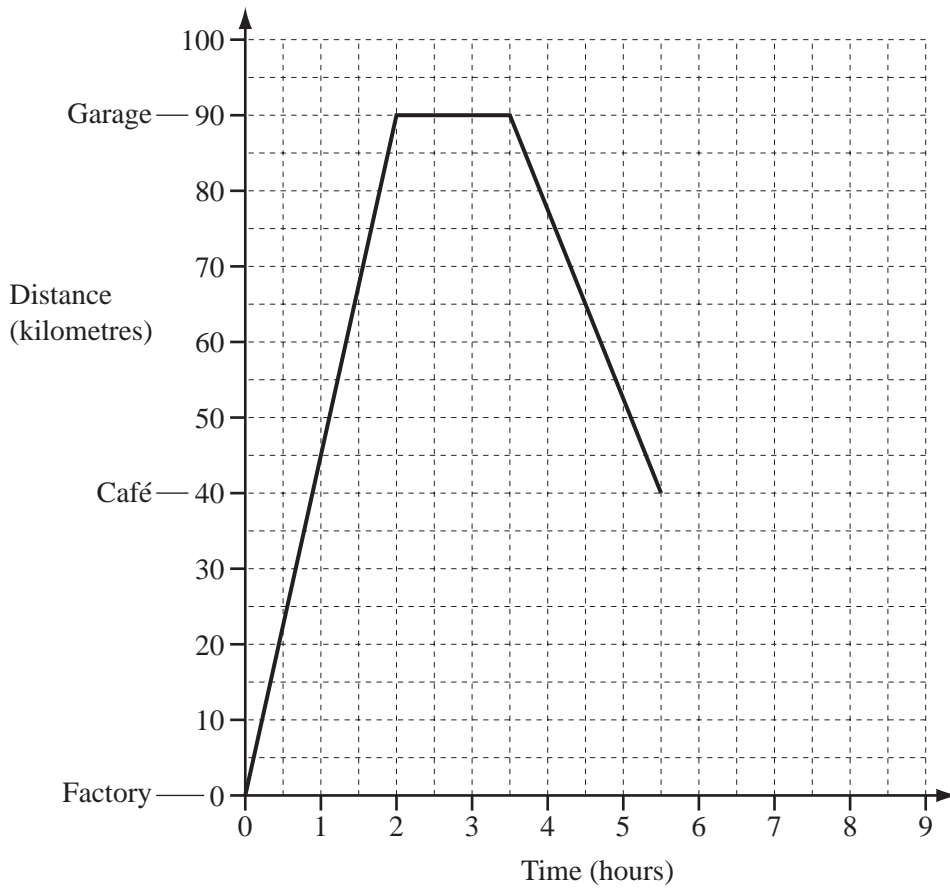

The travel graph shows part of the journey of a truck driver.
 The driver leaves a factory to deliver tyres to a garage.
 After unloading the tyres, the driver returns to the factory, but stops at a café for 1 hour.
 He then completes the journey at an average speed of 80 km/h.

(a) Calculate the average speed of the truck on its journey from the factory to the garage.

Answer(a) km/h [1]

(b) Write down the length of time the truck stays at the garage.

Answer(b) hours [1]

(c) Complete the travel graph. [2]

21

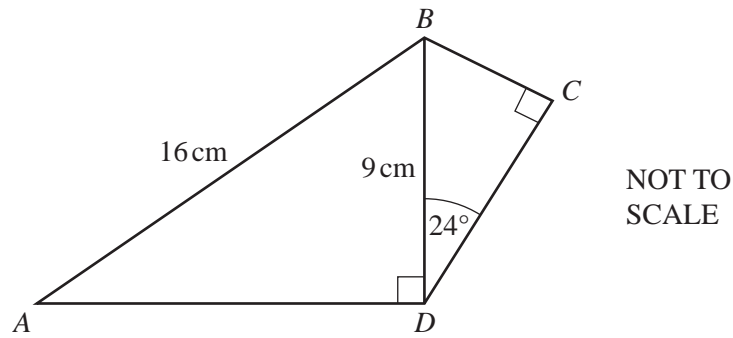
For
Examiner's
Use

The diagram shows a quadrilateral $ABCD$.
 $AB = 16$ cm, $BD = 9$ cm and angle $BDC = 24^\circ$.
 Angle $ADB = 90^\circ =$ angle BCD .

Calculate the length of

(a) AD ,

Answer(a) $AD =$ cm [3]

(b) CD .

Answer(b) $CD =$ cm [2]

BLANK PAGE

Permission to reproduce items where third-party owned material protected by copyright is included has been sought and cleared where possible. Every reasonable effort has been made by the publisher (UCLES) to trace copyright holders, but if any items requiring clearance have unwittingly been included, the publisher will be pleased to make amends at the earliest possible opportunity.

University of Cambridge International Examinations is part of the Cambridge Assessment Group. Cambridge Assessment is the brand name of University of Cambridge Local Examinations Syndicate (UCLES), which is itself a department of the University of Cambridge.