



UNIVERSITY OF CAMBRIDGE INTERNATIONAL EXAMINATIONS
International General Certificate of Secondary Education

CANDIDATE
NAME

CENTRE
NUMBER

--	--	--	--

CANDIDATE
NUMBER

--	--	--	--



GEOGRAPHY

0460/43

Paper 4 Alternative to Coursework

October/November 2012

1 hour 30 minutes

Candidates answer on the Question Paper.

Additional Materials: Ruler
 Calculator

READ THESE INSTRUCTIONS FIRST

Write your Centre number, candidate number and name in the spaces provided.

Write in dark blue or black pen.

You may use a soft pencil for any diagrams, graphs or rough working.

Do not use staples, paper clips, highlighters, glue or correction fluid.

DO NOT WRITE ON ANY BARCODES.

Answer **all** questions.

The Insert contains Figs 1, 2 and 3 and Table 2 for Question 1, and Figs 6 and 10 and Table 5 for Question 2.

The Insert is **not** required by the Examiner.

Sketch maps and diagrams should be drawn whenever they serve to illustrate an answer.

At the end of the examination, fasten all your work securely together.

The number of marks is given in brackets [] at the end of each question or part question.

For Examiner's Use	
Q1	
Q2	
Total	

This document consists of **16** printed pages and **1** Insert.



- 1 A geography student was studying local weather conditions. He decided to do an investigation of rainfall and wind direction at his school and at a coastguard station about 60 km away. The locations of the school and coastguard station are shown on Fig. 1 (Insert).

He tested the following hypotheses:

Hypothesis 1: *There is more daily rainfall at school than at the coastguard station.*

Hypothesis 2: *There is more rainfall on days when the wind is blowing from the south and south west.*

- (a) To investigate the two hypotheses the student used a rain gauge and a wind vane. These are shown in Figs 2 and 3 (Insert).

- (i) Suggest **two** factors which the student should have considered when deciding where to put the rain gauge.

1

.....

2

..... [2]

- (ii) Describe how the student would have used the rain gauge to make his measurements.

.....

.....

.....

.....

.....

..... [3]

- (iii) The student used a wind vane to observe wind direction. Suggest a good location to put the wind vane and explain your choice.

.....

.....

.....

..... [2]

- (iv) Explain how a wind vane shows wind direction.

For
Examiner's
Use

.....

.....

.....

.....

.....

.....

.....[3]

- (b) The student recorded the results of his measurements in a fieldwork diary which is shown in Table 1 below.

Table 1

Fieldwork diary from school

Date	Time measurements taken	Rainfall (mm)	Wind direction
Monday 11th	09.00	2	South
Tuesday 12th	09.00	5	South west
Wednesday 13th	10.00	1	South
Thursday 14th	09.00	5	South west
Friday 15th	09.30	2	South east
Saturday 16th	Not taken		
Sunday 17th	Not taken		
Monday 18th	11.00	8	North
Tuesday 19th	Not taken		
Wednesday 20th	Not taken		
Thursday 21st	09.00	12	North west
Friday 22nd	09.30	6	North
Saturday 23rd	Not taken		
Sunday 24th	Not taken		
Monday 25th	14.00	3	South
Tuesday 26th	10.00	4	South
Average (mean) daily rainfall			

- (i) Calculate the average (mean) daily rainfall for the 10 days in which measurements were taken. Insert your answer into Table 1. [1]

- (ii) The student obtained secondary weather data for the same period of time from the coastguard station. This is shown in Table 2 (Insert).

Often students get both primary and secondary data to investigate a hypothesis. Complete the table below which shows both types of data, by putting the following methods under the correct heading.

Researching on the internet

Measuring the speed of river flow

Using a barometer

Reading a newspaper report

[2]

Primary data	Secondary data
Doing a pedestrian count	Using an atlas map

- (iii) Suggest **two** ways in which the secondary data obtained from the coastguard station is more reliable than the primary data collected by the student.

1

.....

2

..... [2]

- (iv) To compare the rainfall amounts at the school and the coastguard station the student plotted both sets of data onto a dispersion graph, Fig. 4 below.

For
Examiner's
Use

From Table 2 (Insert) add data to the dispersion graph to show the amount of rainfall at the coastguard station on Saturday 23rd. [1]

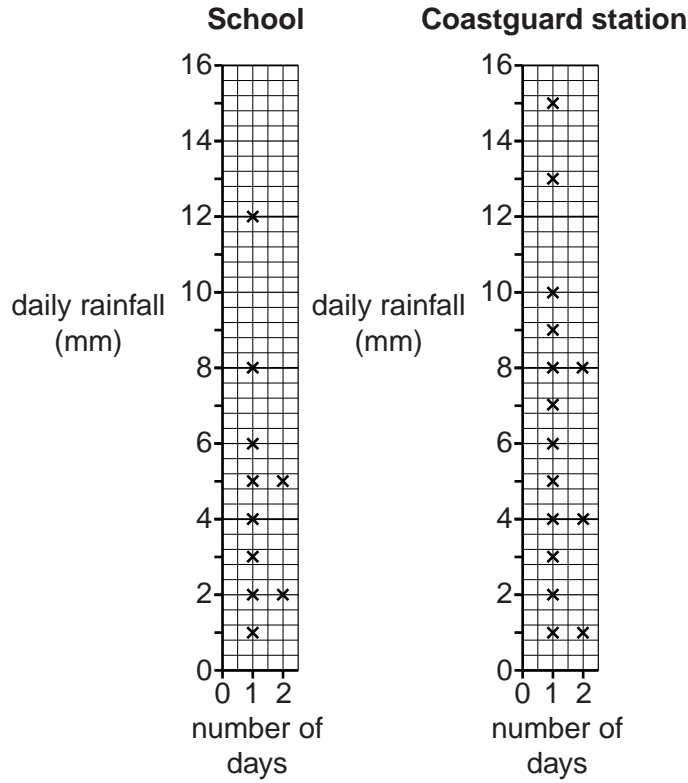

Fig. 4

- (v) The student decided that **Hypothesis 1: There is more daily rainfall at school than at the coastguard station** was false. What evidence from Tables 1 and 2 and Fig. 4 supports his conclusion?

.....

.....

.....

.....

.....

.....

..... [3]

(c) To help him to reach a conclusion about **Hypothesis 2**: *There is more rainfall on days when the wind is blowing from the south and south west, the student drew two graphs to compare wind direction and rainfall amounts. These are shown in Figs 5A and 5B below and opposite.*

For
Examiner's
Use

Wind direction and rainfall amounts at school

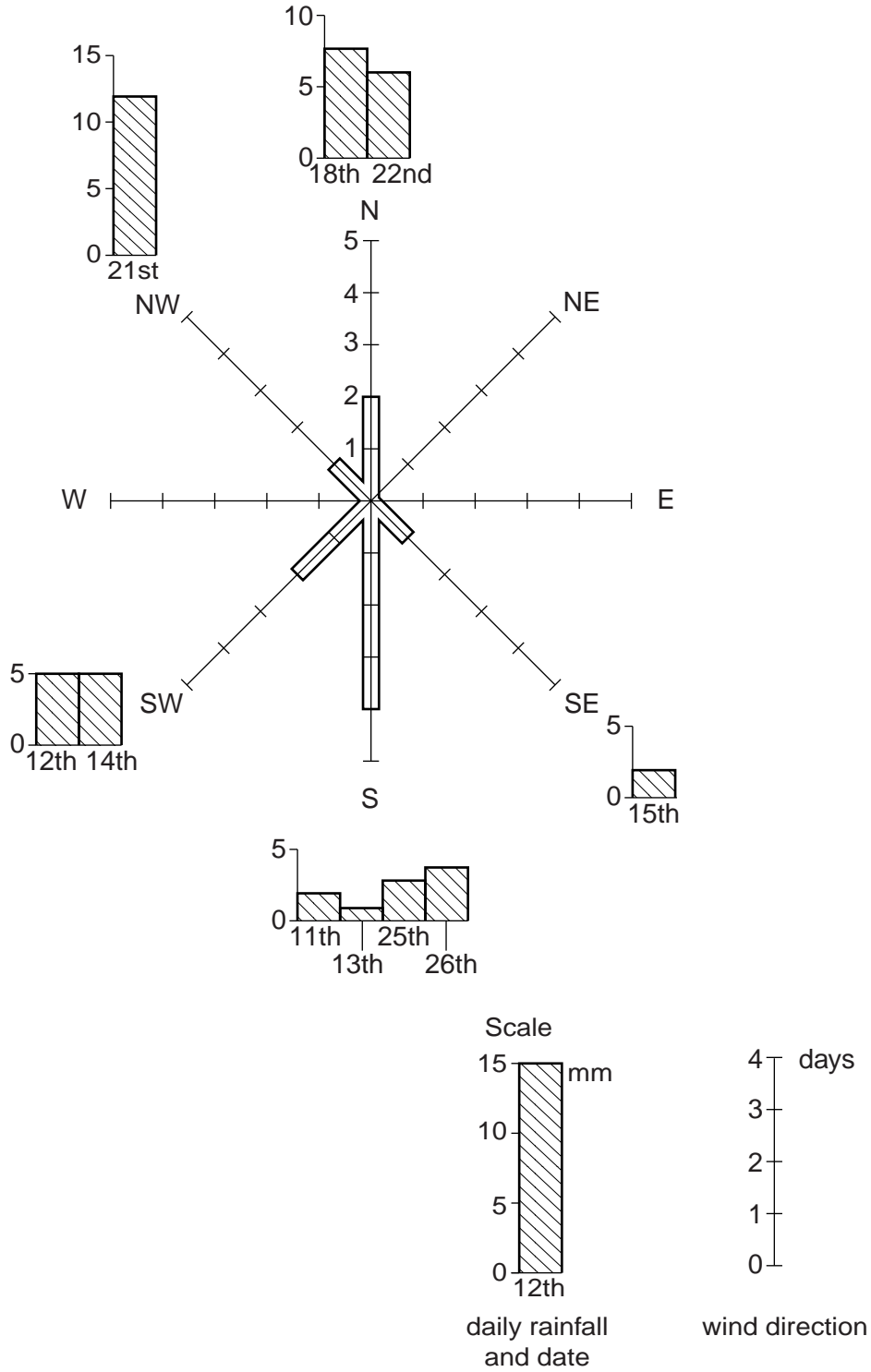

Fig. 5A

Wind direction and rainfall amounts at coastguard station

For
Examiner's
Use

Fig. 5B

- (i) Use the results in Table 2 (Insert) to draw onto Fig. 5B the SW wind direction bar at the coastguard station. Use the scale below Fig. 5A. [1]
- (ii) Use the results in Table 2 to draw onto Fig. 5B the rainfall bar for Friday 15th. Use the scale below Fig. 5A. [3]

- (iii) For the two places he studied, what conclusion would the student make about **Hypothesis 2**: *There is more rainfall on days when the wind is blowing from the south and south west?* Support your answer with evidence from Figs 5A and 5B.

At school (Fig. 5A)

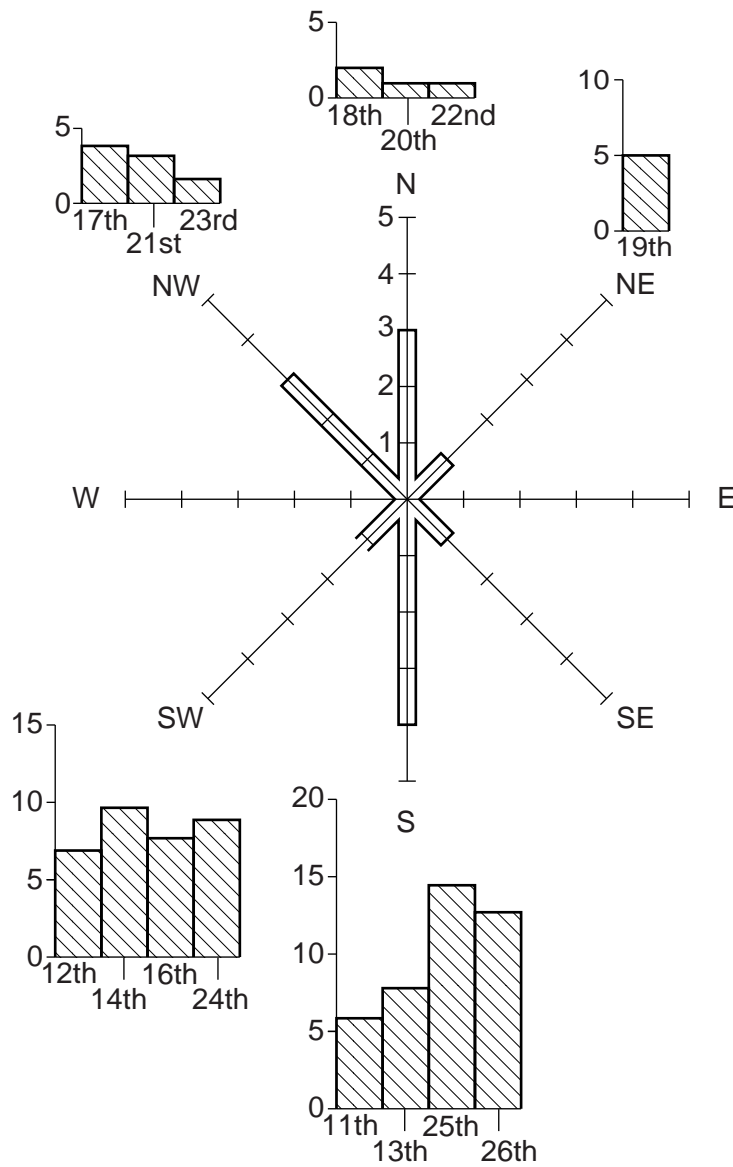
.....
.....
.....
.....

At the coastguard station (Fig. 5B)

.....
.....
.....
..... [4]

- (d) Suggest why daily rainfall **amounts** vary between the school and the coastguard station. Use Fig. 1 (Insert) to help you to answer.

.....
.....
.....
.....
.....
..... [3]

[Total: 30 marks]

- 2 Students who lived in Southern Thailand were interested in the effects of tourism in their local town, Hua Hin. They decided to investigate the environmental and economic effects of tourism in different areas of the town.

They agreed on the following hypotheses:

Hypothesis 1: *Tourism has a negative impact on the environment of Hua Hin.*

Hypothesis 2: *Tourism has an economic benefit for the residents of Hua Hin.*

- (a) To carry out their fieldwork the students identified ten survey sites in the town. These are shown on Fig. 6 (Insert). At each site the students wanted to estimate the importance of tourism. They based their decision on whether shops in the area were used mainly by local people or tourists.

- (i) Suggest **three** ways that they could decide whether shops were used mainly by local people or tourists.

1

.....

2

.....

3

..... [3]

- (ii) Before starting their fieldwork the students did a small pilot (trial) survey near their school. Give **two** advantages of doing a pilot survey.

1

.....

2

..... [2]

(iii) The results of the students' fieldwork are shown in Table 3, below.

Use these results to complete the divided bar for site 5 on Fig. 7 below.

For
Examiner's
Use [2]

Table 3
Results of fieldwork

	Pilot site	Survey sites									
		1	2	3	4	5	6	7	8	9	10
Number of shops used mainly by local people	8	7	7	10	8	6	2	5	7	2	1
Number of shops used mainly by tourists	3	1	2	8	8	9	12	10	11	10	12

Results of fieldwork

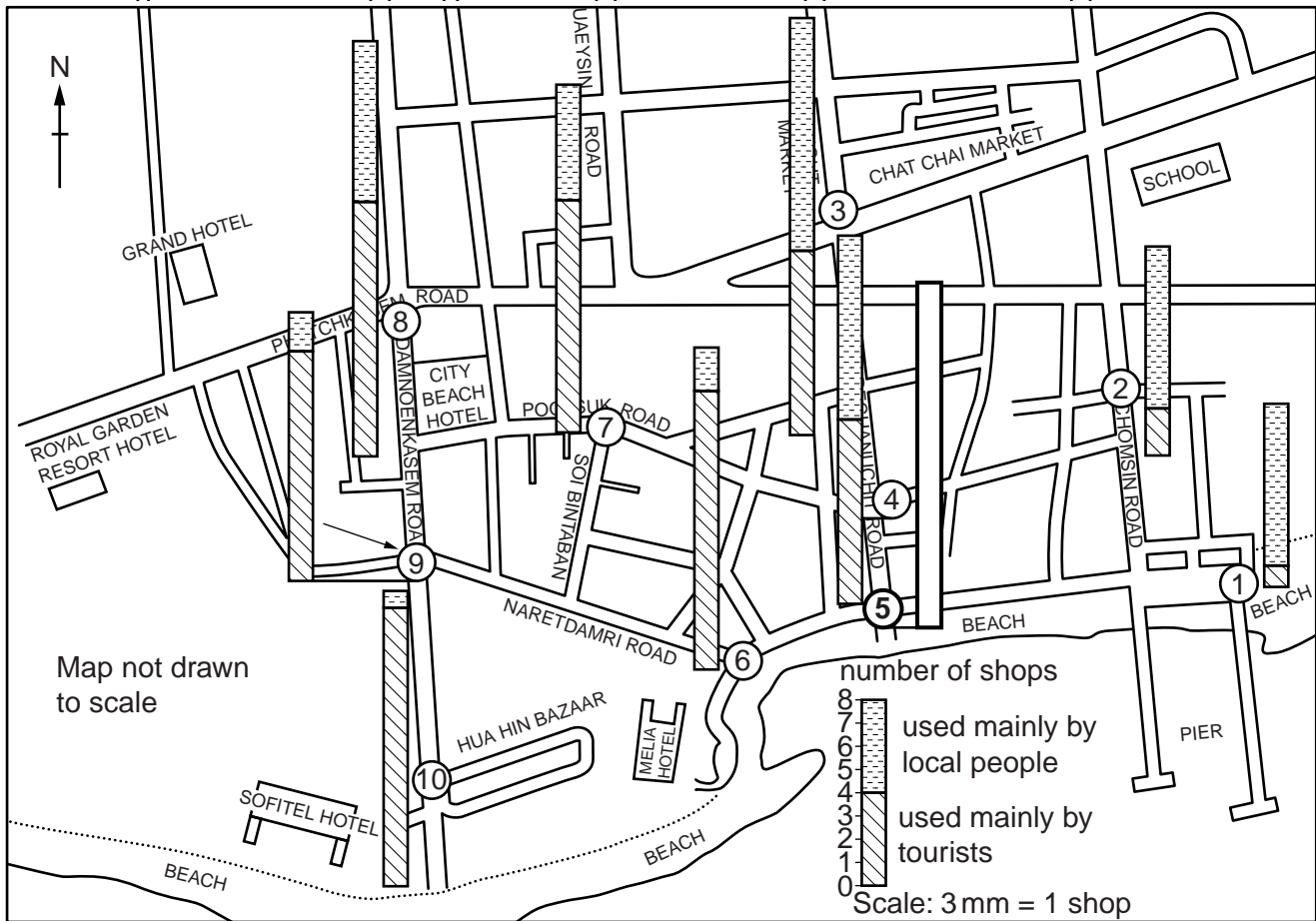

Fig. 7

- (iv) The students then decided to rank the ten sites in order of importance for tourism. To do this they first calculated the percentage of shops used mainly by tourists at each site using the following formula:

$$\frac{\text{number of shops used mainly by tourists}}{\text{total number of shops}} \times 100$$

The number of shops at the pilot survey site is shown in Table 3. In the space below calculate the percentage of shops at this site used mainly by tourists. Show your calculation. [2]

Pilot site

- (v) The results of this calculation for the ten actual survey sites are shown in Table 4 below. Complete the rank order of the percentage of shops used mainly by tourists by inserting ranks 1 to 5. [1]

Table 4

Percentage of shops used mainly by tourists

Survey site	1	2	3	4	5	6	7	8	9	10
Percentage of shops used mainly by tourists	12.5	22.2	44.4	50.0	60.0	85.7	66.7	61.1	83.3	92.3
Rank order	10	9	8	7	6					

(b) Having decided how important tourism was at the ten sites, the students then did an environmental quality survey at each site. The scoring chart which they used for the pilot survey is shown in Fig. 8 below. The students' decisions are circled.

For
Examiner's
Use

Environmental quality survey recording sheet

Pilot survey site near school					
Very little litter	4	3	2	①	Lots of litter
Very quiet	4	3	②	1	Very noisy
Unpolluted air	4	③	2	1	Polluted air
Very little traffic	4	3	②	1	Lots of traffic
Lots of vegetation	4	3	2	①	Very little vegetation
Well maintained buildings	4	3	②	1	Buildings in very poor condition
Very safe for pedestrians	4	③	2	1	Very dangerous for pedestrians

Total environmental score =

Fig. 8

(i) Calculate the total environmental score for the pilot survey site and insert your answer in the box below Fig. 8. [1]

(ii) Give **two** possible weaknesses of an environmental quality survey.

- 1
-
- 2
- [2]

- (iii) The two sets of results for percentage of shops used mainly by tourists and environmental score at the ten sites are shown in Table 5 (Insert). Plot the results for sites 4 and 7 on the scatter graph, Fig. 9, below. [2]



Fig. 9

- (iv) Draw a best-fit line on Fig. 9. [1]

- (v) The students rejected **Hypothesis 1: Tourism has a negative impact on the environment of Hua Hin.** Give one piece of evidence from Fig. 9 to explain why they rejected the hypothesis.

.....
 [1]

- (vi) Suggest **two** reasons for the relationship shown in Fig. 9.

1

 2
 [2]

(c) To get data for **Hypothesis 2: Tourism has an economic benefit for the residents of Hua Hin** the students used a questionnaire. At each site they questioned 20 people. The questionnaire which they used is shown in Fig. 10 (Insert).

(i) How would the students use a systematic sampling technique with their questionnaire?

.....
 [1]

(ii) The results of Question 2 obtained from 20 residents at site 3 are shown below.

Q2 Overall do you think tourism has an economic benefit in Hua Hin?

Yes	11
No	9

Plot these results on Fig. 11 below.

[1]

Questionnaire results for Question 2

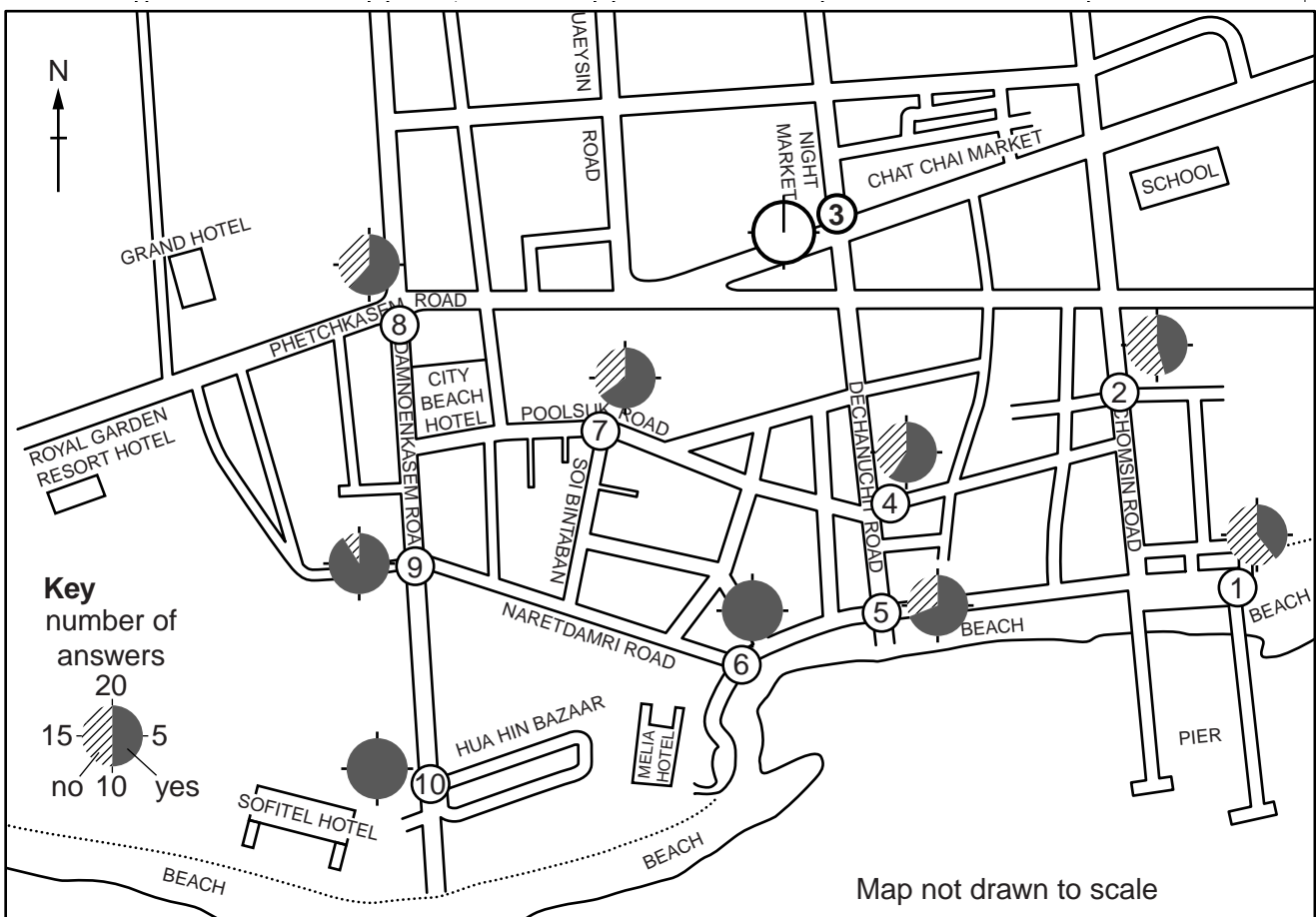

Fig. 11

(iii) The results of Question 3 obtained from 20 residents at site 3 are shown below.

Q3 What do you think is the main benefit of tourism in Hua Hin?

More job opportunities	6
Improved standard of living	5
Improved infrastructure	3
Greater range of goods in shops	3
More modern services	3

Plot these results onto the tally chart, Fig. 12 below.

[2]

Results of survey

Site	More job opportunities	Improved standard of living	Improved infrastructure	Greater range of goods in shops	More modern services
1	////	///	///	////	## /
2	///	////	//	##	## /
3					
4	## /	## /	//	////	//
5	## ////	////	/	//	///
6	## ##	##	/	//	//
7	## ////	////	//	///	//
8	## ##	##	//	/	//
9	## ## ///	////	/	/	/
10	## ## ##	////		/	

Fig. 12

(iv) What conclusion can you make about **Hypothesis 2: Tourism has an economic benefit for the residents of Hua Hin?** Support your answer with evidence from Figs 11 and 12.

.....
.....
.....
.....
.....
.....
.....
.....[4]

(d) Local people identified more job opportunities and an improved standard of living as the main benefits of tourism. Why are these the main benefits of tourism?

.....
.....
.....
.....
.....
.....[3]

[Total: 30 marks]

Permission to reproduce items where third-party owned material protected by copyright is included has been sought and cleared where possible. Every reasonable effort has been made by the publisher (UCLES) to trace copyright holders, but if any items requiring clearance have unwittingly been included, the publisher will be pleased to make amends at the earliest possible opportunity.

University of Cambridge International Examinations is part of the Cambridge Assessment Group. Cambridge Assessment is the brand name of University of Cambridge Local Examinations Syndicate (UCLES), which is itself a department of the University of Cambridge.