



Cambridge International Examinations
Cambridge International General Certificate of Secondary Education

CANDIDATE
NAME

CENTRE
NUMBER

--	--	--	--	--

CANDIDATE
NUMBER

--	--	--	--

* 0 1 2 3 4 5 6 7 8 9 *



CHEMISTRY

0620/04

Paper 4 Theory (Extended)

For Examination from 2016

SPECIMEN PAPER

1 hour 15 minutes

Candidates answer on the Question Paper.

No Additional Materials are required.

READ THESE INSTRUCTIONS FIRST

Write your Centre number, candidate number and name on all the work you hand in.

Write in dark blue or black pen.

You may use an HB pencil for any diagrams, graphs or rough working.

Do not use staples, paper clips, glue or correction fluid.

DO **NOT** WRITE IN ANY BARCODES.

Answer **all** questions.

Electronic calculators may be used.

You may lose marks if you do not show your working or if you do not use appropriate units.

A copy of the Periodic Table is printed on page 20.

At the end of the examination, fasten all your work securely together.

The number of marks is given in brackets [] at the end of each question or part question.

The syllabus is accredited for use in England, Wales and Northern Ireland as a Cambridge International Level 1/Level 2 Certificate.

This document consists of **18** printed pages and **2** blank pages.

1 The following table gives information about six substances.

substance	melting point / °C	boiling point / °C	electrical conductivity as a solid	electrical conductivity as a liquid
A	839	1484	good	good
B	-188	-42	poor	poor
C	776	1497	poor	good
D	-117	78	poor	poor
E	1607	2227	poor	poor
F	-5	102	poor	good

(a) Which substance could be a metal?

..... [1]

(b) State **all** the substances that are liquid at room temperature?

..... [1]

(c) Which substance could have a macromolecular structure similar to that of silicon(IV) oxide?

..... [1]

(d) Which substance could be propane?

..... [1]

(e) Which substance could be sodium chloride?

..... [1]

[Total: 5]

2 The table gives the composition of three particles.

particle	number of protons	number of electrons	number of neutrons
A	15	15	16
B	15	18	16
C	15	15	17

(a) What is the evidence in the table for each of the following?

(i) Particle **A** is an atom.

.....
 [1]

(ii) **A**, **B** and **C** are all particles of the same element.

.....
 [1]

(iii) Particles **A** and **C** are isotopes of the same element.

.....
 [2]

(b) (i) What is the electronic structure of particle **A**?

..... [1]

(ii) Is element **A**, a metal or a non-metal? Give a reason for your choice.

.....
 [1]

[Total: 6]

3 Kinetic theory explains the properties of matter in terms of the arrangement and movement of particles.

(a) Nitrogen is a gas at room temperature. Nitrogen molecules, N_2 , are spread far apart and move in a random manner at high speed.

(i) Draw the electronic structure of a nitrogen molecule.
Show only the outer electron shells.

[2]

(ii) Compare the movement and arrangement of the molecules in solid nitrogen to those in nitrogen gas.

.....
.....
.....
..... [3]

(b) A sealed container contains nitrogen gas. The pressure of the gas is due to the molecules of the gas hitting the walls of the container.
Use the kinetic theory to explain why the pressure inside the container increases when the temperature is increased.

.....
..... [2]

The following apparatus can be used to measure the rate of diffusion of a gas.

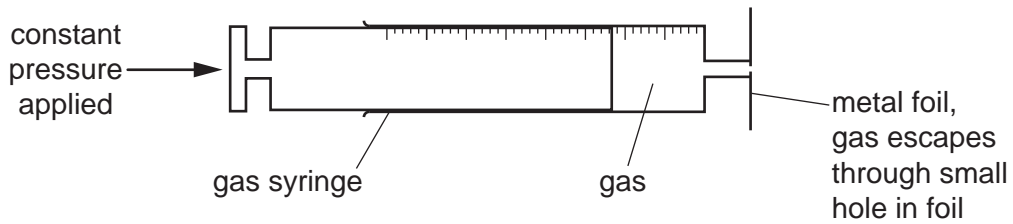

The following results were obtained.

gas	temperature / °C	rate of diffusion in cm ³ /min
nitrogen	25	1.00
chlorine	25	0.63
nitrogen	50	1.05

(c) (i) Explain why nitrogen gas diffuses faster than chlorine gas.

.....
 [2]

(ii) Explain why the nitrogen gas diffuses faster at the higher temperature.

..... [1]

[Total: 10]

4 Chromium is a transition element.

(a) (i) State **two** differences in the physical properties of chromium and sodium.

.....
 [2]

(ii) State **two** differences in the chemical properties of chromium and sodium.

.....

 [2]

(b) Chromium is used to electroplate steel objects. The diagram shows how this could be done.

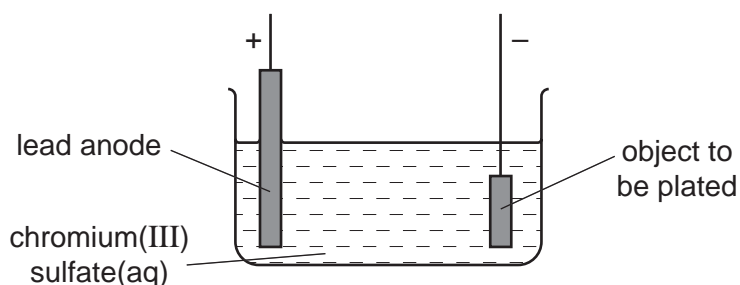

(i) Give **two** reasons why steel objects are plated with chromium.

.....
 [2]

(ii) The formula of the chromium(III) ion is Cr^{3+} and of the sulfate ion is SO_4^{2-} . Give the formula of chromium(III) sulfate.

..... [1]

(iii) Write the ionic half-equation for the reaction at the negative electrode (cathode).

..... [2]

(iv) A colourless gas, which relights a glowing splint, is formed at the positive electrode (anode).

State the name of this gas.

..... [1]

- (v) During electroplating, it is necessary to add more chromium(III) sulfate but during copper plating using a copper anode, it is not necessary to add more copper(II) sulfate.

Explain this difference.

.....

.....

..... [2]

[Total: 12]

- 5 Iron is extracted from its ore, hematite, in the blast furnace.

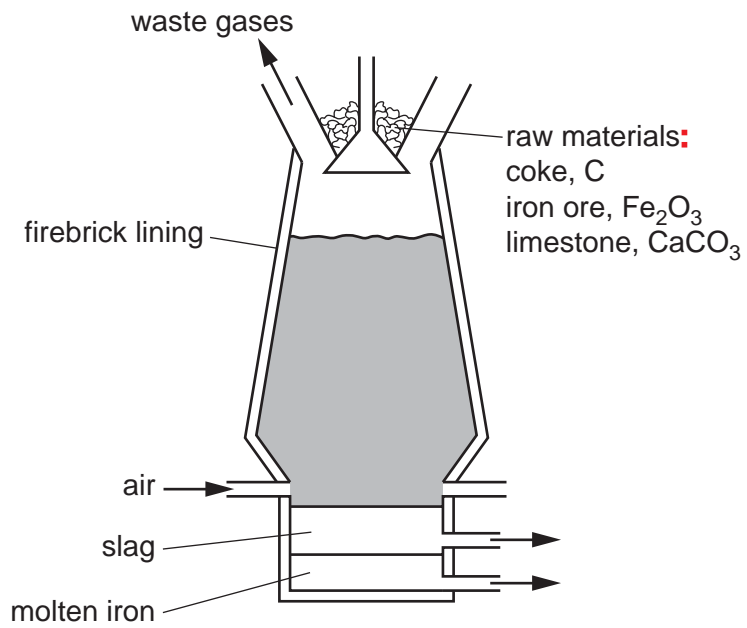

Describe the reactions involved in this extraction.

Include one equation for a redox reaction and one for an acid/base reaction.

.....

.....

.....

.....

.....

.....

.....

.....

.....

.....

.....

.....

.....

[5]

[Total: 5]

BLANK PAGE

6 Soluble salts can be made using a base and an acid.

(a) Complete this method of preparing dry crystals of the soluble salt cobalt(II) chloride-6-water from the insoluble base cobalt(II) carbonate.

step 1

Add an excess of cobalt(II) carbonate to hot dilute hydrochloric acid.

step 2

.....
.....

step 3

.....
.....

step 4

.....
.....

[4]

- (b) (i) 5.95 g of cobalt(II) carbonate were added to 40 cm³ of hydrochloric acid, concentration 2.0 mol/dm³.

Calculate the maximum yield of cobalt(II) chloride-6-water and show that the cobalt(II) carbonate was in excess.

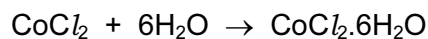

maximum yield:

number of moles of HCl used =

number of moles of CoCl₂ formed =

number of moles of CoCl₂·6H₂O formed =

mass of one mole of CoCl₂·6H₂O = 238 g

maximum yield of CoCl₂·6H₂O = g

to show that cobalt(II) carbonate is in excess:

number of moles of HCl used = (use your value from above)

mass of one mole of CoCO₃ = 119 g

number of moles of CoCO₃ in 5.95 g of cobalt(II) carbonate = [5]

- (ii) Explain how these calculations show that cobalt(II) carbonate is in excess.

..... [1]

[Total: 10]

- 7 Iodine reacts with chlorine to form dark brown iodine monochloride.

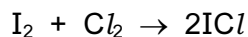

This reacts with more chlorine to give yellow iodine trichloride.
An equilibrium forms between these iodine chlorides.

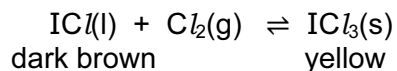

- (a) What do you understand by the term *equilibrium*?

.....

 [2]

- (b) When the equilibrium mixture is heated, it becomes a darker brown colour.
Suggest if the reverse reaction is endothermic or exothermic. Give a reason for your choice.

.....

 [1]

- (c) The pressure on the equilibrium mixture is decreased.

- (i) How would this affect the position of equilibrium? Give a reason for your choice.

It would move to the

reason

..... [1]

- (ii) Describe what you would observe.

.....
 [1]

- (d) Calculate the overall energy change for the reaction between iodine and chlorine using the bond energy values shown.

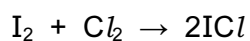

Bond	Energy / kJ per mol
I-I	151
Cl-Cl	242
I-Cl	208

Show your working.

[3]

- (e) Draw a labelled energy level diagram for the reaction between iodine and chlorine using the information in (d).

[2]

[Total: 10]

8 The alcohols form an homologous series.

(a) Give **three** characteristics of an homologous series.

.....
.....
.....
..... [3]

(b) The following two alcohols are members of an homologous series and they are isomers.

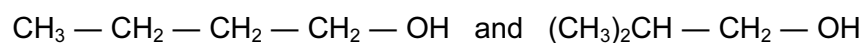

(i) Explain why they are isomers.

.....
.....
..... [2]

(ii) Deduce the structural formula of another alcohol which is also an isomer of these alcohols.

[1]

(c) Copper(II) oxide can oxidise butanol to liquid X, whose pH is 4.

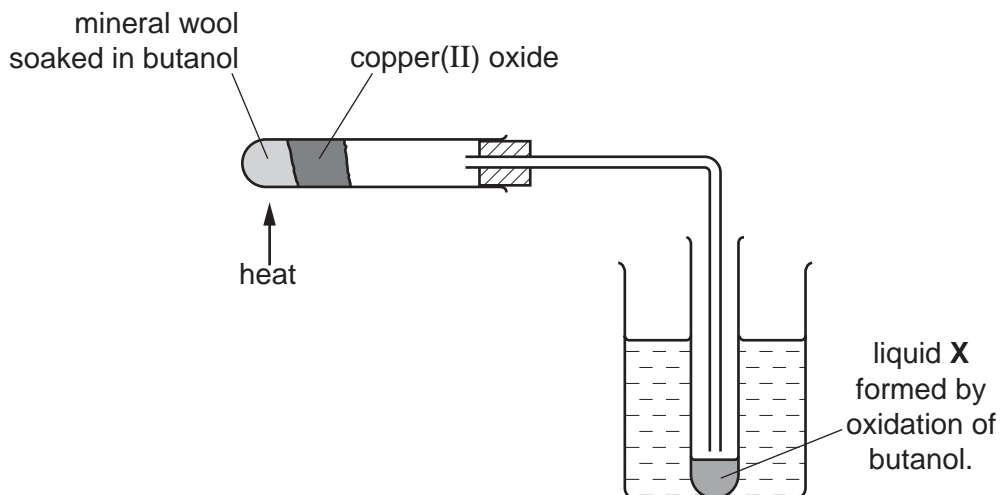

(i) Give the name of another reagent which can oxidise butanol.

..... [1]

(ii) Which homologous series does liquid X belong to?

..... [1]

(iii) State the formula of liquid X.

..... [1]

(d) The alcohol ethanol can be made by fermentation. Yeast is added to aqueous glucose.

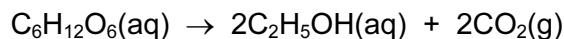

Carbon dioxide is given off and the mixture becomes warm, as the reaction is exothermic. The graph shows how the rate of reaction varies over several days.

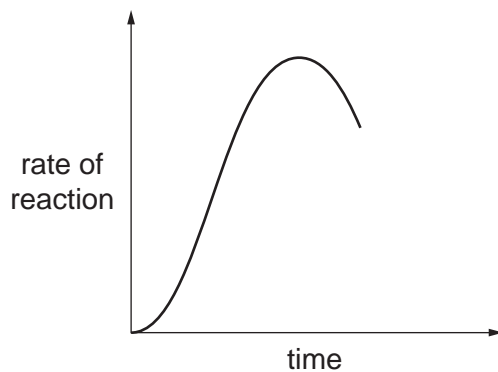

(i) Suggest a method of measuring the rate of this reaction.

.....
 [2]

(ii) Why does the rate initially increase?

.....
 [1]

(iii) Suggest **two** reasons why the rate eventually decreases.

.....
 [2]

[Total: 14]

9 There are two types of polymerisation, addition and condensation.

(a) Explain the difference between these two types of polymerisation.

.....
.....
..... [2]

(b) Some plastics, formed by polymerisation, are non-biodegradable.

Describe **two** pollution problems that are caused by non-biodegradable plastics.

.....
.....
.....
..... [2]

- (c) The polymer known as PVA is used in paints and adhesives. Its structural formula is shown below.

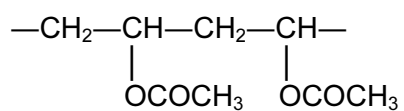

Deduce the structural formula of its monomer.

[1]

- (d) A condensation polymer can be made from the following monomers.

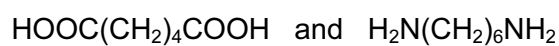

Draw the structural formula of this polymer.

[3]

[Total: 8]

Group																																																																				
I	II	III	IV	V	VI	VII	VIII																																																													
3 Li lithium 7	4 Be beryllium 9	11 Na sodium 23	12 Mg magnesium 24	13 Al aluminium 27	14 Si silicon 28	15 P phosphorus 31	16 S sulphur 32	17 Cl chlorine 35.5	18 Ar argon 40	2 He helium 4																																																										
<div style="display: flex; justify-content: space-between;"> <div style="border: 1px solid black; padding: 5px;"> 1 H hydrogen 1 </div> <div style="border: 1px solid black; padding: 5px;"> atomic number atomic symbol name relative atomic mass </div> </div>																																																																				
19 K potassium 39	20 Ca calcium 40	21 Sc scandium 45	22 Ti titanium 48	23 V vanadium 51	24 Cr chromium 52	25 Mn manganese 55	26 Fe iron 56	27 Co cobalt 59	28 Ni nickel 59	29 Cu copper 64	30 Zn zinc 65	31 Ga gallium 70	32 Ge germanium 73	33 As arsenic 75	34 Se selenium 79	35 Br bromine 80	36 Kr krypton 84	37 Rb rubidium 85	38 Sr strontium 88	39 Y yttrium 89	40 Zr zirconium 91	41 Nb niobium 93	42 Mo molybdenum 96	43 Tc technetium -	44 Ru ruthenium 101	45 Rh rhodium 103	46 Pd palladium 106	47 Ag silver 108	48 Cd cadmium 112	49 In indium 115	50 Sn tin 117	51 Sb antimony 122	52 Te tellurium 128	53 I iodine 127	54 Xe xenon 131	55 Cs caesium 133	56 Ba barium 137	57-71 lanthanoids	72 Hf hafnium 178	73 Ta tantalum 181	74 W tungsten 184	75 Re rhenium 186	76 Os osmium 190	77 Ir iridium 192	78 Pt platinum 195	79 Au gold 197	80 Hg mercury 201	81 Tl thallium 204	82 Pb lead 207	83 Bi bismuth 209	84 Po polonium -	85 At astatine -	86 Rn radon -	87 Fr francium -	88 Ra radium -	89-103 actinoids	104 Rf rutherfordium -	105 Db dubnium -	106 Sg seaborgium -	107 Bh bohrium -	108 Hs hassium -	109 Mt meitnerium -	110 Ds darmstadtium -	111 Rg roentgenium -	112 Cr copernicium -	114 Fl flerovium -	116 Lv livermorium -	118 Og oganesson -
57 La lanthanum 139	58 Ce cerium 140	59 Pr praseodymium 141	60 Nd neodymium 144	61 Pm promethium -	62 Sm samarium 150	63 Eu europium 152	64 Gd gadolinium 157	65 Tb terbium 159	66 Dy dysprosium 163	67 Ho holmium 165	68 Er erbium 167	69 Tm thulium 169	70 Yb ytterbium 173	71 Lu lutetium 175	89 Ac actinium -	90 Th thorium 232	91 Pa protactinium 231	92 U uranium 238	93 Np neptunium -	94 Pu plutonium -	95 Am americium -	96 Cm curium -	97 Bk berkelium -	98 Cf californium -	99 Es einsteinium -	100 Fm fermium -	101 Md mendelevium -	102 No nobelium -	103 Lr lawrencium -																																							

The volume of one mole of any gas is 24 dm³ at room temperature and pressure (r.t.p.)

Permission to reproduce items where third-party owned material protected by copyright is included has been sought and cleared where possible. Every reasonable effort has been made by the publisher (UCLES) to trace copyright holders, but if any items requiring clearance have unwittingly been included, the publisher will be pleased to make amends at the earliest possible opportunity.

Cambridge International Examinations is part of the Cambridge Assessment Group. Cambridge Assessment is the brand name of University of Cambridge Local Examinations Syndicate (UCLES), which is itself a department of the University of Cambridge.