



UNIVERSITY OF CAMBRIDGE INTERNATIONAL EXAMINATIONS
International General Certificate of Secondary Education

CANDIDATE
NAME

CENTRE
NUMBER

--	--	--	--	--

CANDIDATE
NUMBER

--	--	--	--



* 7 0 6 1 4 1 9 5 5 6 *

CHEMISTRY

0620/32

Paper 3 (Extended)

October/November 2010

1 hour 15 minutes

Candidates answer on the Question Paper.

No Additional Materials are required.

READ THESE INSTRUCTIONS FIRST

Write your Centre number, candidate number and name on all the work you hand in.

Write in dark blue or black pen.

You may use a pencil for any diagrams, graphs or rough working.

Do not use staples, paper clips, highlighters, glue or correction fluid.

DO NOT WRITE IN ANY BARCODES.

Answer **all** questions.

A copy of the Periodic Table is printed on page 16.

At the end of the examination, fasten all your work securely together.

The number of marks is given in brackets [] at the end of each question or part question.

For Examiner's Use	
1	
2	
3	
4	
5	
6	
7	
Total	

This document consists of **14** printed pages and **2** blank pages.



1 The following table gives information about six substances.

substance	melting point /°C	boiling point /°C	electrical conductivity as a solid	electrical conductivity as a liquid
A	839	1484	good	good
B	-210	-196	poor	poor
C	776	1497	poor	good
D	-117	78	poor	poor
E	1607	2227	poor	poor
F	-5	102	poor	good

(a) Which substance could have a macromolecular structure, similar to that of silicon(IV) oxide?

..... [1]

(b) Which substances are solids at room temperature?

..... [1]

(c) Which substance could be a metal?

..... [1]

(d) Which substance could be aqueous sodium chloride?

..... [1]

(e) Which substance is an ionic compound?

..... [1]

(f) Which substances are liquids at room temperature?

..... [1]

[Total: 6]

2 An ore of the important metal zinc is zinc blende, ZnS. This is changed into zinc oxide which is reduced to the impure metal by carbon reduction.

(a) (i) How is zinc oxide obtained from zinc sulfide?

.....
..... [2]

(ii) Write a balanced equation for the reduction of zinc oxide by carbon.

..... [1]

(iii) The major impurity in the zinc is cadmium. The boiling point of zinc is 907 °C and that of cadmium is 767 °C.

Name a technique which could be used to separate these two metals.

..... [2]

(b) In common with most metals, zinc is a good conductor of electricity. It is used as an electrode in cells.

(i) Give **two** other uses of zinc.

.....
..... [2]

(ii) Describe the metallic bonding in zinc and then explain why it is a good conductor of electricity.

.....
.....
.....
..... [4]

[Total: 11]

3 The decomposition of hydrogen peroxide is catalysed by manganese(IV) oxide.



To 50 cm³ of aqueous hydrogen peroxide, 0.50 g of manganese(IV) oxide was added. The volume of oxygen formed was measured every 20 seconds. The average reaction rate was calculated for each 20 second interval.

time/s	0	20	40	60	80	100
volume of oxygen/cm ³	0	48	70	82	88	88
average reaction rate in cm ³ /s	2.4	1.1	0.3	0.0	0.0

(a) Explain how the average reaction rate, 2.4 cm³/s, was calculated for the first 20 seconds.

.....
 [2]

(b) Complete the table. [1]

(c) Explain why the average reaction rate decreases with time.

.....
 [2]

(d) The experiment was repeated but 1.0 g of manganese(IV) oxide was added. What effect, if any, would this have on the reaction rate and on the final volume of oxygen? Give a reason for each answer.

effect on rate [1]

reason

..... [2]

effect on final volume of oxygen [1]

reason

..... [2]

[Total: 11]

4 Chromium is a transition element.

(a) (i) Predict **two** differences in the physical properties of chromium and sodium.

.....
..... [2]

(ii) Predict **two** differences in the chemical properties of chromium and sodium.

.....
..... [2]

(b) Chromium is used to electroplate steel objects. The diagram shows how this could be done.

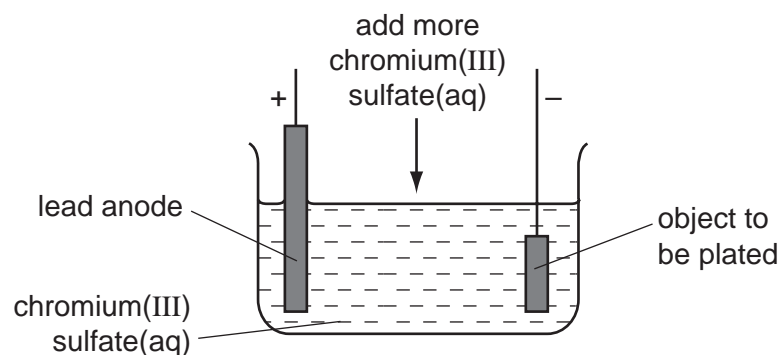

(i) Give **two** reasons why steel objects are plated with chromium.

.....
..... [2]

(ii) The formula of the chromium(III) ion is Cr^{3+} and of the sulfate ion is SO_4^{2-} . Give the formula of chromium(III) sulfate.

..... [1]

(iii) Write the equation for the reaction at the negative electrode (cathode).

..... [2]

(iv) A colourless gas, which relights a glowing splint, is formed at the positive electrode (anode). Name this gas.

..... [1]

- (v) During electrolysis, it is necessary to add more chromium(III) sulfate but during copper-plating using a copper anode, it is not necessary to add more copper(II) sulfate. Explain.

.....
.....
..... [2]

[Total: 12]

- 5 In the absence of oxygen, certain bacteria decompose carbohydrates to biogas. This is a mixture of gases mainly methane and carbon dioxide. Biogas is becoming an increasingly important fuel around the world.

A diagram of a simple biogas generator is given below. Typically, it contains biomass - animal manure, plant material etc.

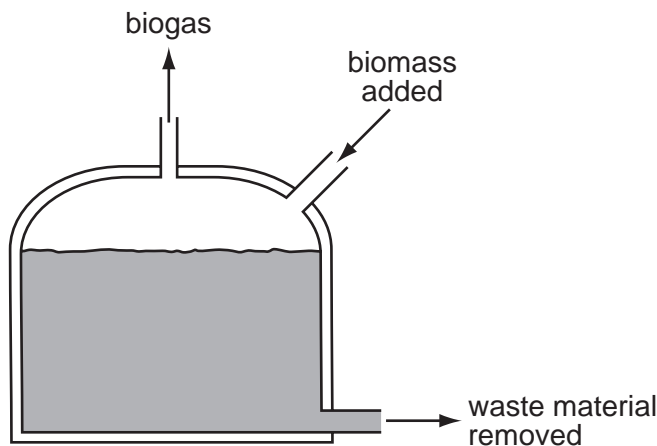

- (a) (i) What is meant by the term *carbohydrate*?

.....
 [2]

- (ii) The reaction in the generator is an example of anaerobic respiration. Anaerobic means in the absence of oxygen. What does *respiration* mean?

.....
 [2]

- (iii) The generator must produce some carbon dioxide. Why is it impossible for it to produce only a hydrocarbon such as methane?

..... [1]

- (iv) Suggest a use for the nitrogen-rich solid removed from the generator.

..... [1]

- (b) (i)** In an experiment, a 60 cm³ sample of biogas required 80 cm³ of oxygen for the complete combustion of the methane in the sample.
Calculate the percentage of methane in the sample of biogas. Assume that biogas contains only methane and carbon dioxide.

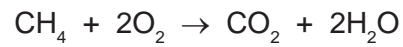

.....
.....
..... [2]

- (ii)** Carbon dioxide is acidic and methane is neutral.
Suggest another way of measuring the volume of methane in the sample.

.....
..... [2]

[Total: 10]

6 The alcohols form an homologous series.

(a) Give **three** characteristics of an homologous series.

.....
.....
.....
..... [3]

(b) The following two alcohols are members of the series and they are isomers.



(i) Explain why they are isomers.

.....
.....
..... [2]

(ii) Give the structural formula of another alcohol which is also an isomer of these alcohols.

[1]

(c) Copper(II) oxide can oxidise butan-1-ol to liquid X whose pH is 4.

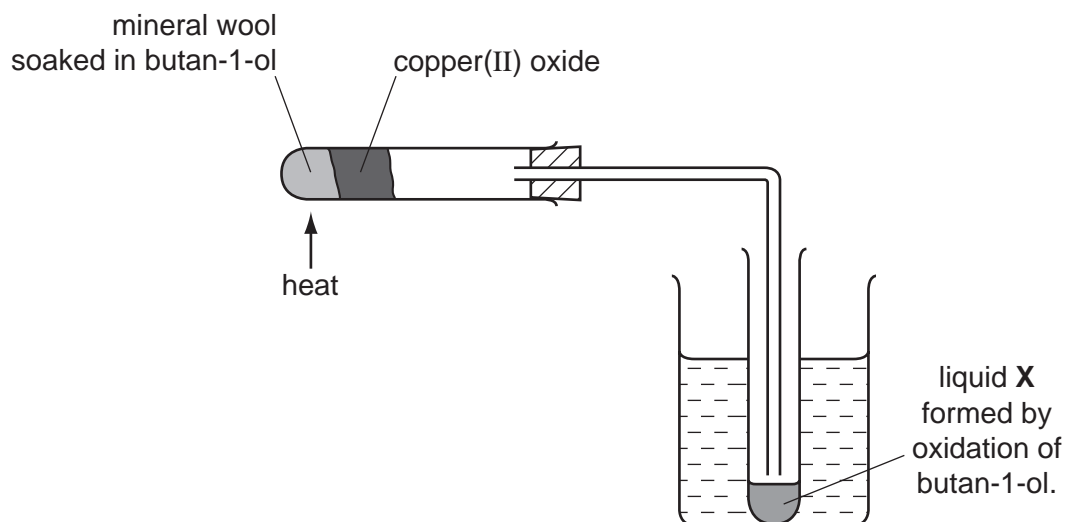

(i) Name another reagent which can oxidise butan-1-ol.

..... [1]

(ii) What type of compound is liquid X and what is its formula?

type of compound [1]

formula of liquid X

[1]

(d) The alcohol ethanol can be made by fermentation. Yeast is added to aqueous glucose.

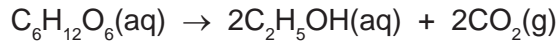

Carbon dioxide is given off and the mixture becomes warm as the reaction is exothermic. The graph shows how the rate of reaction varies over several days.

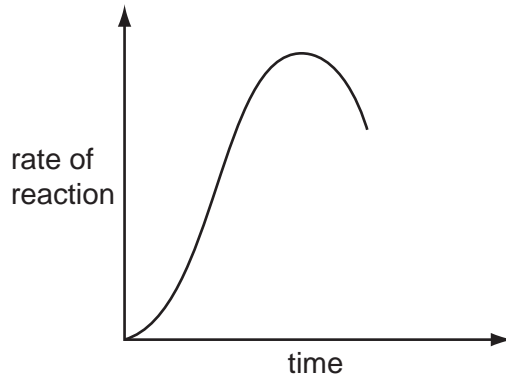

(i) Suggest a method of measuring the rate of this reaction.

.....
 [2]

(ii) Why does the rate increase initially?

.....
 [1]

(iii) Suggest **two** reasons why the rate eventually decreases.

.....
 [2]

(iv) Why is fermentation carried out in the absence of air?

.....
 [1]

[Total: 15]

7 The major use of sulfur dioxide is to manufacture sulfuric acid.

(a) (i) Another use of sulfur dioxide is as the food additive E220.
How does it preserve food?

.....
..... [1]

(ii) Why is sulfur dioxide used in the manufacture of wood pulp?

..... [1]

(iii) How is sulfur dioxide manufactured?

..... [1]

(b) Complete the following description of the manufacture of sulfuric acid.

Sulfur dioxide reacts with to form sulfur trioxide.

The above reaction is catalysed by

The optimum temperature for this reaction is °C.

Sulfur trioxide needs to react with to form sulfuric acid. [4]

(c) (i) Define the term *acid*.

..... [1]

(ii) Sulfuric acid is a strong acid. Ethanedioic acid is a weak acid.

Given solutions of both acids, how could you show that sulfuric acid is a strong acid and ethanedioic acid is a weak acid?

method
..... [1]

result for each acid
..... [1]

- (d) 20.0 cm³ of sulfuric acid, concentration 0.30 mol / dm³, was added to 40 cm³ of sodium hydroxide, concentration 0.20 mol/dm³.

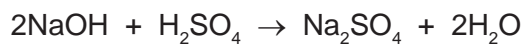

- (i) How many moles of H₂SO₄ were added? [1]
- (ii) How many moles of NaOH were used? [1]
- (iii) Which reagent is in excess? Give a reason for your choice.
- reagent in excess [1]
- reason [1]
- [1]
- (iv) Is the pH of the final mixture less than 7, equal to 7 or more than 7?
- [1]

[Total: 15]

