



UNIVERSITY OF CAMBRIDGE INTERNATIONAL EXAMINATIONS
International General Certificate of Secondary Education

CANDIDATE
NAME

CENTRE
NUMBER

--	--	--	--	--

CANDIDATE
NUMBER

--	--	--	--



CHEMISTRY

0620/32

Paper 3 (Extended)

May/June 2010

1 hour 15 minutes

Candidates answer on the Question Paper.

No Additional Materials are required.

READ THESE INSTRUCTIONS FIRST

Write your Centre number, candidate number and name on all the work you hand in.

Write in dark blue or black pen.

You may use a pencil for any diagrams, graphs or rough working.

Do not use staples, paper clips, highlighters, glue or correction fluid.

DO NOT WRITE IN ANY BARCODES.

Answer **all** questions.

A copy of the Periodic Table is printed on page 16.

At the end of the examination, fasten all your work securely together.

The number of marks is given in brackets [] at the end of each question or part question.

For Examiner's Use	
1	
2	
3	
4	
5	
6	
7	
8	
Total	

This document consists of **13** printed pages and **3** blank pages.



1 For each of the following unfamiliar elements predict one physical and one chemical property.

(a) caesium (Cs)

physical property

chemical property

..... [2]

(b) vanadium (V)

physical property

chemical property

..... [2]

(c) fluorine (F)

physical property

chemical property

..... [2]

[Total: 6]

2 The hydrolysis of complex carbohydrates to simple sugars is catalysed by enzymes called carbohydrases and also by dilute acids.

(a) (i) They are both catalysts. How do enzymes differ from catalysts such as dilute acids?

..... [1]

(ii) Explain why ethanol, C_2H_6O , is not a carbohydrate but glucose, $C_6H_{12}O_6$, is a carbohydrate.

.....

..... [2]

(b) Draw the structure of a complex carbohydrate, such as starch. The formula of a simple sugar can be represented by $HO-\square-OH$.

[3]

(c) Iodine reacts with starch to form a deep blue colour.

(i) In the experiment illustrated below, samples are removed at intervals and tested with iodine in potassium iodide solution.

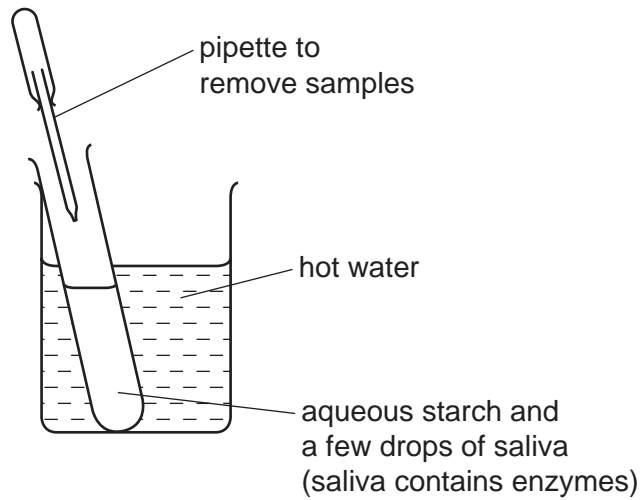

Typical results of this experiment are shown in the table.

time / min	colour of sample tested with iodine in potassium iodide solution
0	deep blue
10	pale blue
30	colourless

Explain these results.

.....

 [3]

(ii) If the experiment was repeated at a higher temperature, 60 °C, all the samples stayed blue. Suggest an explanation.

..... [1]

[Total: 10]

3 The following are examples of redox reactions.

(a) Bromine water was added to aqueous sodium sulfide.

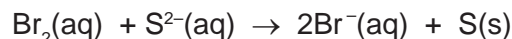

(i) Describe what you would observe when this reaction occurs.

.....
 [2]

(ii) Write a symbol equation for this reaction.

..... [1]

(iii) Explain, in terms of electron transfer, why bromine is the oxidant (oxidising agent) in this reaction.

.....
 [2]

(b) Iron and steel in the presence of water and oxygen form rust.

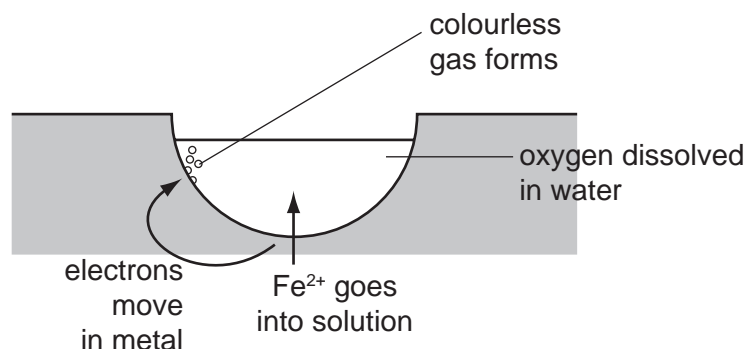

The reactions involved are:

reaction 1



The electrons move through the iron on to the surface where a colourless gas forms.

reaction 2

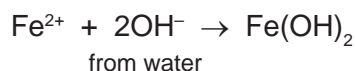

reaction 3



The water evaporates to leave rust.

- (i) What type of reaction is **reaction 1**? [1]
- (ii) Deduce the name of the colourless gas mentioned in **reaction 1**.
..... [1]
- (iii) What is the name of the iron compound formed in **reaction 2**?
..... [1]
- (iv) Balance the equation for **reaction 3**.
..... $\text{Fe}(\text{OH})_2 + \text{O}_2 + \dots\dots\dots\text{H}_2\text{O} \rightarrow \dots\dots\dots\text{Fe}(\text{OH})_3$ [1]
- (v) Explain why the change $\text{Fe}(\text{OH})_2$ to $\text{Fe}(\text{OH})_3$ is oxidation.
.....
..... [1]
- (vi) Explain why iron in electrical contact with a piece of zinc does not rust.
.....
.....
..... [3]

[Total: 13]

- 4 But-1-ene is a typical alkene. It has the structural formula shown below.

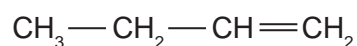

The structural formula of cyclobutane is given below.

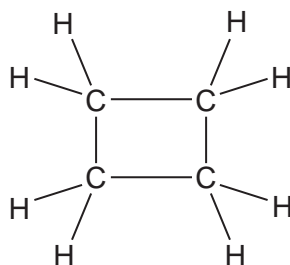

- (a) These two hydrocarbons are isomers.

- (i) Define the term *isomer*.

.....
..... [2]

(ii) Draw the structural formula of another isomer of but-1-ene.

[1]

(iii) Describe a test which would distinguish between but-1-ene and cyclobutane.

reagent

result with but-1-ene

.....

result with cyclobutane

..... [3]

(b) Describe how alkenes, such as but-1-ene, can be made from alkanes.

.....

..... [2]

(c) Name the product formed when but-1-ene reacts with:

bromine, [1]

hydrogen, [1]

steam. [1]

[Total: 11]

- 5 Fuel cells are used in spacecraft to produce electrical energy.

For
Examiner's
Use

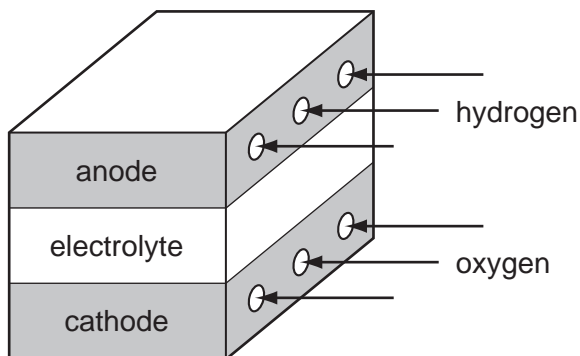

- (a) How is oxygen obtained from liquid air?

.....
..... [2]

- (b) Hydrogen and oxygen react to form water.

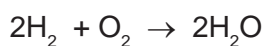

- (i) Give an example of bond breaking in the above reaction.

..... [1]

- (ii) Give an example of bond forming in the above reaction.

..... [1]

- (iii) Is the change given in (i) exothermic or endothermic?

..... [1]

- (c) (i) Give **two** reasons why hydrogen may be considered to be the ideal fuel for the future.

.....
.....
..... [2]

- (ii) Suggest a reason why hydrogen is not widely used at the moment.

.....
..... [1]

[Total: 8]

6 Thallium is a metal in Group III. It has oxidation states of +1 and +3.

(a) Give the formula for the following thallium compounds.

(i) thallium(I) sulfide [1]

(ii) thallium(III) chloride [1]

(b) Thallium(I) chloride is insoluble in water. Complete the description of the preparation of a pure sample of this salt.

Step 1

Mix a solution of sodium chloride with thallium(I) sulfate solution. A white precipitate forms.

Step 2

..... [1]

Step 3

..... [1]

Step 4

..... [1]

(c) When thallium(I) chloride is exposed to light, a photochemical reaction occurs. It changes from a white solid to a violet solid.

(i) Name another metal halide which changes colour when exposed to light. Give the major use of this metal halide.

name

use [2]

(ii) A piece of paper coated with thallium(I) chloride is exposed to a bright light.

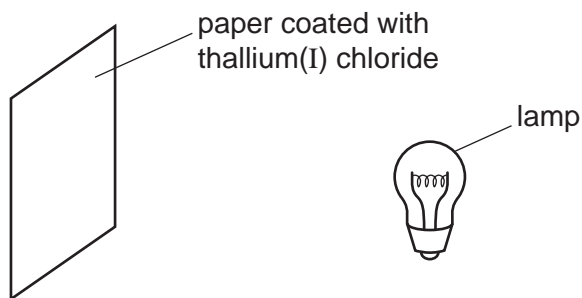

Suggest **two** ways of increasing the time it takes for the violet colour to appear.

.....

 [2]

(d) Thallium(I) hydroxide is an alkali. It has similar properties to sodium hydroxide.

(i) Complete the following word equation.

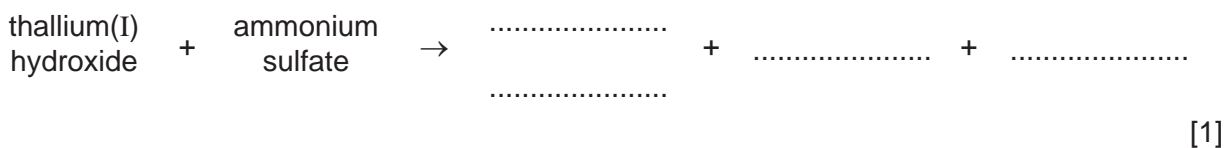

(ii) Complete the equation.

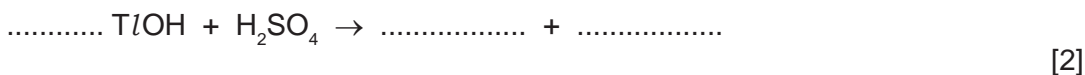

(iii) Aqueous thallium(I) hydroxide was added to aqueous iron(II) sulfate. Describe what you would see and complete the ionic equation for the reaction.

observation [1]



[Total: 14]

7 Aluminium was first isolated in 1827 using sodium.

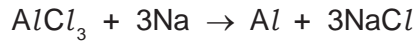

Aluminium, obtained by this method, was more expensive than gold.

(a) Suggest an explanation why aluminium was so expensive.

.....
..... [1]

(b) The modern method for extracting aluminium is the electrolysis of a molten electrolyte, aluminium oxide dissolved in cryolite. The aluminium oxide decomposes.

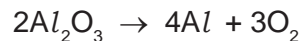

Both electrodes are made of carbon.

(i) Give **two** reasons why the oxide is dissolved in cryolite.

.....
.....
..... [2]

(ii) Complete the ionic equation for the reaction at the anode.



(iii) Why do the carbon anodes need to be replaced frequently?

.....
..... [1]

(c) The electrolysis of a molten electrolyte is one method of extracting a metal from its ore. Other methods are the electrolysis of an aqueous solution and the reduction of the oxide by carbon. Explain why these last two methods cannot be used to extract aluminium.

electrolysis of an aqueous solution

.....

using carbon

..... [2]

[Total: 8]

8 Nitrogen dioxide is a brown gas. It can be made by heating certain metal nitrates.



(a) (i) Name another metal whose nitrate decomposes to give the metal oxide, nitrogen dioxide and oxygen.

..... [1]

(ii) Complete the word equation for a metal whose nitrate does not give nitrogen dioxide on decomposition.

metal nitrate → + oxygen [1]

(b) At most temperatures, samples of nitrogen dioxide are equilibrium mixtures.

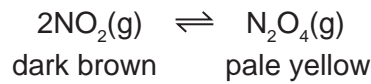

(i) At 25 °C, the mixture contains 20 % of nitrogen dioxide. At 100 °C this has risen to 90 %. Is the forward reaction exothermic or endothermic? Give a reason for your choice.

.....

 [2]

(ii) Explain why the colour of the equilibrium mixture becomes lighter when the pressure on the mixture is increased.

.....

 [2]

- (c) A 5.00g sample of impure lead(II) nitrate was heated. The volume of oxygen formed was 0.16 dm³ measured at r.t.p. The impurities did not decompose. Calculate the percentage of lead(II) nitrate in the sample.



Number of moles of O₂ formed =

Number of moles of Pb(NO₃)₂ in the sample =

Mass of one mole of Pb(NO₃)₂ = 331 g

Mass of lead(II) nitrate in the sample = g

Percentage of lead(II) nitrate in sample = [4]

[Total: 10]

DATA SHEET
The Periodic Table of the Elements

		Group																																																																		
I	II	III	IV	V	VI	VII	0																																																													
7 Li Lithium 3	9 Be Beryllium 4	1 H Hydrogen 1	11 B Boron 5	12 C Carbon 6	13 Al Aluminium 13	14 N Nitrogen 7	15 O Oxygen 8	16 F Fluorine 9	17 Ne Neon 10	18 Ar Argon 18	19 K Potassium 19	20 Ca Calcium 20	21 Sc Scandium 21	22 Ti Titanium 22	23 V Vanadium 23	24 Cr Chromium 24	25 Mn Manganese 25	26 Fe Iron 26	27 Co Cobalt 27	28 Ni Nickel 28	29 Cu Copper 29	30 Zn Zinc 30	31 Ga Gallium 31	32 Ge Germanium 32	33 As Arsenic 33	34 Se Selenium 34	35 Br Bromine 35	36 Kr Krypton 36	37 Rb Rubidium 37	38 Sr Strontium 38	39 Y Yttrium 39	40 Zr Zirconium 40	41 Nb Niobium 41	42 Mo Molybdenum 42	43 Tc Technetium 43	44 Ru Ruthenium 44	45 Rh Rhodium 45	46 Pd Palladium 46	47 Ag Silver 47	48 Cd Cadmium 48	49 In Indium 49	50 Sn Tin 50	51 Sb Antimony 51	52 Te Tellurium 52	53 I Iodine 53	54 Xe Xenon 54	55 Cs Caesium 55	56 Ba Barium 56	57 La Lanthanum 57	72 Hf Hafnium 72	73 Ta Tantalum 73	74 W Tungsten 74	75 Re Rhenium 75	76 Os Osmium 76	77 Ir Iridium 77	78 Pt Platinum 78	79 Au Gold 79	80 Hg Mercury 80	81 Tl Thallium 81	82 Pb Lead 82	83 Bi Bismuth 83	84 Po Polonium 84	85 At Astatine 85	86 Rn Radon 86	87 Fr Francium 87	88 Ra Radium 88	89 Ac Actinium 89	†
133 Cs Caesium 55	137 Ba Barium 56	139 La Lanthanum 57	140 Ce Cerium 58	141 Pr Praseodymium 59	144 Nd Neodymium 60	150 Sm Samarium 62	152 Eu Europium 63	157 Gd Gadolinium 64	162 Dy Dysprosium 66	165 Ho Holmium 67	167 Er Erbium 68	169 Tm Thulium 69	175 Lu Lutetium 71	140 Ce Cerium 58	141 Pr Praseodymium 59	144 Nd Neodymium 60	150 Sm Samarium 62	152 Eu Europium 63	157 Gd Gadolinium 64	162 Dy Dysprosium 66	165 Ho Holmium 67	167 Er Erbium 68	169 Tm Thulium 69	175 Lu Lutetium 71	232 Th Thorium 90	238 U Uranium 92	238 Pa Protactinium 91	91 Th Thorium 90	92 U Uranium 92	93 Np Neptunium 93	94 Pu Plutonium 94	95 Am Americium 95	96 Cm Curium 96	97 Bk Berkelium 97	98 Cf Californium 98	99 Es Einsteinium 99	100 Fm Fermium 100	101 Md Mendelevium 101	102 No Nobelium 102	103 Lr Lawrencium 103																												

*58-71 Lanthanoid series
†90-103 Actinoid series

Key

a	X
b	

a = relative atomic mass
 X = atomic symbol
 b = proton (atomic) number

The volume of one mole of any gas is 24 dm³ at room temperature and pressure (r.t.p.).

Permission to reproduce items where third-party owned material protected by copyright is included has been sought and cleared where possible. Every reasonable effort has been made by the publisher (UCLES) to trace copyright holders, but if any items requiring clearance have unwittingly been included the publisher will be pleased to make amends at the earliest possible opportunity.