

UNIVERSITY OF CAMBRIDGE INTERNATIONAL EXAMINATIONS
General Certificate of Education
Advanced Subsidiary Level and Advanced Level

MATHEMATICS

9709/01

Paper 1 Pure Mathematics 1 (P1)

October/November 2005

1 hour 45 minutes

Additional materials: Answer Booklet/Paper
Graph paper
List of Formulae (MF9)

READ THESE INSTRUCTIONS FIRST

If you have been given an Answer Booklet, follow the instructions on the front cover of the Booklet.
Write your Centre number, candidate number and name on all the work you hand in.
Write in dark blue or black pen on both sides of the paper.
You may use a soft pencil for any diagrams or graphs.
Do not use staples, paper clips, highlighters, glue or correction fluid.

Answer **all** the questions.
Give non-exact numerical answers correct to 3 significant figures, or 1 decimal place in the case of angles in degrees, unless a different level of accuracy is specified in the question.
At the end of the examination, fasten all your work securely together.

The number of marks is given in brackets [] at the end of each question or part question.
The total number of marks for this paper is 75.
Questions carrying smaller numbers of marks are printed earlier in the paper, and questions carrying larger numbers of marks later in the paper.
The use of an electronic calculator is expected, where appropriate.
You are reminded of the need for clear presentation in your answers.

This document consists of 4 printed pages.



1 Solve the equation $3 \sin^2 \theta - 2 \cos \theta - 3 = 0$, for $0^\circ \leq \theta \leq 180^\circ$. [4]

2

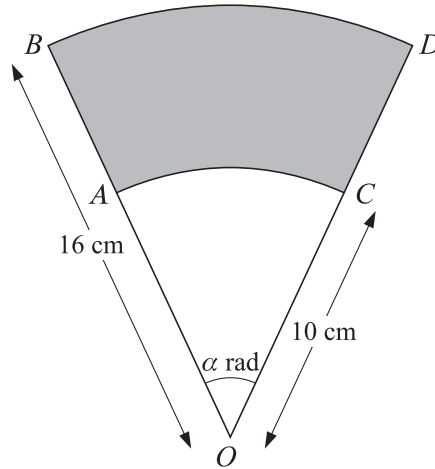

In the diagram, OAB and OCD are radii of a circle, centre O and radius 16 cm. Angle $AOC = \alpha$ radians. AC and BD are arcs of circles, centre O and radii 10 cm and 16 cm respectively.

(i) In the case where $\alpha = 0.8$, find the area of the shaded region. [2]

(ii) Find the value of α for which the perimeter of the shaded region is 28.9 cm. [3]

3

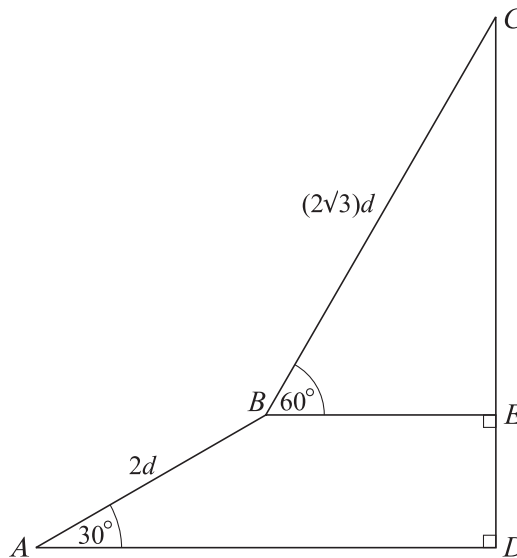

In the diagram, $ABED$ is a trapezium with right angles at E and D , and CED is a straight line. The lengths of AB and BC are $2d$ and $(2\sqrt{3})d$ respectively, and angles BAD and CBE are 30° and 60° respectively.

(i) Find the length of CD in terms of d . [2]

(ii) Show that angle $CAD = \tan^{-1}\left(\frac{2}{\sqrt{3}}\right)$. [3]

- 4 Relative to an origin O , the position vectors of points P and Q are given by

$$\overrightarrow{OP} = \begin{pmatrix} -2 \\ 3 \\ 1 \end{pmatrix} \quad \text{and} \quad \overrightarrow{OQ} = \begin{pmatrix} 2 \\ 1 \\ q \end{pmatrix},$$

where q is a constant.

- (i) In the case where $q = 3$, use a scalar product to show that $\cos POQ = \frac{1}{7}$. [3]

- (ii) Find the values of q for which the length of \overrightarrow{PQ} is 6 units. [4]

5

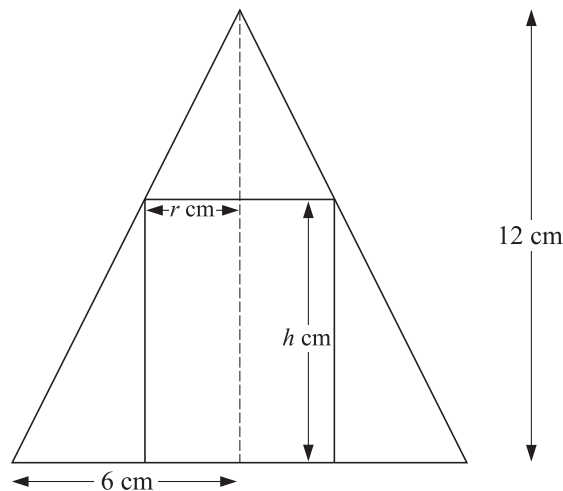

The diagram shows the cross-section of a hollow cone and a circular cylinder. The cone has radius 6 cm and height 12 cm, and the cylinder has radius r cm and height h cm. The cylinder just fits inside the cone with all of its upper edge touching the surface of the cone.

- (i) Express h in terms of r and hence show that the volume, $V \text{ cm}^3$, of the cylinder is given by

$$V = 12\pi r^2 - 2\pi r^3. \quad [3]$$

- (ii) Given that r varies, find the stationary value of V . [4]

- 6 A small trading company made a profit of \$250 000 in the year 2000. The company considered two different plans, plan A and plan B, for increasing its profits.

Under plan A, the annual profit would increase each year by 5% of its value in the preceding year. Find, for plan A,

- (i) the profit for the year 2008, [3]

- (ii) the total profit for the 10 years 2000 to 2009 inclusive. [2]

Under plan B, the annual profit would increase each year by a constant amount $\$D$.

- (iii) Find the value of D for which the total profit for the 10 years 2000 to 2009 inclusive would be the same for both plans. [3]

- 7 Three points have coordinates $A(2, 6)$, $B(8, 10)$ and $C(6, 0)$. The perpendicular bisector of AB meets the line BC at D . Find
- (i) the equation of the perpendicular bisector of AB in the form $ax + by = c$, [4]
 - (ii) the coordinates of D . [4]
- 8 A function f is defined by $f : x \mapsto (2x - 3)^3 - 8$, for $2 \leq x \leq 4$.
- (i) Find an expression, in terms of x , for $f'(x)$ and show that f is an increasing function. [4]
 - (ii) Find an expression, in terms of x , for $f^{-1}(x)$ and find the domain of f^{-1} . [4]
- 9 The equation of a curve is $xy = 12$ and the equation of a line l is $2x + y = k$, where k is a constant.
- (i) In the case where $k = 11$, find the coordinates of the points of intersection of l and the curve. [3]
 - (ii) Find the set of values of k for which l does not intersect the curve. [4]
 - (iii) In the case where $k = 10$, one of the points of intersection is $P(2, 6)$. Find the angle, in degrees correct to 1 decimal place, between l and the tangent to the curve at P . [4]
- 10 A curve is such that $\frac{dy}{dx} = \frac{16}{x^3}$, and $(1, 4)$ is a point on the curve.
- (i) Find the equation of the curve. [4]
 - (ii) A line with gradient $-\frac{1}{2}$ is a normal to the curve. Find the equation of this normal, giving your answer in the form $ax + by = c$. [4]
 - (iii) Find the area of the region enclosed by the curve, the x -axis and the lines $x = 1$ and $x = 2$. [4]