

Surname					Other Names				
Centre Number					Candidate Number				
Candidate Signature									

Leave blank

General Certificate of Education
 June 2002
 Advanced Level Examination



PHYSICS (SPECIFICATION B)
Unit 5

PHB5

Thursday 27 June 2002 Morning Session

In addition to this paper you will require:

- a calculator;
- a ruler.

For Examiner's Use			
Number	Mark	Number	Mark
1			
2			
3			
4			
5			
6			
7			
8			
9			
Total (Column 1)		→	
Total (Column 2)		→	
TOTAL			
Examiner's Initials			

Time allowed: 2 hours

Instructions

- Use blue or black ink or ball-point pen.
- Fill in the boxes at the top of this page.
- Answer **all** questions in the spaces provided.
- Do all rough work in this book. Cross through any work you do not want marked.
- All working must be shown, otherwise you may lose marks.
- *Formulae Sheet* are provided on pages 3 and 4. Detach this perforated page at the start of the examination.

Information

- The maximum mark for this paper is 100.
- Mark allocations are shown in brackets.
- Marks are awarded for units in addition to correct numerical answers, and for the use of appropriate numbers of significant figures.
- You are expected to use a calculator where appropriate.
- You will be assessed on your ability to use an appropriate form and style of writing, to organise relevant information clearly and coherently, and to use specialist vocabulary, where appropriate.
- The degree of legibility of your handwriting and the level of accuracy of your spelling, punctuation and grammar will also be taken into account.

Answer **all** questions in the spaces provided.

1

Total for this question: 8 marks

The Earth has an electric charge. The electric field strength outside the Earth varies in the same way as if this charge were concentrated at the centre of the Earth. The axes in **Figure 1** represent the electric field strength E and the distance from the centre of the Earth r . The electric field strength at **A** has been plotted.

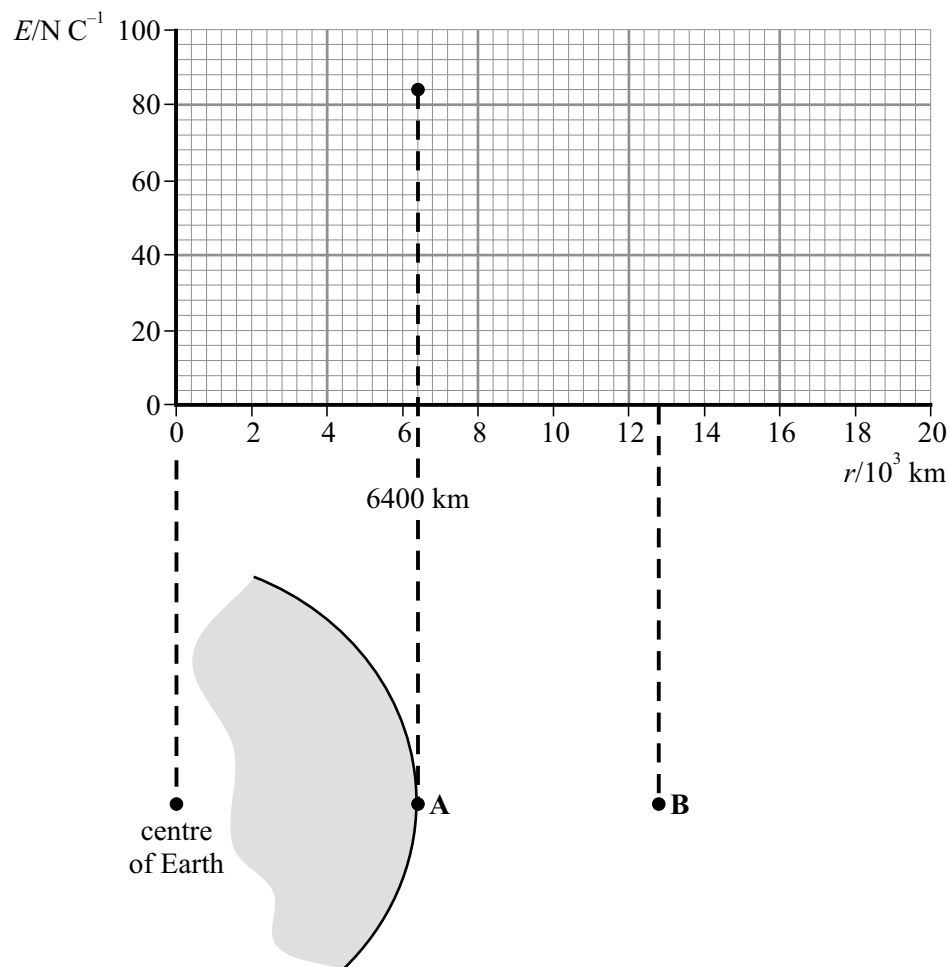

Figure 1

- (a) (i) Determine the electric field strength at **B** and then complete the graph to show how the electric field strength varies with distance from the centre of the Earth for distances greater than 6400 km.

(3 marks)

Detach this perforated page at the start of the examination.

Foundation Physics Mechanics Formulae

$$\text{moment of force} = Fd$$

$$v = u + at$$

$$s = ut + \frac{1}{2}at^2$$

$$v^2 = u^2 + 2as$$

$$s = \frac{1}{2}(u + v)t$$

$$\text{for a spring, } F = k\Delta l$$

$$\text{energy stored in a spring} = \frac{1}{2}F\Delta l = \frac{1}{2}k(\Delta l)^2$$

$$T = \frac{1}{f}$$

Foundation Physics Electricity Formulae

$$I = nAvq$$

$$\text{terminal p.d.} = E - Ir$$

$$\text{in series circuit, } R = R_1 + R_2 + R_3 + \dots$$

$$\text{in parallel circuit, } \frac{1}{R} = \frac{1}{R_1} + \frac{1}{R_2} + \frac{1}{R_3} + \dots$$

$$\text{output voltage across } R_1 = \left(\frac{R_1}{R_1 + R_2} \right) \times \text{input voltage}$$

Waves and Nuclear Physics Formulae

$$\text{fringe spacing} = \frac{\lambda D}{d}$$

$$\text{single slit diffraction minimum } \sin \theta = \frac{\lambda}{b}$$

$$\text{diffraction grating } n\lambda = d \sin \theta$$

$$\text{Doppler shift } \frac{\Delta f}{f} = \frac{v}{c} \text{ for } v \ll c$$

$$\text{Hubble law } v = Hd$$

$$\text{radioactive decay } A = \lambda N$$

Properties of Quarks

Type of quark	Charge	Baryon number
up u	$+\frac{2}{3}e$	$+\frac{1}{3}$
down d	$-\frac{1}{3}e$	$+\frac{1}{3}$
\bar{u}	$-\frac{2}{3}e$	$-\frac{1}{3}$
\bar{d}	$+\frac{1}{3}e$	$-\frac{1}{3}$

Lepton Numbers

Particle	Lepton number L		
	L_e	L_μ	L_τ
e^-	1		
e^+	-1		
ν_e	1		
$\bar{\nu}_e$	-1		
μ^-		1	
μ^+		-1	
ν_μ		1	
$\bar{\nu}_\mu$		-1	
τ^-			1
τ^+			-1
ν_τ			1
$\bar{\nu}_\tau$			-1

Geometrical and Trigonometrical Relationships

$$\text{circumference of circle} = 2\pi r$$

$$\text{area of a circle} = \pi r^2$$

$$\text{surface area of sphere} = 4\pi r^2$$

$$\text{volume of sphere} = \frac{4}{3}\pi r^3$$

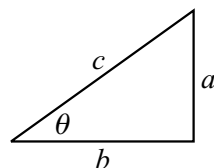

$$\sin \theta = \frac{a}{c}$$

$$\cos \theta = \frac{b}{c}$$

$$\tan \theta = \frac{a}{b}$$

$$c^2 = a^2 + b^2$$

Turn over ►

Detach this perforated page at the start of the examination.

Circular Motion and Oscillations

$$v = r\omega$$

$$a = -(2\pi f)^2 x$$

$$x = A \cos 2\pi ft$$

$$\text{maximum } a = (2\pi f)^2 A$$

$$\text{maximum } v = 2\pi f A$$

$$\text{for a mass-spring system, } T = 2\pi \sqrt{\frac{m}{k}}$$

$$\text{for a simple pendulum, } T = 2\pi \sqrt{\frac{l}{g}}$$

Fields and their Applications

$$\text{uniform electric field strength, } E = \frac{V}{d} = \frac{F}{Q}$$

$$\text{for a radial field, } E = \frac{kQ}{r^2}$$

$$k = \frac{1}{4\pi\epsilon_0}$$

$$g = \frac{F}{m}$$

$$g = \frac{GM}{r^2}$$

$$\text{for point masses, } \Delta E_p = GM_1 M_2 \left(\frac{1}{r_1} - \frac{1}{r_2} \right)$$

$$\text{for point charges, } \Delta E_p = kQ_1 Q_2 \left(\frac{1}{r_1} - \frac{1}{r_2} \right)$$

$$\text{for a straight wire, } F = BIl$$

$$\text{for a moving charge, } F = BQv$$

$$\phi = BA$$

$$\text{induced emf} = \frac{\Delta(N\phi)}{t}$$

$$E = mc^2$$

Temperature and Molecular Kinetic Theory

$$T/\text{K} = \frac{(pV)_T}{(pV)_{tr}} \times 273.16$$

$$pV = \frac{1}{3} Nm \langle c^2 \rangle$$

$$\text{energy of a molecule} = \frac{3}{2} kT$$

Heating and Working

$$\Delta U = Q + W$$

$$Q = mc\Delta\theta$$

$$Q = ml$$

$$P = Fv$$

$$\text{efficiency} = \frac{\text{useful power output}}{\text{power input}}$$

$$\text{work done on gas} = p\Delta V$$

$$\text{work done on a solid} = \frac{1}{2} F\Delta l$$

$$\text{stress} = \frac{F}{A}$$

$$\text{strain} = \frac{\Delta l}{l}$$

$$\text{Young modulus} = \frac{\text{stress}}{\text{strain}}$$

Capacitance and Exponential Change

$$\text{in series, } \frac{1}{C} = \frac{1}{C_1} + \frac{1}{C_2}$$

$$\text{in parallel, } C = C_1 + C_2$$

$$\text{energy stored by capacitor} = \frac{1}{2} QV$$

$$\text{parallel plate capacitance, } C = \frac{\epsilon_0 \epsilon_r A}{d}$$

$$Q = Q_0 e^{-t/RC}$$

$$\text{time constant} = RC$$

$$\text{time to halve} = 0.69 RC$$

$$N = N_0 e^{-\lambda t}$$

$$A = A_0 e^{-\lambda t}$$

$$\text{half-life, } t_{\frac{1}{2}} = \frac{0.69}{\lambda}$$

Momentum and Quantum Phenomena

$$Ft = \Delta(mv)$$

$$E = hf$$

$$hf = \Phi + E_{k(\max)}$$

$$hf = E_2 - E_1$$

$$\lambda = \frac{h}{mv}$$

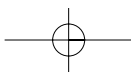

(ii) State how you would use the graph to find the electric potential difference between the points **A** and **B**.

.....
.....

(1 mark)

(b) The permittivity of free space ϵ_0 is $8.9 \times 10^{-12} \text{ F m}^{-1}$.

(i) Calculate the total charge on the Earth.

(2 marks)

(ii) The charge is distributed uniformly over the Earth's surface. Calculate the charge per square metre on the Earth's surface.

(2 marks)

8

TURN OVER FOR THE NEXT QUESTION

Turn over ►

2

Total for this question: 18 marks

A student sets up the system shown in **Figure 2** to determine the acceleration of a cart down a ramp.

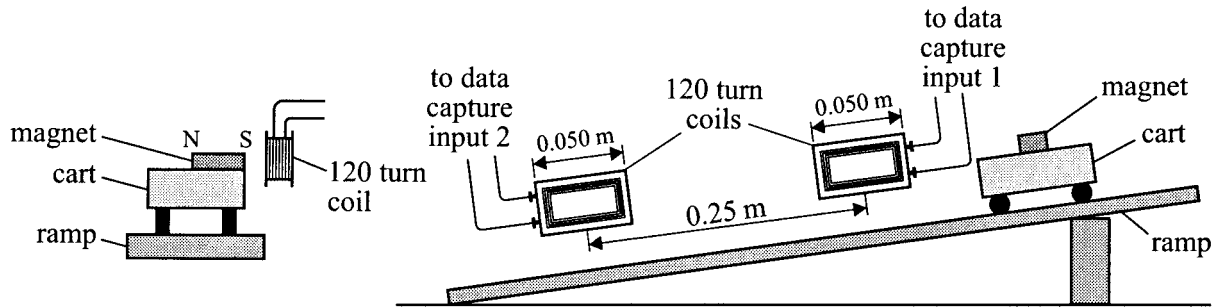

Figure 2

As the cart passes the coils an emf is induced in each coil. The outputs of the coils are monitored using voltage sensors connected to a computer.

Figure 3 shows the computer printouts after one test.

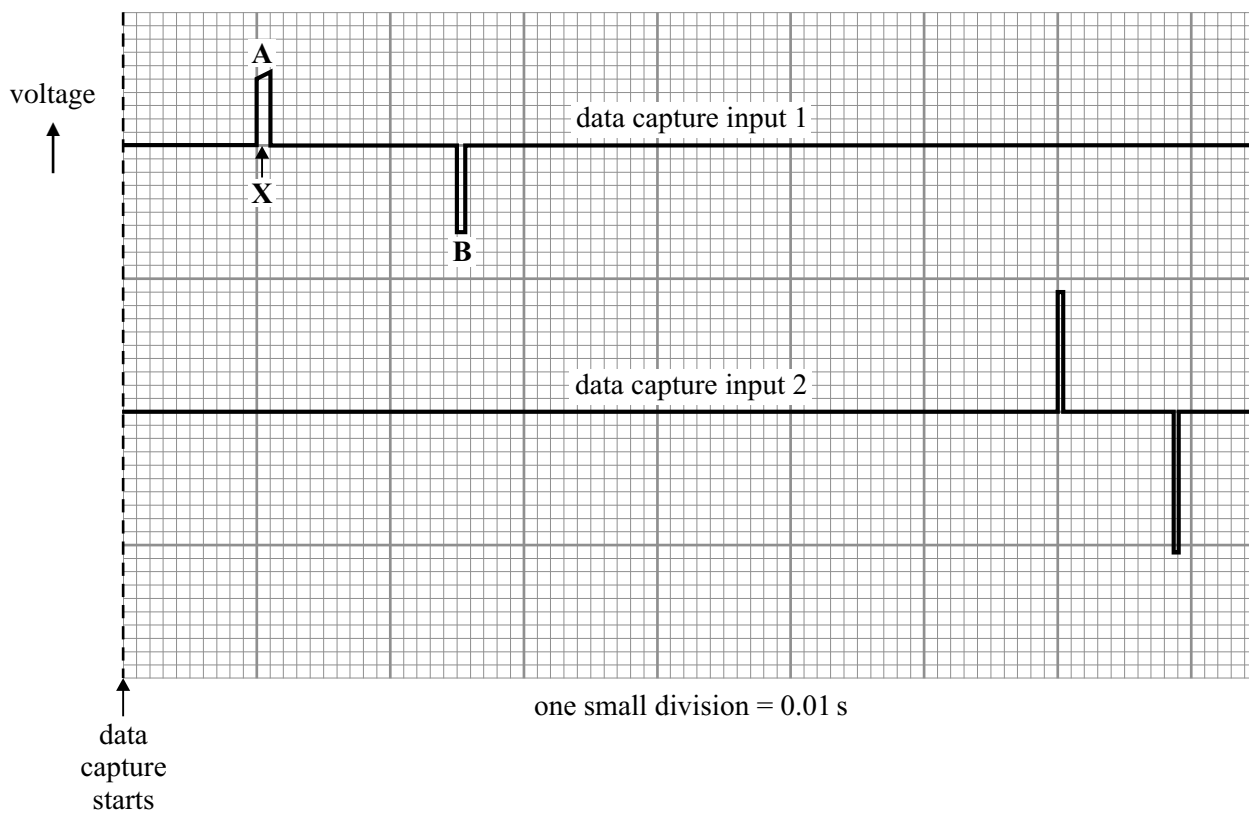
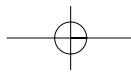

Figure 3



(a) Explain why emfs are induced in the coils.

.....
.....
(1 mark)

(b) (i) Why is the amplitude of pulse **B** larger than pulse **A**?

.....
.....
.....
.....
.....
(2 marks)

(ii) Why is pulse **B** in the opposite direction to pulse **A**?

.....
.....
.....
.....
(2 marks)

(iii) Why is the duration of pulse **B** less than that of pulse **A**?

.....
.....
.....
.....
(2 marks)

(c) (i) The length of a coil is 0.050 m. Show that the mean speed of the cart between **A** and **B** is about 0.3 m s^{-1} .

(2 marks)

QUESTION 2 CONTINUES ON THE NEXT PAGE

Turn over ▶

- (ii) The distance between the centres of the two coils is 0.25 m. Determine a value for the acceleration of the cart between the two coils.

(4 marks)

- (d) **Figure 4** shows a close up view of the magnet when it produces the voltage at the point marked **X** on **Figure 3**. The magnet passes very close to the 120 turn coil so that the magnetic flux density can be considered to be uniform. The magnetic flux density is 0.080 T.

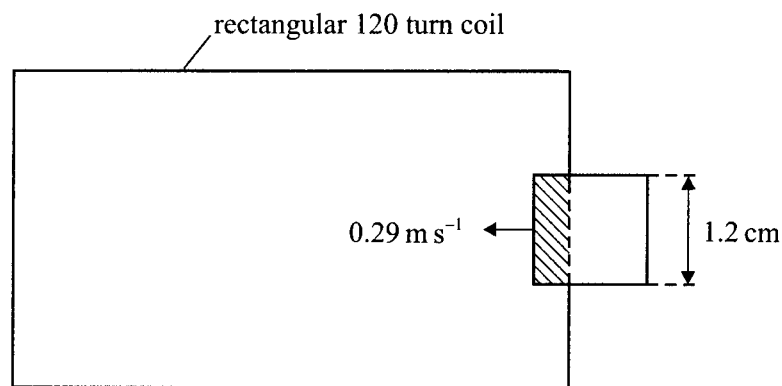

Figure 4

At the instant shown the cart is travelling at 0.29 m s^{-1} . Calculate:

- (i) the rate at which the shaded area on **Figure 4** is changing at this time;

(2 marks)

- (ii) the magnitude of the induced emf at the point **X**.

(3 marks)

18

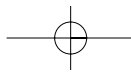

3

Total for this question: 9 marks

Potassium-42 decays with a half-life of 12 hours. When potassium-42 decays it emits β^- particles and gamma rays. One freshly prepared source has an activity of 3.0×10^7 Bq.

- (a) To determine the dose received by a scientist working with the source the number of gamma ray photons incident on each cm^2 of the body has to be known.

One in every five of the decaying nuclei produces a gamma ray photon. A scientist is initially working 1.50 m from the fresh source with no shielding. Show that at this time approximately 21 gamma ray photons per second are incident on each cm^2 of the scientist's body.

(2 marks)

- (b) The scientist returns 6 hours later and works at the same distance from the source.

- (i) Calculate the new number of gamma ray photons incident per second on each cm^2 of the scientist's body.

(3 marks)

- (ii) At what distance from the source could the scientist now work and receive the original dose of 21 photons per second per cm^2 .

(2 marks)

- (c) Explain why it is not necessary to consider the beta particle emission when determining the dose of radiation the scientist receives.

.....

.....

.....

(2 marks)

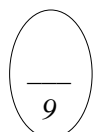

Turn over ►

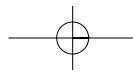

4

Total for this question: 31 marks

In this question you will consider aspects involved in the communication of signals between two points on the Earth's surface such as those shown in **Figure 5**. Information may be sent through a cable that conducts electrical signals or using radio waves transmitted through space using a satellite.

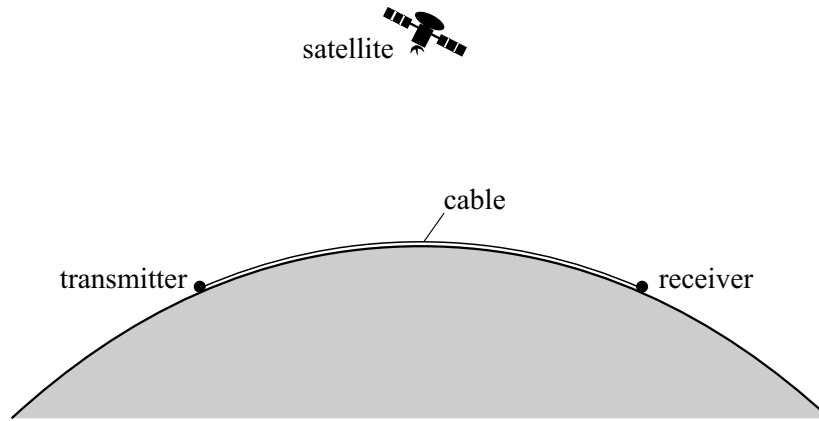

Figure 5

- (a) (i) Suggest **two** factors that need to be taken into account when considering the economic advantages and disadvantages of the two methods of transmission.

.....

.....

.....

.....

(2 marks)

- (ii) Suggest **two** environmental or safety factors that need to be taken into account when comparing the two methods of transmission.

.....

.....

.....

.....

(2 marks)

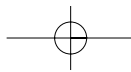

LEAVE
MARGIN
BLANK

(iii) A satellite is necessary for the transmission of very high frequency radio signals, for example, using microwaves. However, a satellite or cable is not necessary for the transmission of signals in the long wave band such as those of wavelength 1500 m. Explain why.

.....

.....

.....

.....

.....

.....

.....

.....

(4 marks)

QUESTION 4 CONTINUES ON THE NEXT PAGE

Turn over ►

- (b) **Figure 6** shows a system in which an unmodulated audio frequency signal is transmitted from the transmitter to the receiver through a cable. The cable consists of two strands of insulated copper wire.

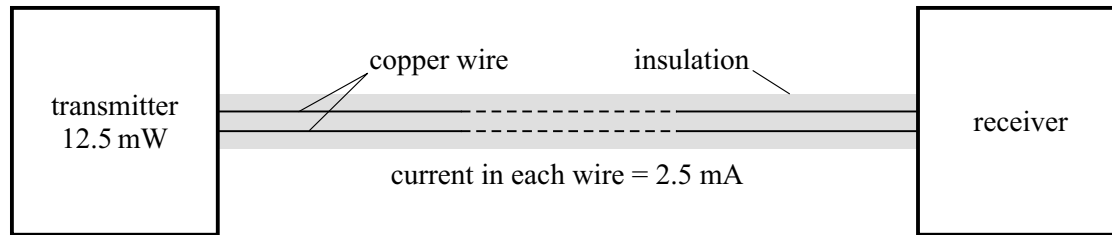

Figure 6

The power output of the transmitter is 12.5 mW and the corresponding current **in each wire** is then 2.5 mA. Power is lost to the surroundings due to the rise in temperature produced by this current. For the transmitted signal to be detected the power input to the receiver must be at least 1.5 mW.

Each wire has a cross-sectional area $6.2 \times 10^{-8} \text{ m}^2$. The resistivity of copper is $1.7 \times 10^{-8} \Omega \text{ m}$.

- (i) Calculate the resistance of 1.0 m of the copper wire used in the cable.

(2 marks)

- (ii) Calculate the maximum distance between the transmitter and receiver at which the transmission can be detected successfully.

(3 marks)

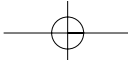

(iii) In an attempt to improve the distance over which communication of this signal is possible a designer connects transformers as shown in **Figure 7**. This system is similar to the one used to transmit electrical energy from a power station to a consumer.

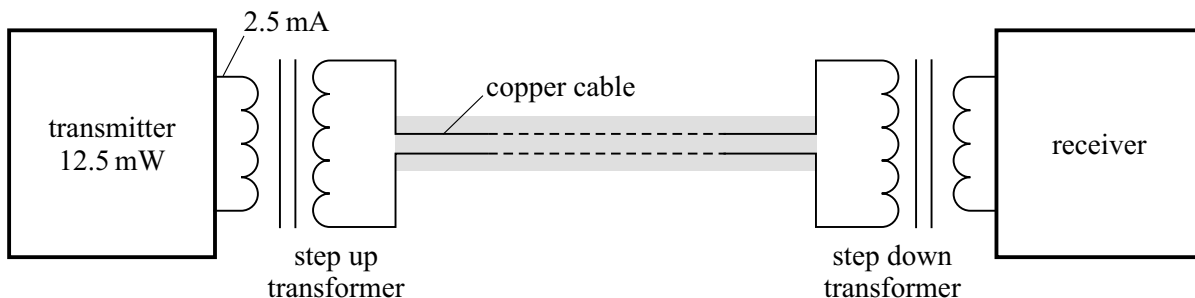

Figure 7

The ratio of the number of turns on the primary coil to the number of turns on the secondary coil is 1:4 for the step up transformer and 4:1 for the step down transformer.

Explain whether this modification could have the desired effect.

In your answer you should:

- consider how the modification affects the power loss in the copper cables;
- discuss other factors in the system that may have an effect on the maximum distance for which communication is successful.

Two of the 7 marks in this question are available for the quality of your written communication.

.....

.....

.....

.....

.....

.....

.....

.....

.....

.....

.....

.....

.....

.....

.....

(7 marks)

QUESTION 4 CONTINUES ON THE NEXT PAGE

Turn over ▶

(c) The satellites used in communication are in an orbit above the equator with a period of one day.

(i) Explain why such satellites are placed in an orbit with a period of one day.

.....
.....
.....

(2 marks)

(ii) Show that the radius of the orbit of such a satellite is 42 000 km.

$$\begin{aligned} \text{universal gravitational constant } G &= 6.7 \times 10^{-11} \text{ N m}^2 \text{ kg}^{-2} \\ \text{mass of the Earth} &= 6.0 \times 10^{24} \text{ kg} \end{aligned}$$

(4 marks)

(iii) The radius of the Earth is 6400 km. The satellite has a mass of 2500 kg. Calculate the change in gravitational potential energy of the satellite when it is lifted into the orbit of radius 42 000 km.

(3 marks)

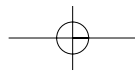

LEAVE
MARGIN
BLANK

(iv) Estimate the minimum delay time (i.e. the time between transmission and reception) of a signal transmitted between two points on the Earth's surface using a satellite.

The speed of the electromagnetic waves through free space is $3.0 \times 10^8 \text{ m s}^{-1}$.

(2 marks)

31

*The passage for answering questions 5, 6, 7, 8 and 9 is printed on pages 17 and 18.
Detach pages 17 and 18 and read the passage before answering the questions.*

5

Total for this question: 6 marks

Explain what is meant by *gravitational collapse* (lines 1–2) and how this raises the temperature of the hydrogen gas.

Two of the 6 marks in this question are available for the quality of your written communication.

.....

.....

.....

.....

.....

.....

.....

.....

.....

.....

.....

.....

.....

.....

.....

.....

.....

.....

.....

(6 marks)

6

Turn over ►

6

Total for this question: 5 marks

- (a) Assuming the plasma behaves as an ideal gas, show that the data in the passage suggests a pressure of about 3×10^{14} Pa inside the Sun.

Universal gas constant $R = 8.3 \text{ J mol}^{-1} \text{ K}^{-1}$
 Avogadro constant $N_A = 6.0 \times 10^{23} \text{ mol}^{-1}$

(3 marks)

- (b) Suggest why this pressure does not result in the Sun exploding.

.....

(2 marks)

5

7

Total for this question: 6 marks

- (a) In a Type 1 reaction it is essential for another particle to be formed as well as the deuteron and positron. State the name of this particle and explain why it must be present in the products.

.....

(2 marks)

- (b) Write down the nuclear equation representing:

- (i) a Type 3 reaction (line 13);

.....

(2 marks)

- (ii) the annihilation of a positron with an electron.

.....

(2 marks)

6

The passage printed on pages 17 and 18 is for answering questions 5, 6, 7, 8 and 9.
Detach pages 17 and 18 and read the passage **before** answering questions 5, 6, 7, 8 and 9.

Thermonuclear energy

Stars are initially formed by gravitational attraction between hydrogen atoms. The gravitational collapse raises the temperature of the gas so that eventually the atoms ionise forming a plasma which consists only of nuclei and free electrons. When the temperature is high enough the power is then produced by nuclear fusion.

The inside of the Sun is thought to be at a temperature of at least 1×10^8 K and it is radiating energy at a rate of 3.9×10^{26} W. The high temperature and the large number of atoms per cubic metre (about 2×10^{29}) produces a very high pressure inside the plasma. It is thought that the power is generated by a cycle of reactions called a *hydrogen cycle*. In this cycle there are 3 types of reaction, illustrated in **Figure 8**.

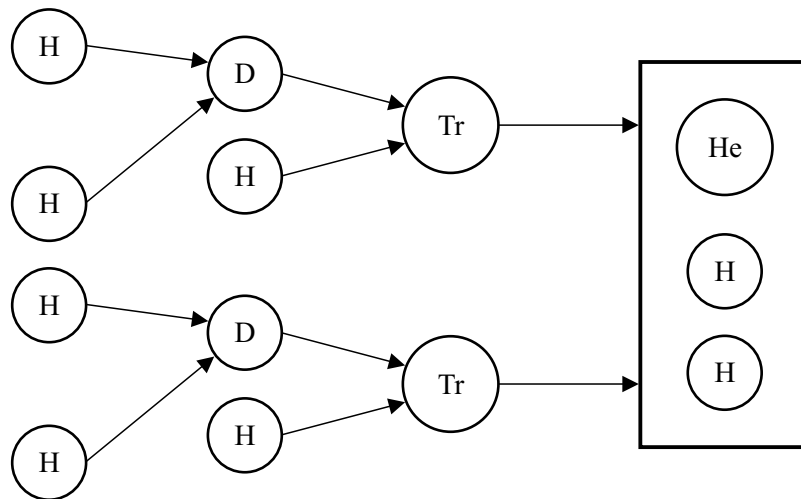

Figure 8

- Type 1 Two hydrogen nuclei (${}^1_1\text{H}$) combine to form a deuteron (${}^2_1\text{H}$) with the emission of a positron, making available 6.7×10^{-14} J of energy. 10
- Type 2 A deuteron combines with a hydrogen nucleus to produce a tritium nucleus (${}^3_1\text{H}$) and 8.8×10^{-13} J of energy.
- Type 3 Two tritium nuclei combine to form helium and two hydrogen nuclei and 2.1×10^{-12} J of energy.

In each cycle two Type 1 and two Type 2 reactions occur. The net effect is the combination of four 15 hydrogen nuclei to produce a helium nucleus and two positrons. Each positron is annihilated when it combines with an electron present in the plasma. This process releases more energy in the form of two gamma ray photons each of energy 1.6×10^{-13} J.

Scientists are attempting to copy the thermonuclear process of the Sun in a fusion reactor. The most likely 20 successful reaction is the interaction of a deuteron with a tritium nucleus. This is a reaction that produces a helium nucleus and a neutron and releases 2.9×10^{-12} J of energy. The raw materials of fusion reactors are more readily available than those used in fission reactors. Deuterons are the nuclei of deuterium. Deuterium is readily available since 0.015% of hydrogen obtained from water is deuterium. The tritium is produced using lithium which is also fairly abundant.

Turn over ►

In order for a deuteron and tritium nucleus to combine they need to touch. To do this they need to have 25 about 7×10^{-14} J of kinetic energy which is sufficient to overcome the coulomb repulsion of the charges on the nuclei. This means that they have to be as close together as the sum of their radii, 1.5×10^{-15} m and 1.7×10^{-15} m respectively. It is therefore necessary for the sum of their kinetic energies to be equal to the electrical potential energy of the nuclei at this separation. This can only occur when the plasma is at a very 30 high temperature.

In the proposed system for a practical reactor the plasma will be contained by magnetic fields in a doughnut shaped channel, called a torus. Other coils will induce high currents in the plasma. These currents will produce the high temperature necessary to initiate the fusion process. The reaction should then become self-sustaining. A lithium blanket will be used to absorb energy liberated by the plasma and the lithium will then be transferred to the heat exchanger. This in turn will heat water to produce the steam used in the 35 production of electricity. The whole apparatus will have to be shielded by a material to absorb neutrons. The shielding material will become radioactive when the reactor operates. The solid radioactive shielding is less dangerous than the radioactive by-products of a fission reactor because these by-products can be leaked into the environment.

8**Total for this question: 6 marks**

- (a) (i) Calculate the total energy liberated in one hydrogen cycle.

(3 marks)

- (ii) Determine the mass change during one complete hydrogen cycle.

$$\text{speed of electromagnetic radiation} = 3.0 \times 10^8 \text{ m s}^{-1}$$

(2 marks)

- (b) Calculate the number of helium nuclei being produced in the Sun each second.

(1 mark)

6

9**Total for this question: 11 marks**

- (a) For this question you will need the following additional data.

$$\begin{aligned} \text{The charge on a proton} &= +1.6 \times 10^{-19} \text{ C.} \\ \text{The permittivity of free space} &= 8.9 \times 10^{-12} \text{ F m}^{-1}. \\ \text{The Boltzmann constant} &= 1.4 \times 10^{-23} \text{ J K}^{-1}. \end{aligned}$$

- (i) Show that $7 \times 10^{-14} \text{ J}$ is sufficient for a deuterium and tritium nucleus to touch and undergo fusion.

(3 marks)

Turn over ►

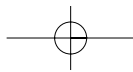

(ii) Calculate the temperature at which the mean kinetic energy of the nuclei is sufficient for fusion to take place.

(2 marks)

(iii) Explain why, in practice, fusion may take place at a temperature well below that you have calculated in part (ii).

.....
.....
.....
.....

(2 marks)

(b) Explain what is meant by the reaction being *self-sustaining* (line 34).

.....
.....
.....
.....

(2 marks)

(c) Give two reasons mentioned in the article that make the search for a practical fusion reactor desirable.

.....
.....
.....
.....

(2 marks)

11

END OF QUESTIONS